



Montageanleitung

Installation instructions

Instructions de montage

Montagehandleiding

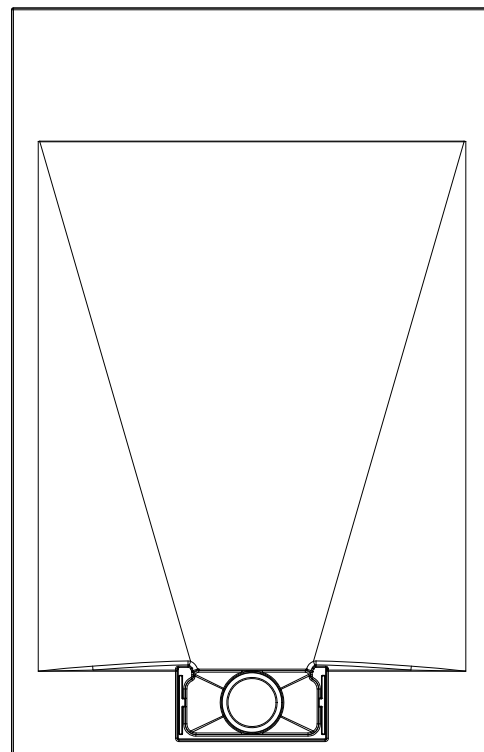
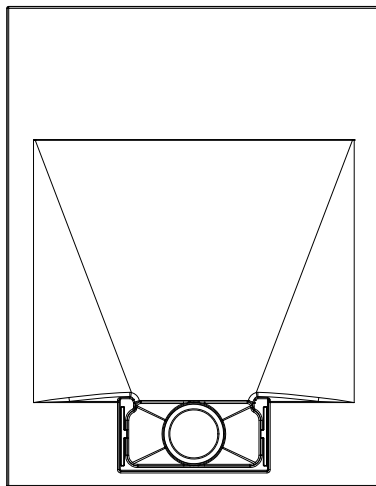

Sicherheitshinweise, Safty instructions, Consignes de sécurité, Veiligheidsaanwijzingen

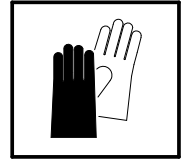
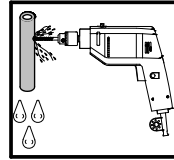
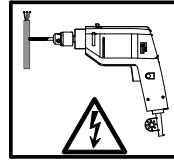
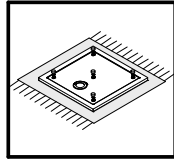
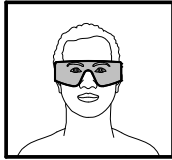

i Benötigtes Werkzeug, Tool needed, outillage nécessaire, Benodigd gereedschap

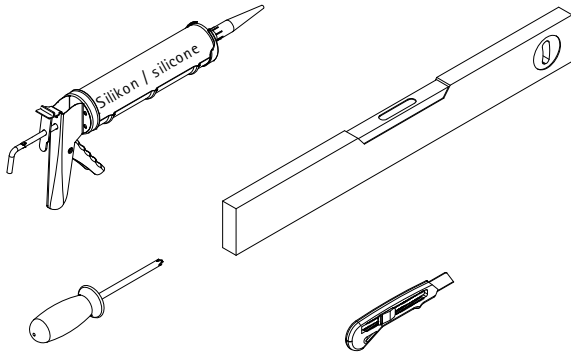

* optional, en option, optioneel

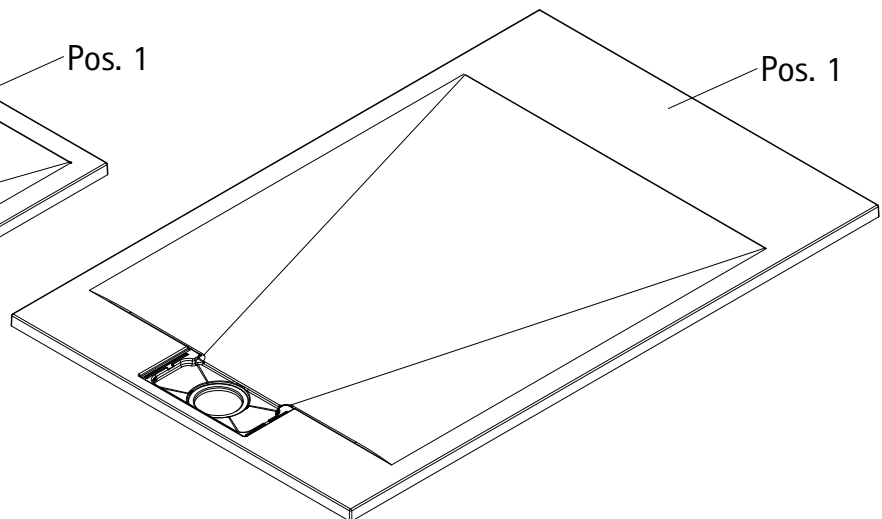
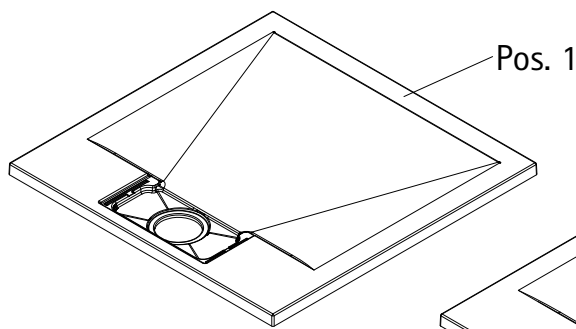
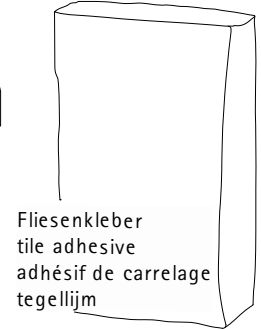
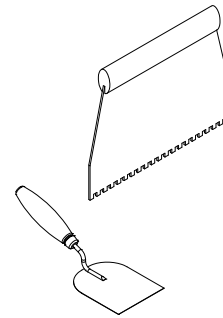

800 x 800 x 32 mm
900 x 900 x 32 mm

700 x 1500 x 32 mm
700 x 1600 x 32 mm
700 x 1700 x 32 mm
800 x 900 x 32 mm
800 x 1000 x 32 mm
800 x 1200 x 32 mm
800 x 1400 x 32 mm
800 x 1600 x 32 mm
900 x 1000 x 32 mm
900 x 1200 x 32 mm
900 x 1400 x 32 mm
900 x 1600 x 32 mm

Dichtset Duschwanne
Sealing set shower tray
Kit d'étanchéité receveur
Dichtingsset douchebak

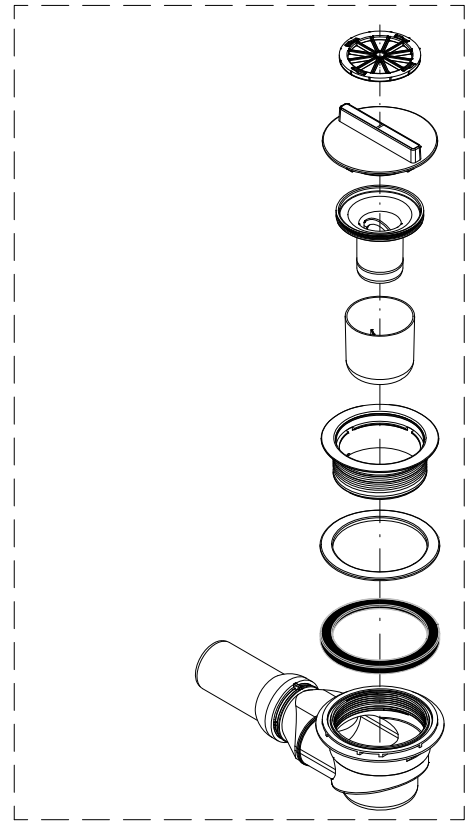
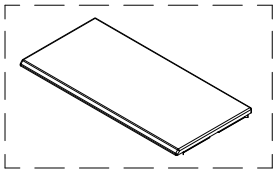

Optional lieferbar, optionally available, disponible en option, optioneel leverbaar

1

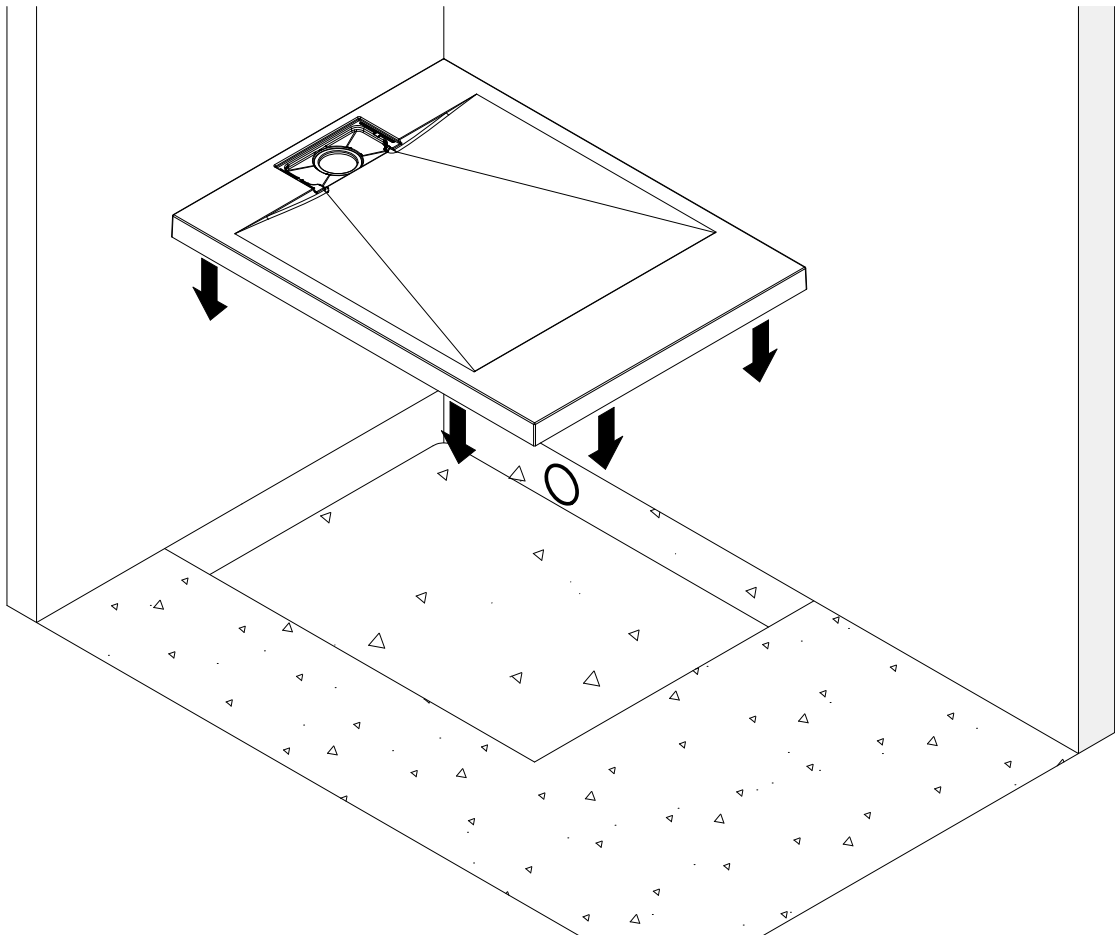

2

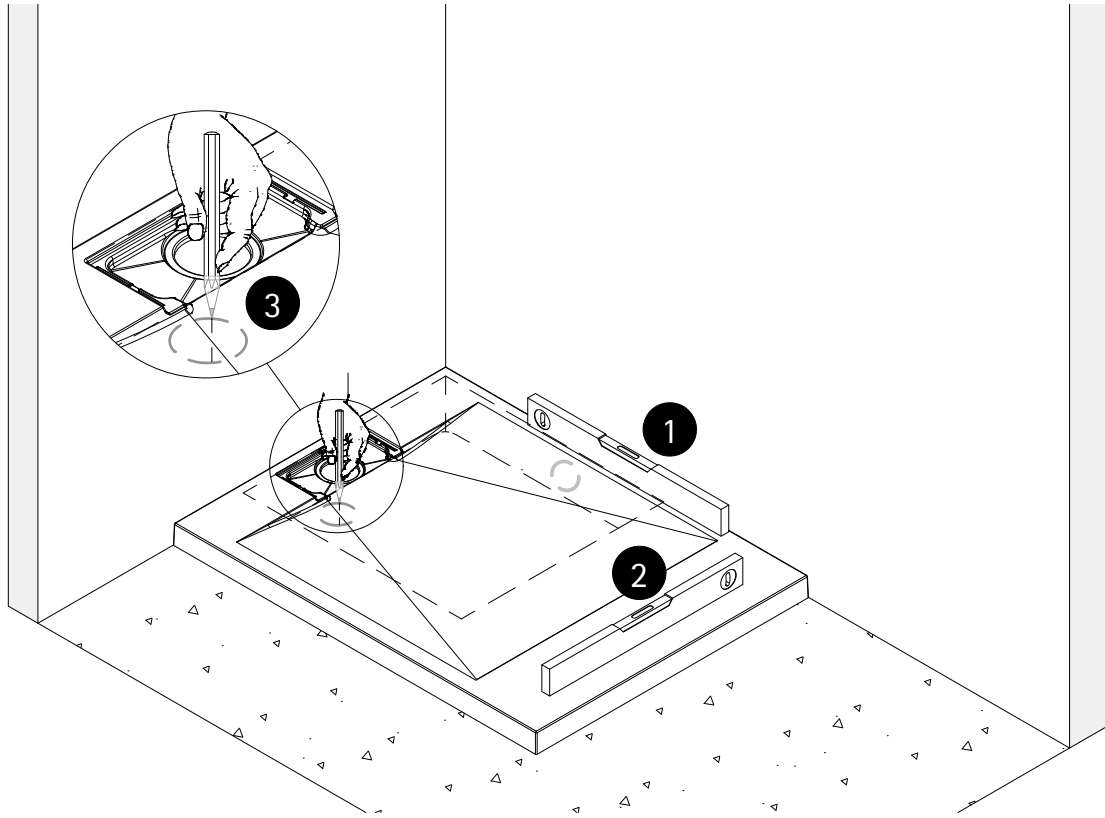

3

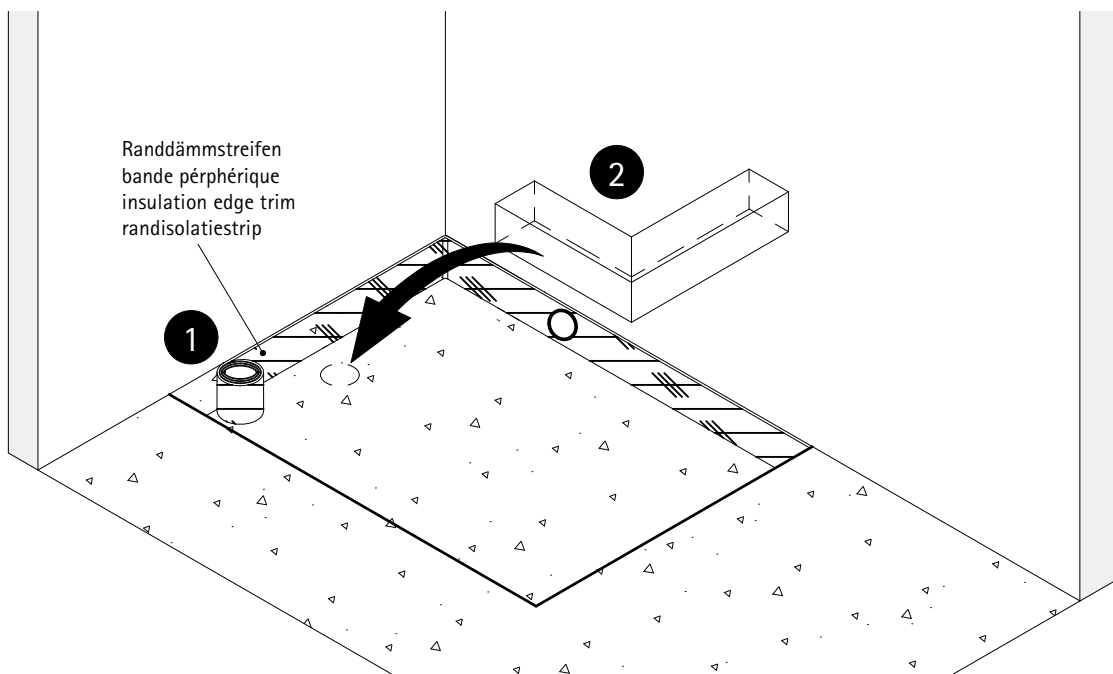

2

- de** Schalungselement (nicht im Lieferumfang enthalten) im Verlauf des Ablaufes einsetzen.
Randdämmstreifen (nicht im Lieferumfang enthalten) an allen Seitenwänden der Vertiefung fixieren.
- en** Use the formwork element (not included) in the course of the process.
Install edge insulation strips (not included in the scope of delivery) on all side walls of the recess.
- fr** Installer L'élément de coffrage (non inclus dans la livraison) au cours du processus.
Fixer les bandes périphériques (non inclus dans la livraison) sur toutes les parois latérales de la cavité.
- nl** Schaalelement (niet bij levering inbegrepen) aan alle zijwanden van de verlaging fixeren.

4

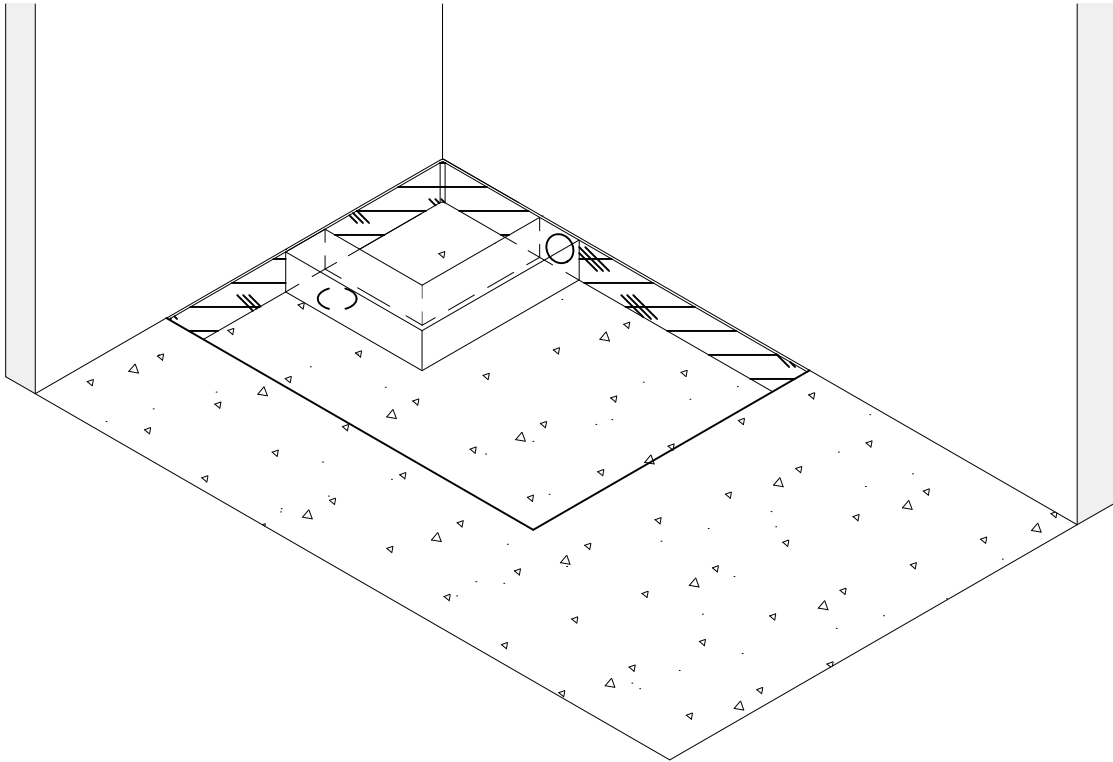

5

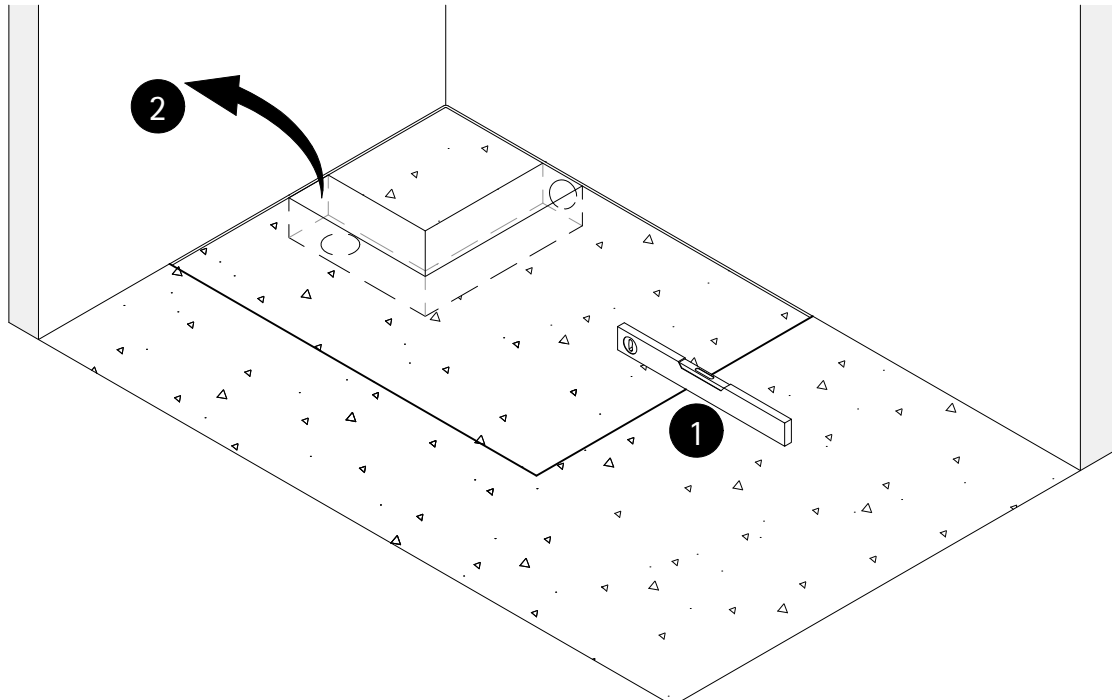

1

de Estrich ebenerdig anarbeiten, bei bodengleichem Einbau der Duschwanne bitte die Estrichhöhe und Abdichtungsmaßnahmen anpassen.

en Prepare screed at ground level; in case of floor-level installation of the shower tray, please adjust screed height and sealing measures.

fr Préparez la chape au niveau du sol, en cas de montage de plain-pied du receveur de douche, veuillez adapter la hauteur de la chape et les mesures d'étanchéité.

nl De dekvloer op de begane grond voorbereiden; bij montage van de douchebak op vloerniveau, de hoogte van de dekvloer en de afdichtingsmaatregelen aanpassen.

6

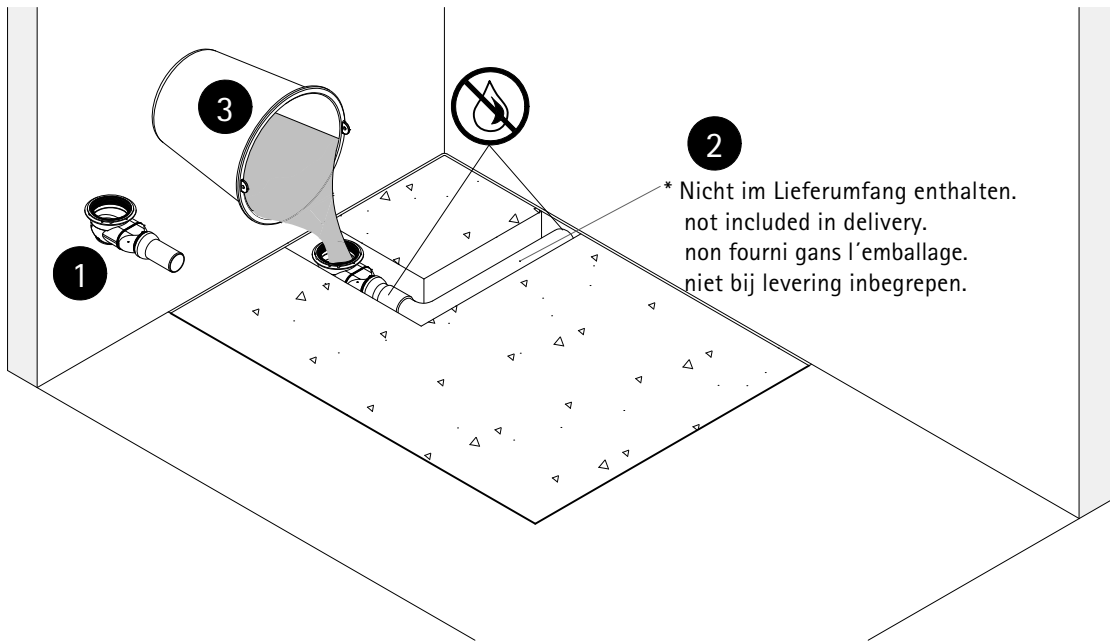

Optional lieferbar, optionally available, disponible en option, optioneel leverbaar



- de Ablauf fachgerecht anbringen und mit Wasser einen Dichtigkeitstest machen.
- en Install the waste professionally and do a leak test with water.
- fr Installer la bonde appropriée et faites un test d'étanchéité avec de l'eau.
- nl Afvoer vakkundig plaatsen en met water testen op dichtheid.

7

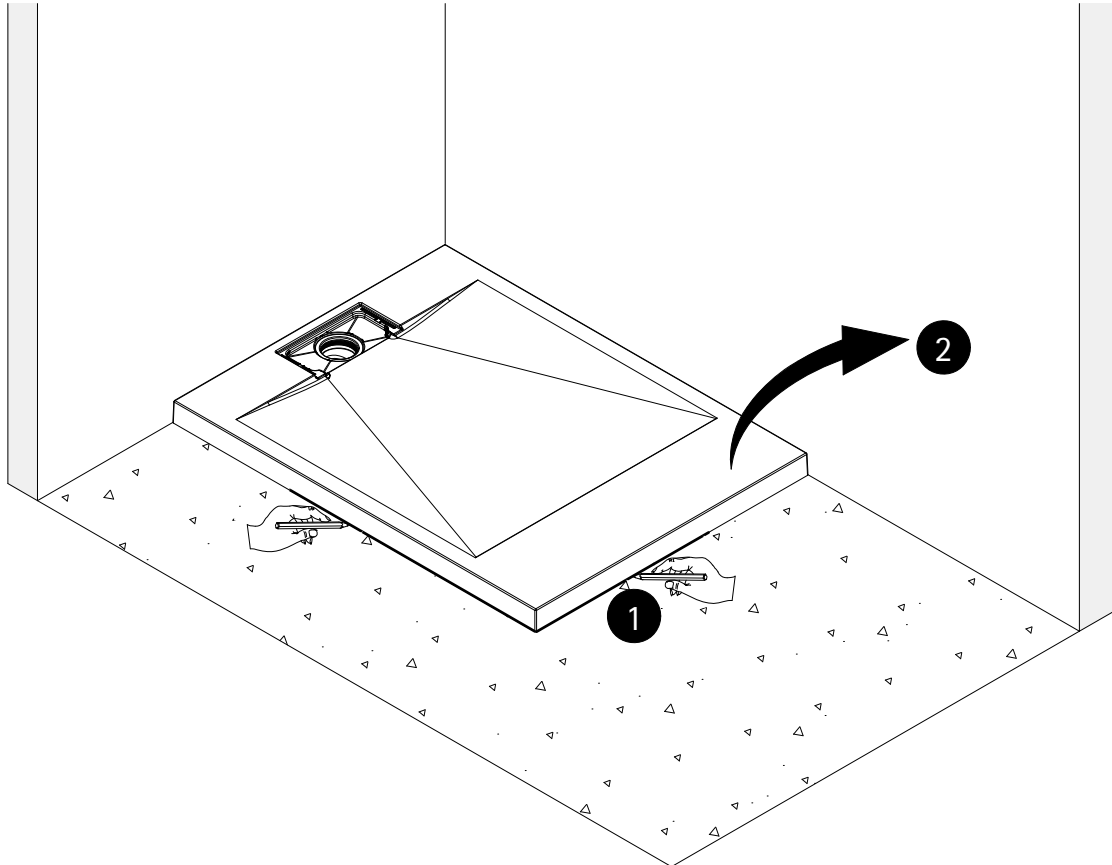

8

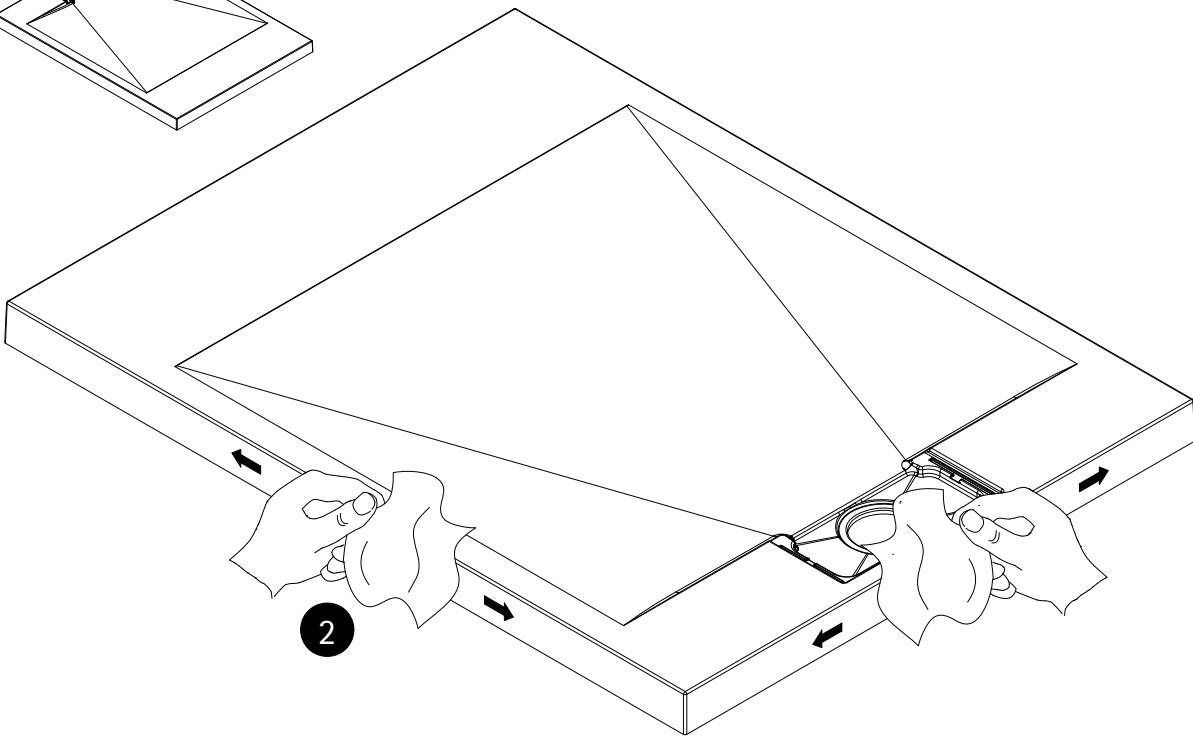
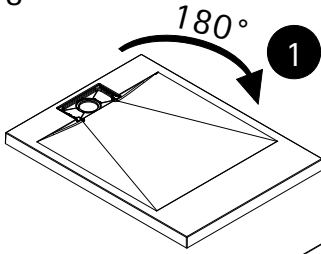

9

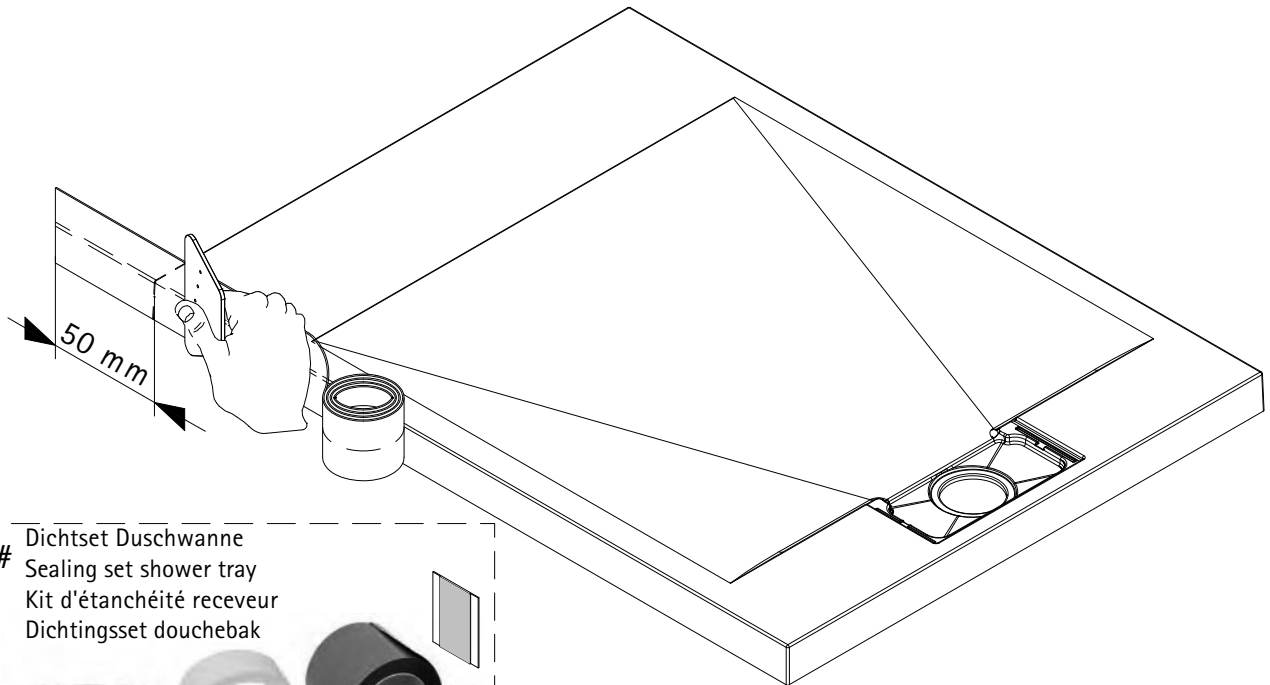

Dichtset Duschwanne
Sealing set shower tray
Kit d'étanchéité receveur
Dichtingsset douchebak

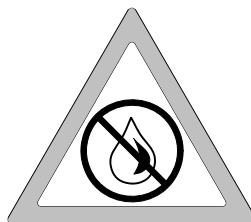

Optional lieferbar, optionally available, disponible en option, optioneel leverbaar

10

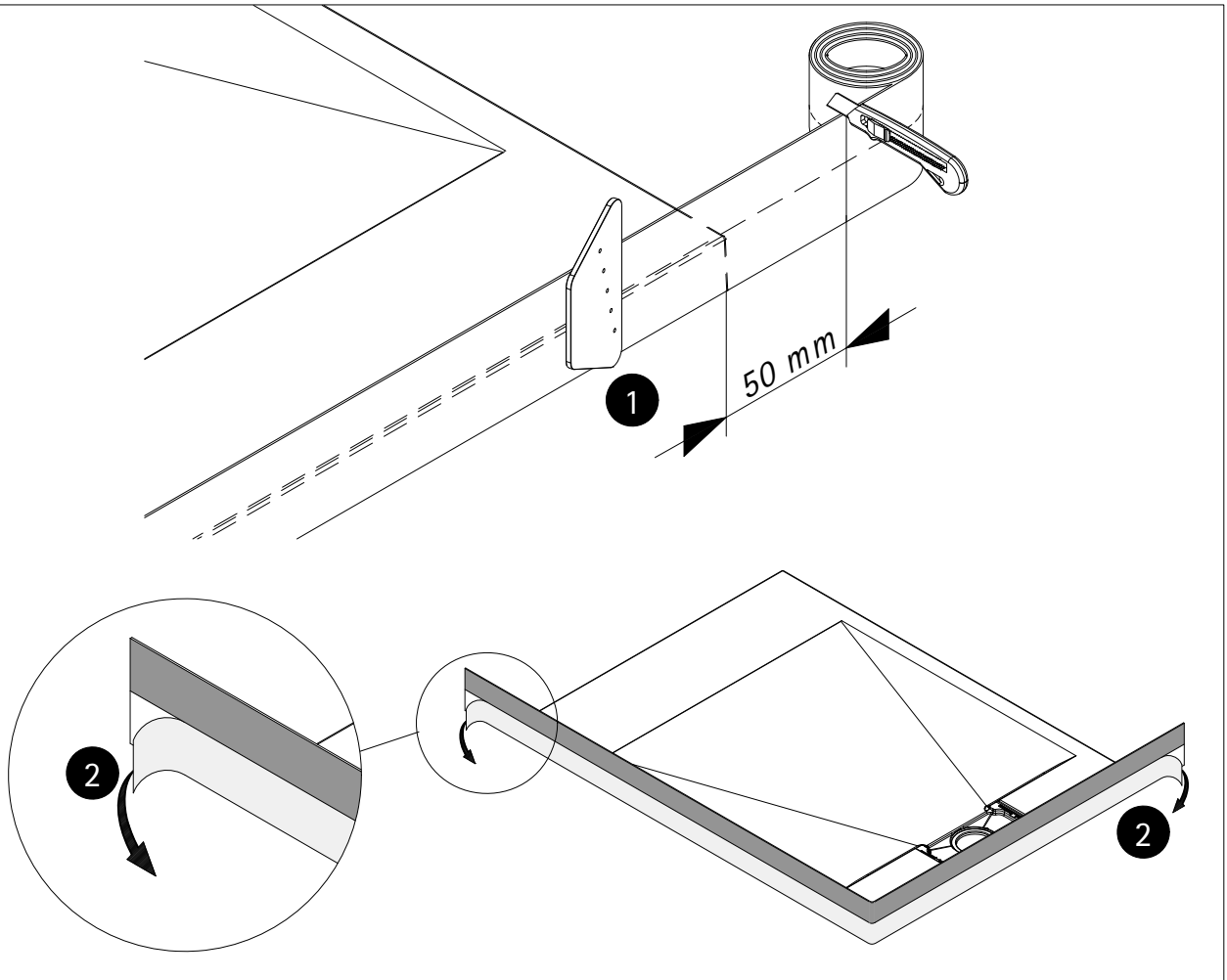

11

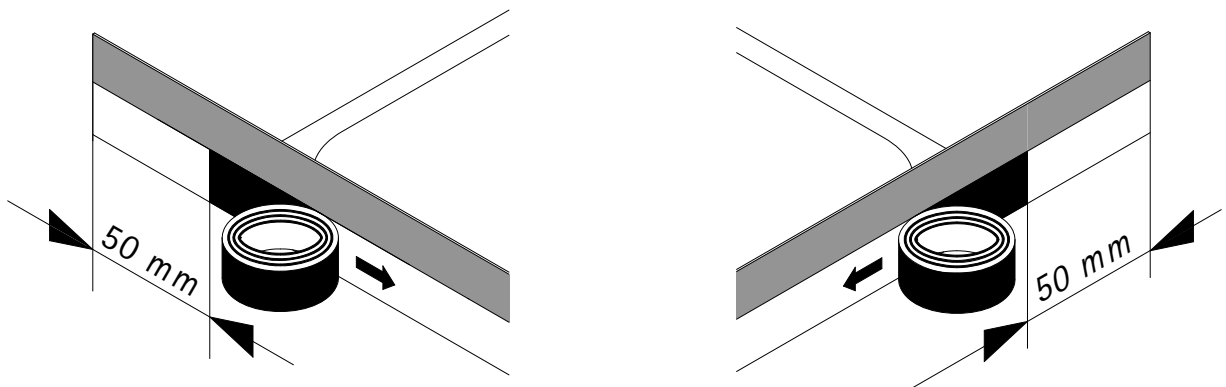

12

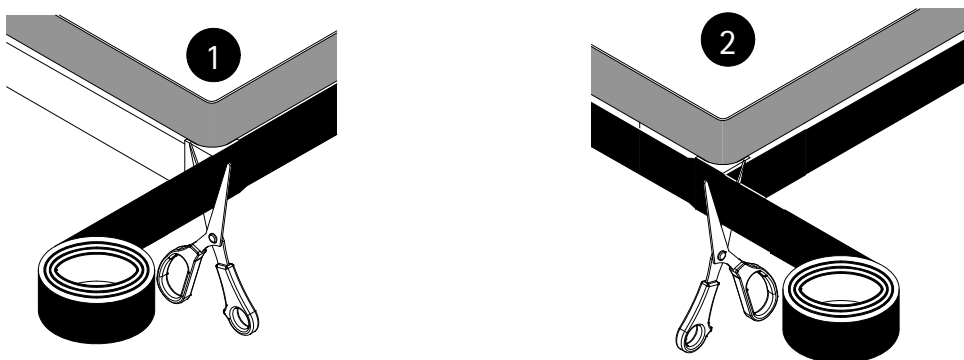

13

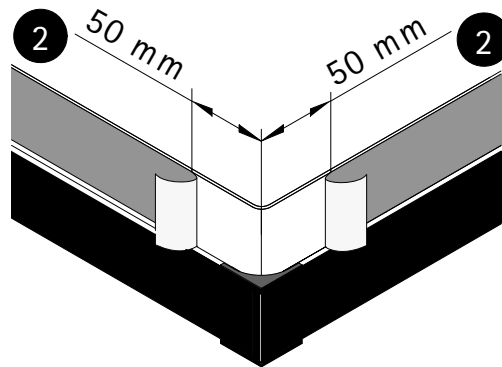
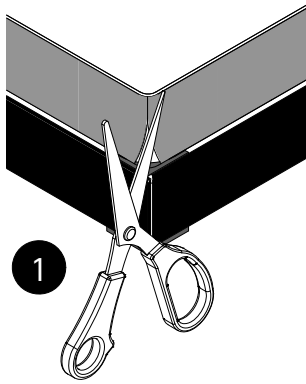

14

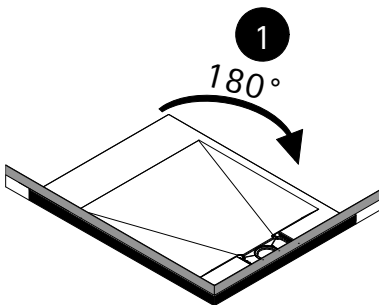

- de Dehnen des Wannendichtbandes in Ecke.
- en Stretch the shower tray sealing tape in the corner.
- fr Étirez la bande d'étanchéité du receveur dans le coin.
- nl De Afdichtingband in de hoek uitrekken.

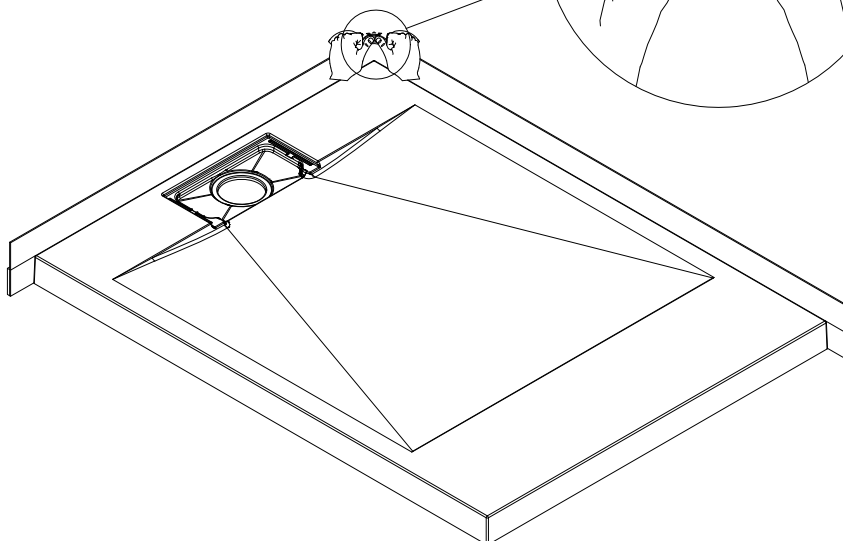
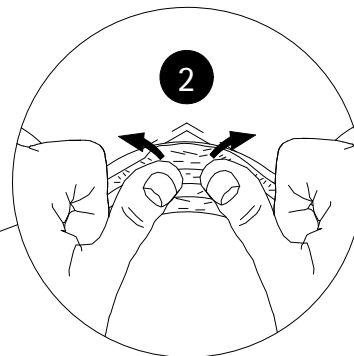

15 # Pos. 3.2

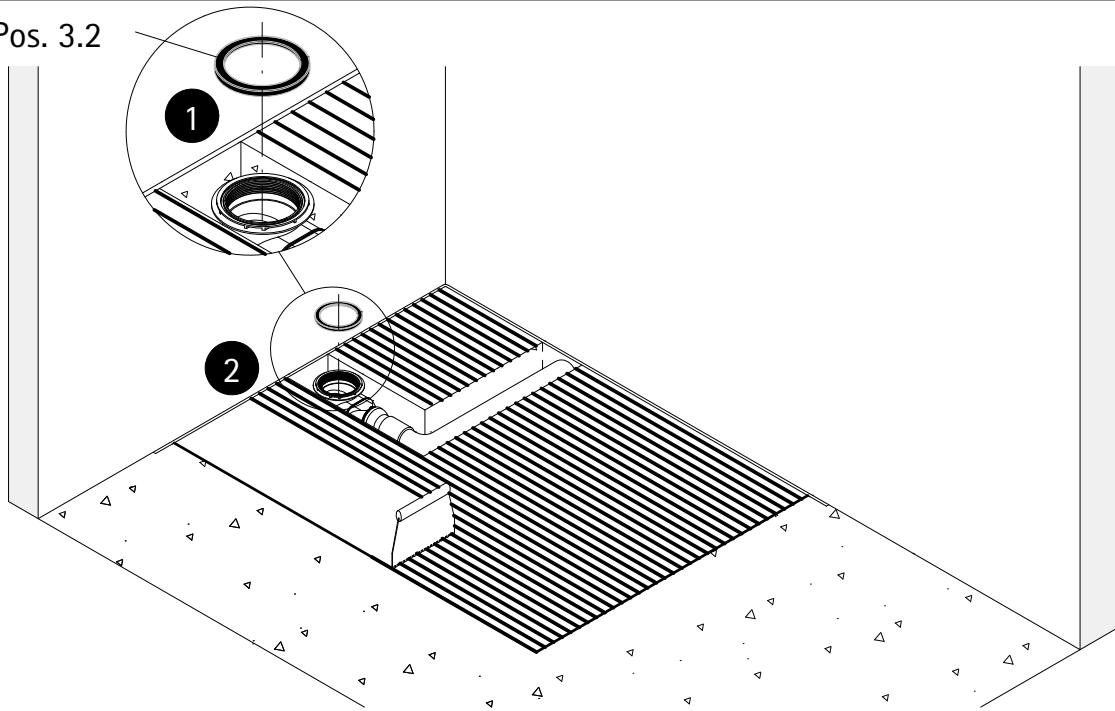

Optional lieferbar, optionally available, disponible en option, optioneel leverbaar

2

- de Fliesenkleber (nicht im Lieferumfang enthalten) mit einem Zahnpachtel auf die angezeichnete Fläche auftragen.
- en Apply the tile adhesive (not included in the scope of delivery) on the marked surface with the notched trowel.
- fr Appliquez la colle à carrelage (non fournie) sur la surface dessinée à l'aide du berthelet.
- nl Breng de tegellijm (niet bij de levering inbegrepen) met de getande spaan aan op het gemarkeerde oppervlak.

16

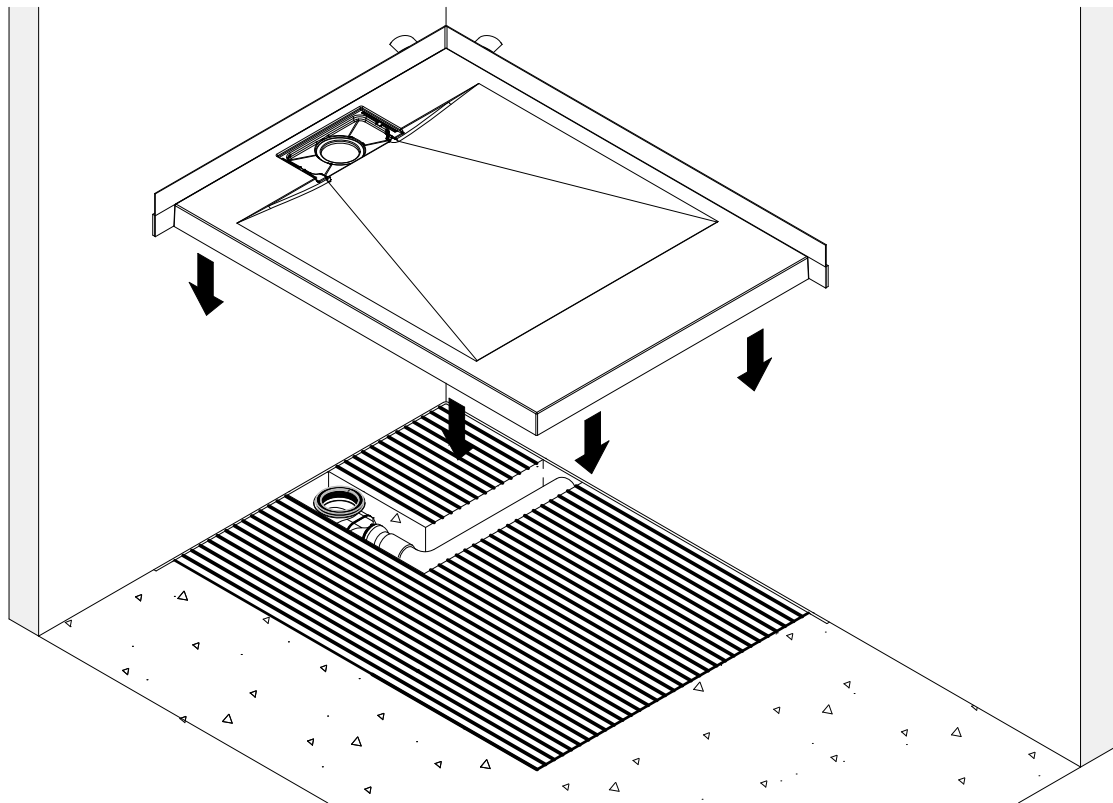

- de Die Duschwanne positionieren und ausrichten.
- en Position and align the shower tray.
- fr Positionnez et alignez le receveur de douche.
- nl Plaats de douchebak en lijn hem uit.

17 # Optional lieferbar, optionally available, disponible en option, optioneel leverbaar

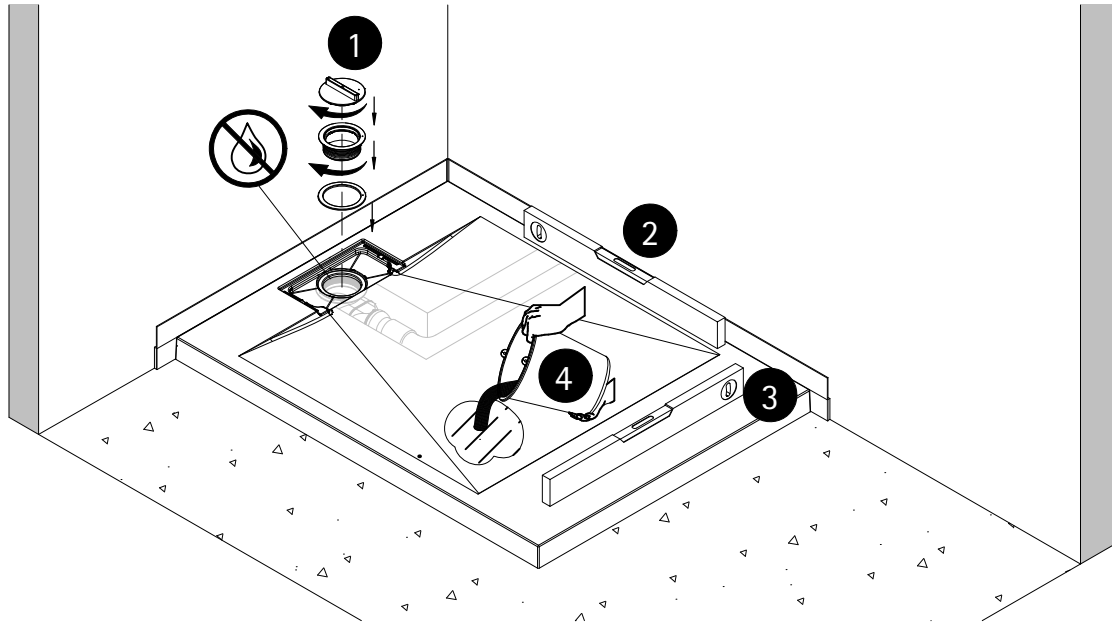

4

- de Überprüfen Sie das Ablaufverhalten der Duschwanne.
- en Check the drainage performance of the shower tray.
- fr Vérifiez l'évacuation de l'eau de receveur de douche.
- nl Controleer het afvoergedrag van de douchebak.

18

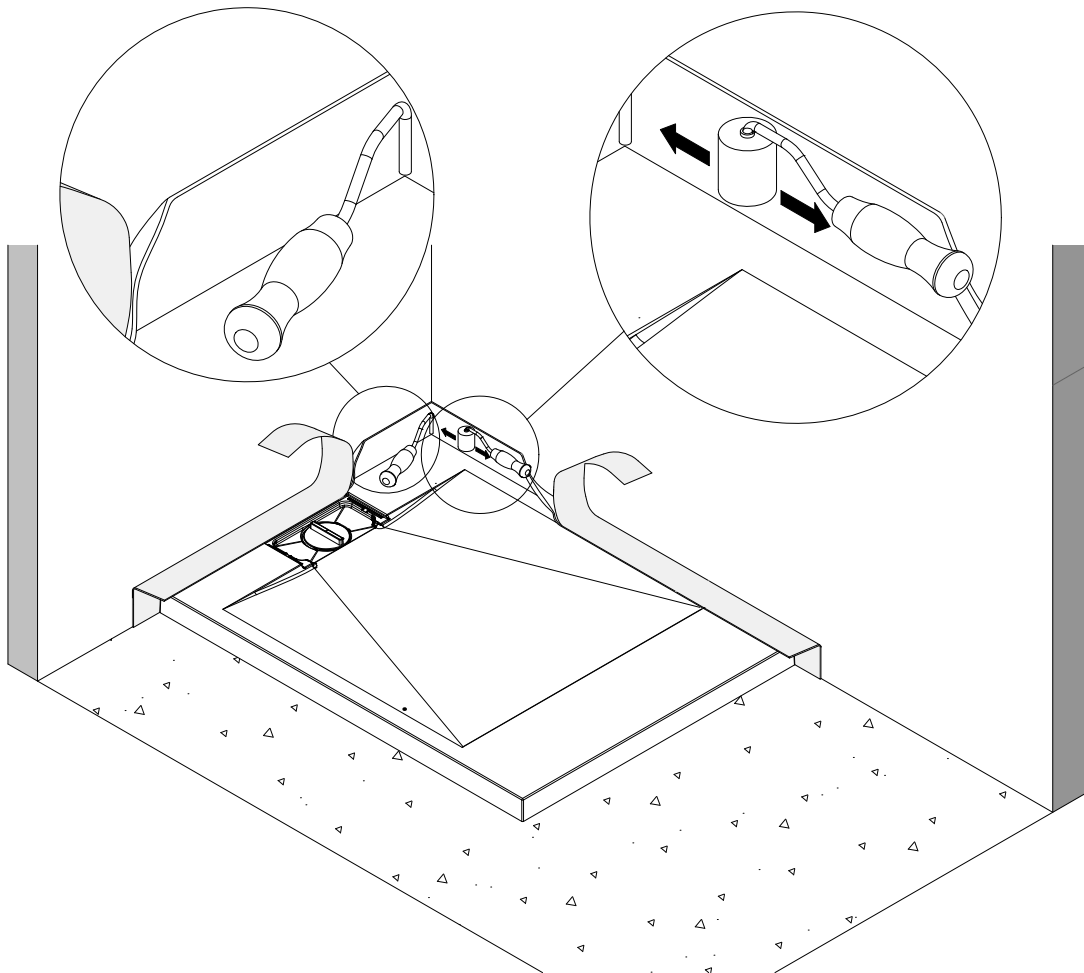

19

- Verbundabdichtung
- Composite sealing
- Étanchéité composite
- Composiet waterdicht maken

* Nicht im Lieferumfang enthalten.
not included in delivery.
non fourni gans l'emballage.
niet bij levering inbegrepen.

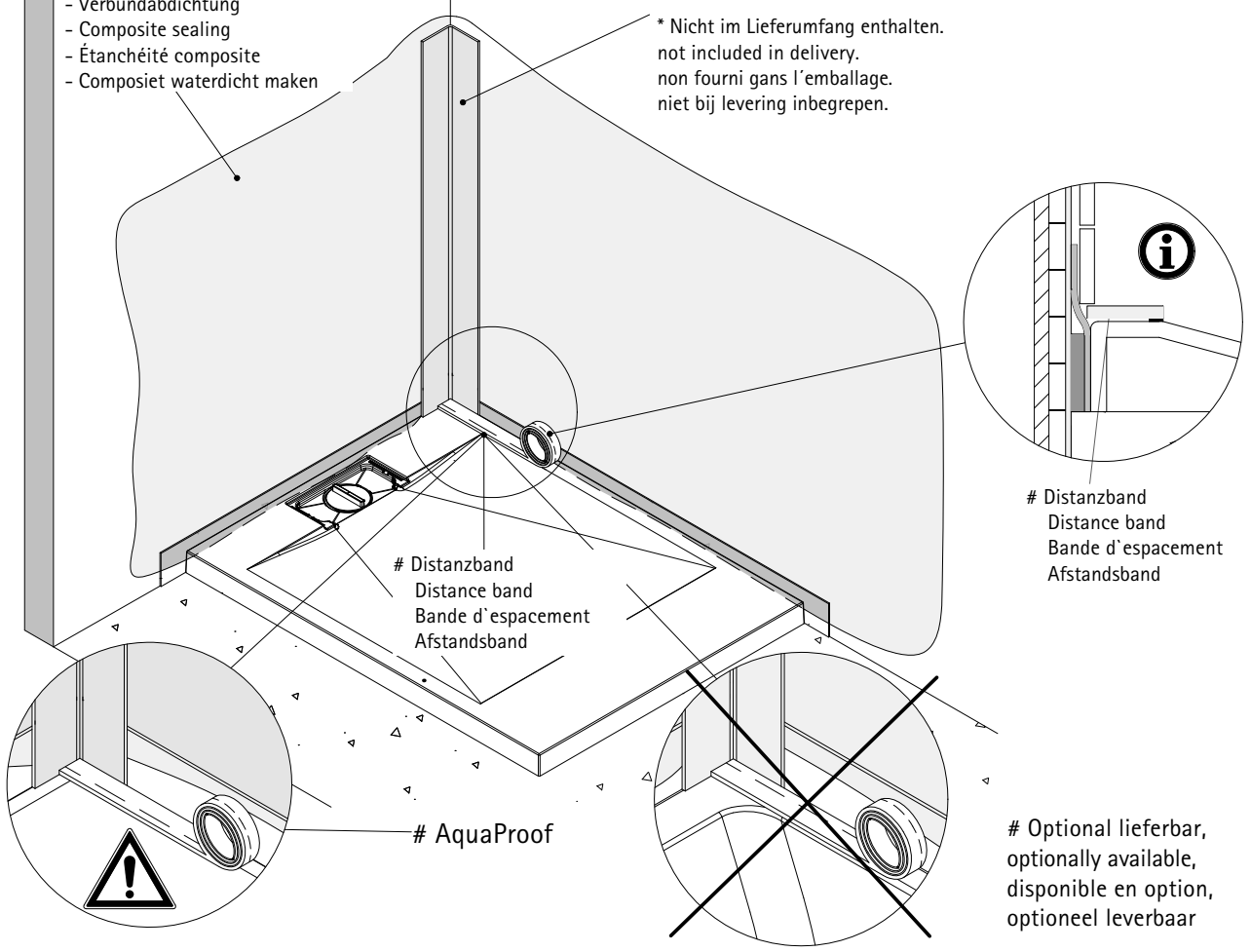

20

Distanzband
Distance band
Bande d'espace
Afstandsband

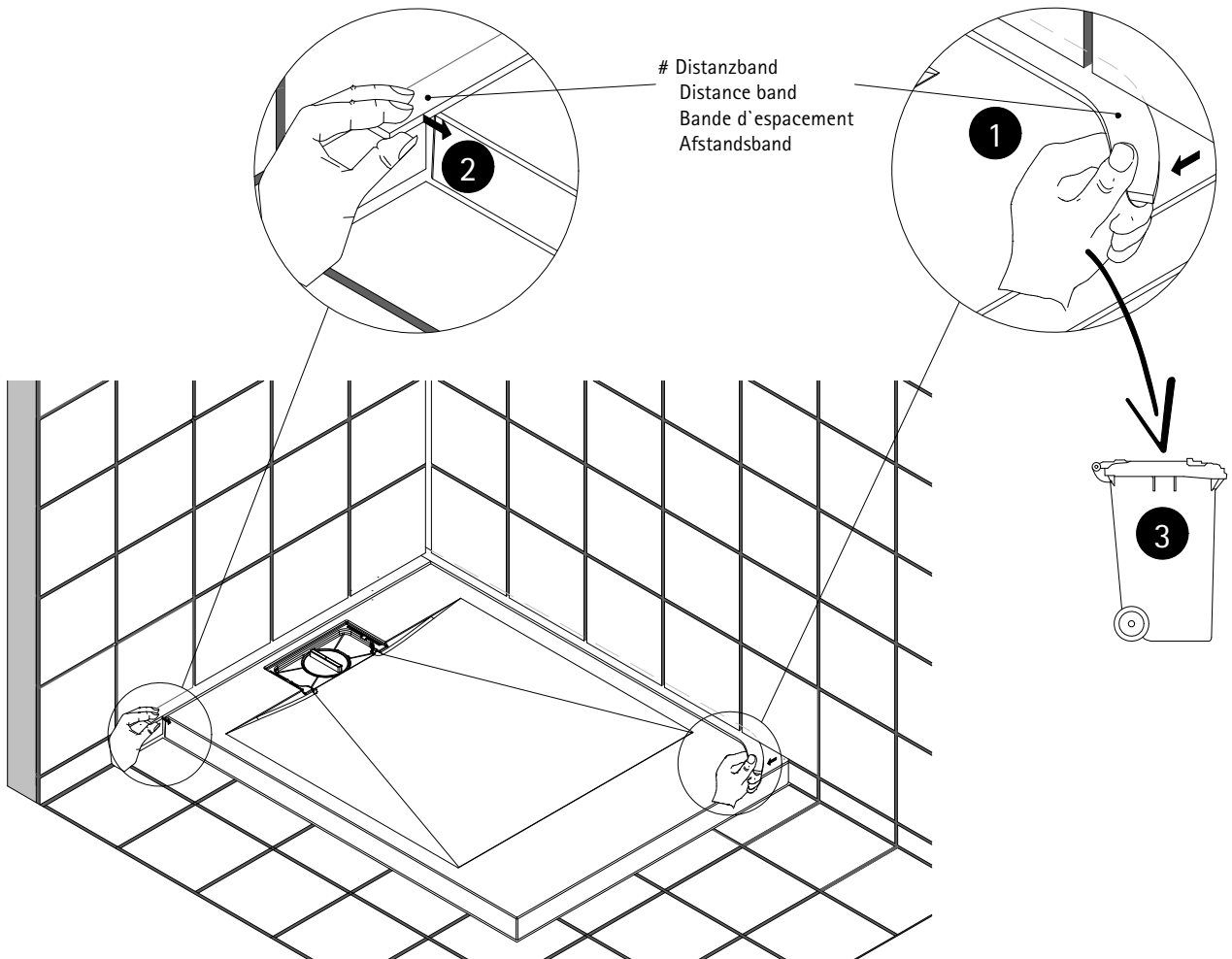

21

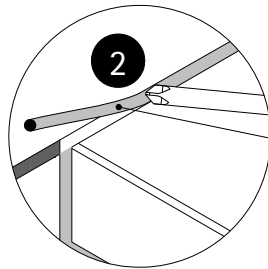

* Nicht im Lieferumfang enthalten.
not included in delivery.
non fourni dans l'emballage.
niet bij levering inbegrepen.

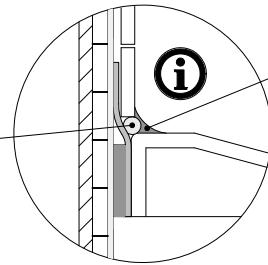

Silikon
silicone



- de Dichtschnur anbringen.
- en Insert sealing cord.
- fr Mettez en place le cordon d'étanchéité.
- nl Breng afdichtingskoord ann.

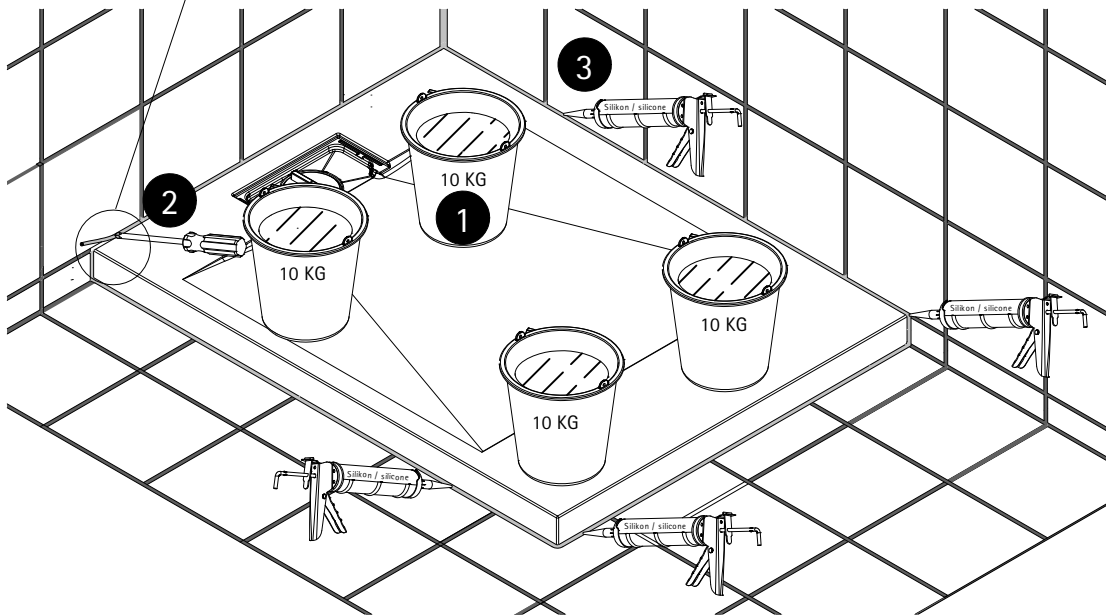

22

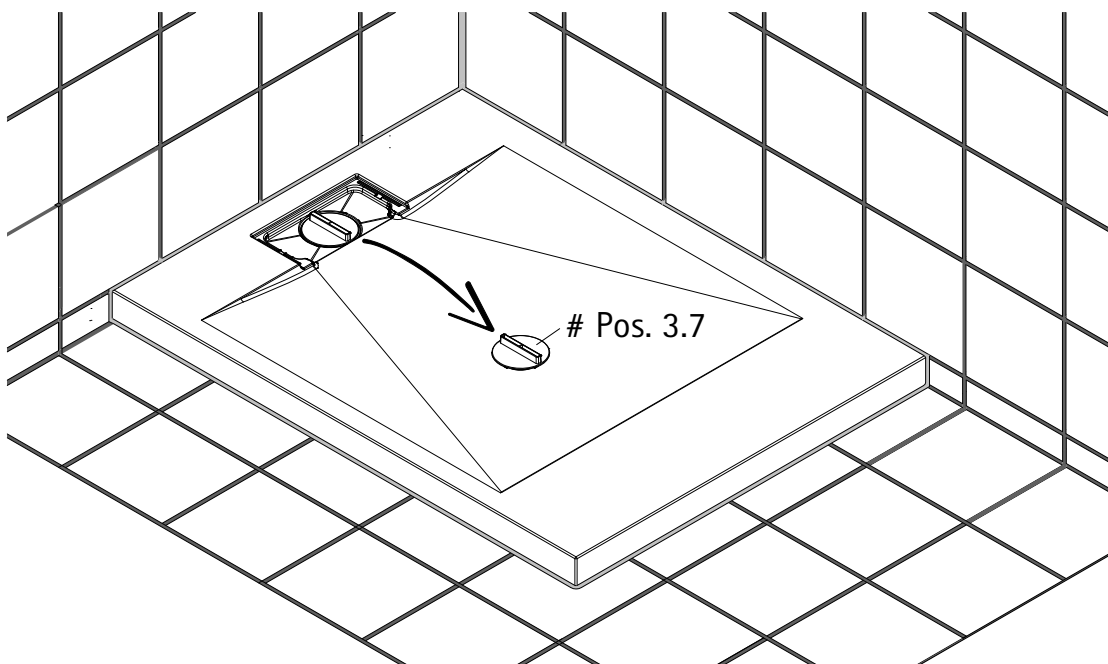

Optional lieferbar, optionally available, disponible en option, optioneel leverbaar

23

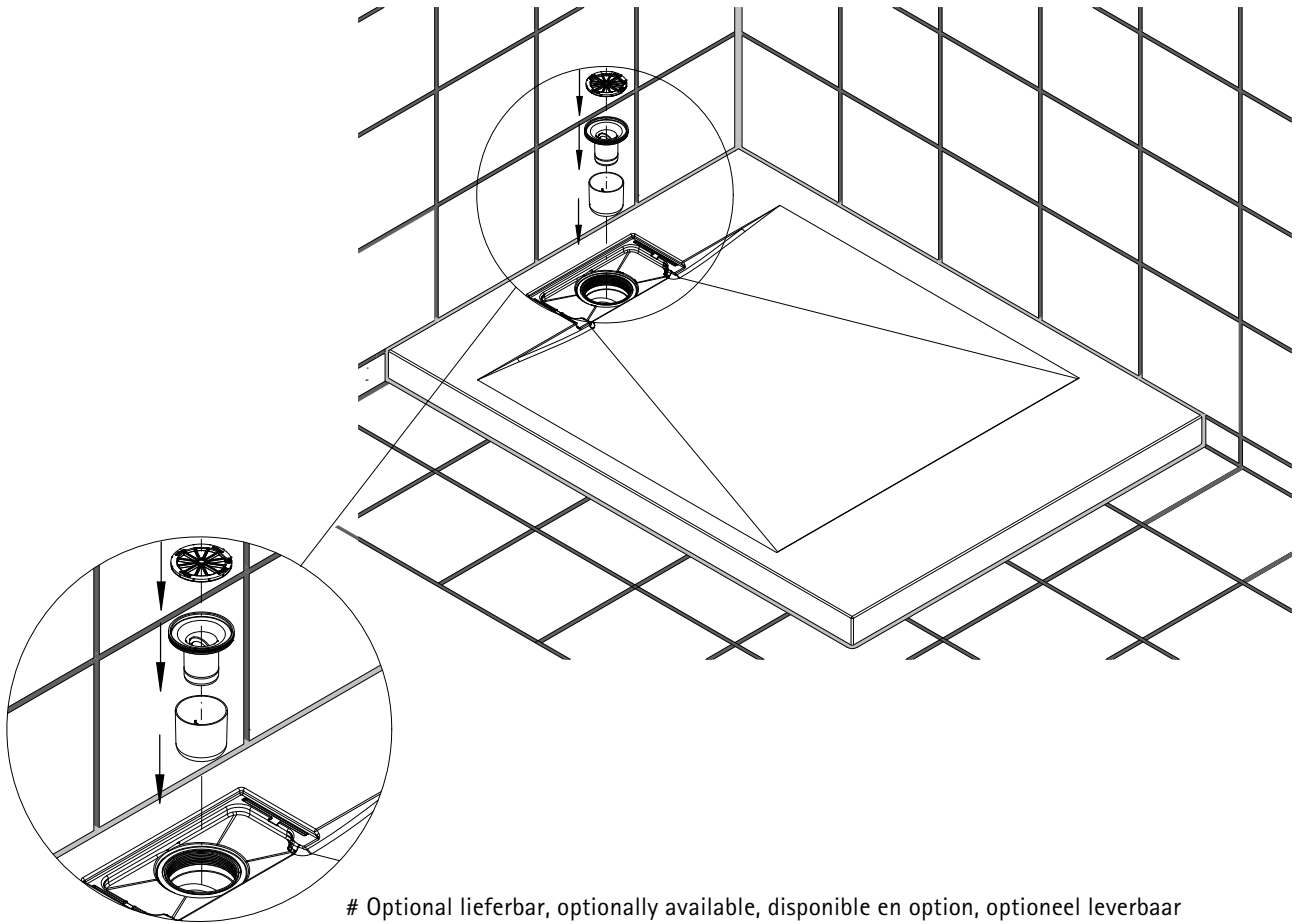

Optional lieferbar, optionally available, disponible en option, optioneel leverbaar

24



de Eine regelmäßige Reinigung im Ablaufbereich unter der Ablaufabdeckung wird empfohlen.

en Regular cleaning in the drain area under the drain cover is recommended!

fr Un nettoyage régulier dans la zone d'écoulement sous le couvercle d'écoulement est recommandé!

1

nl Regelmatige reiniging van het afvoergebied onder het putdeksel wordt aanbevolen!

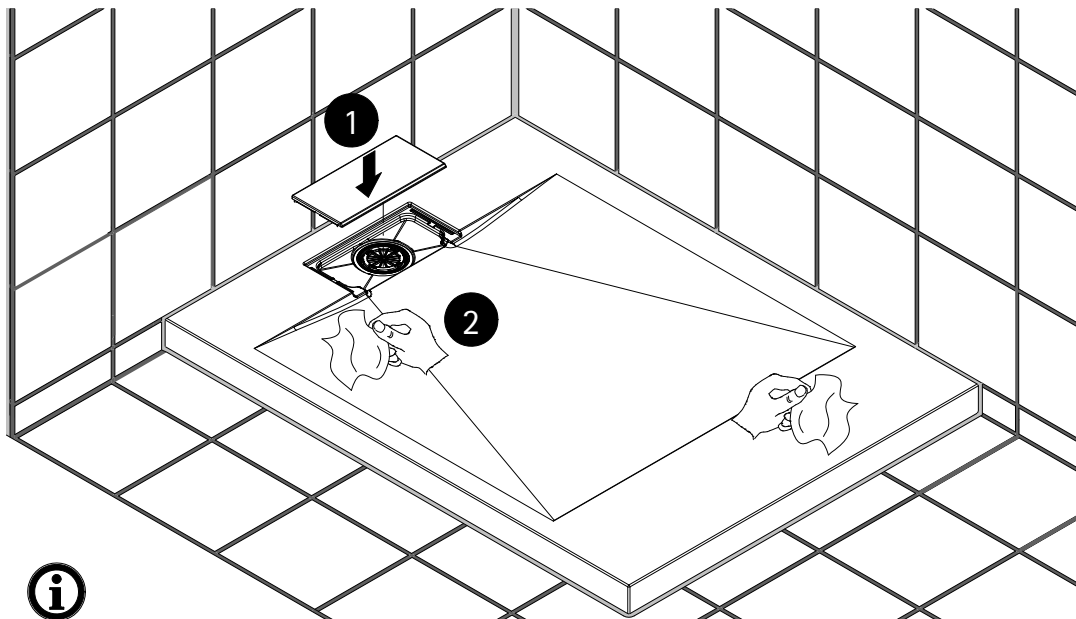

2

de Vor Erstbenutzung reinigen

en Clean before first use

fr Veuillez nettoyer avant la première utilisation

nl Vóór het eerste gebruik a.u.b. reinigen

Montageanleitung Installation instructions Instructions de montage Montagehandleiding

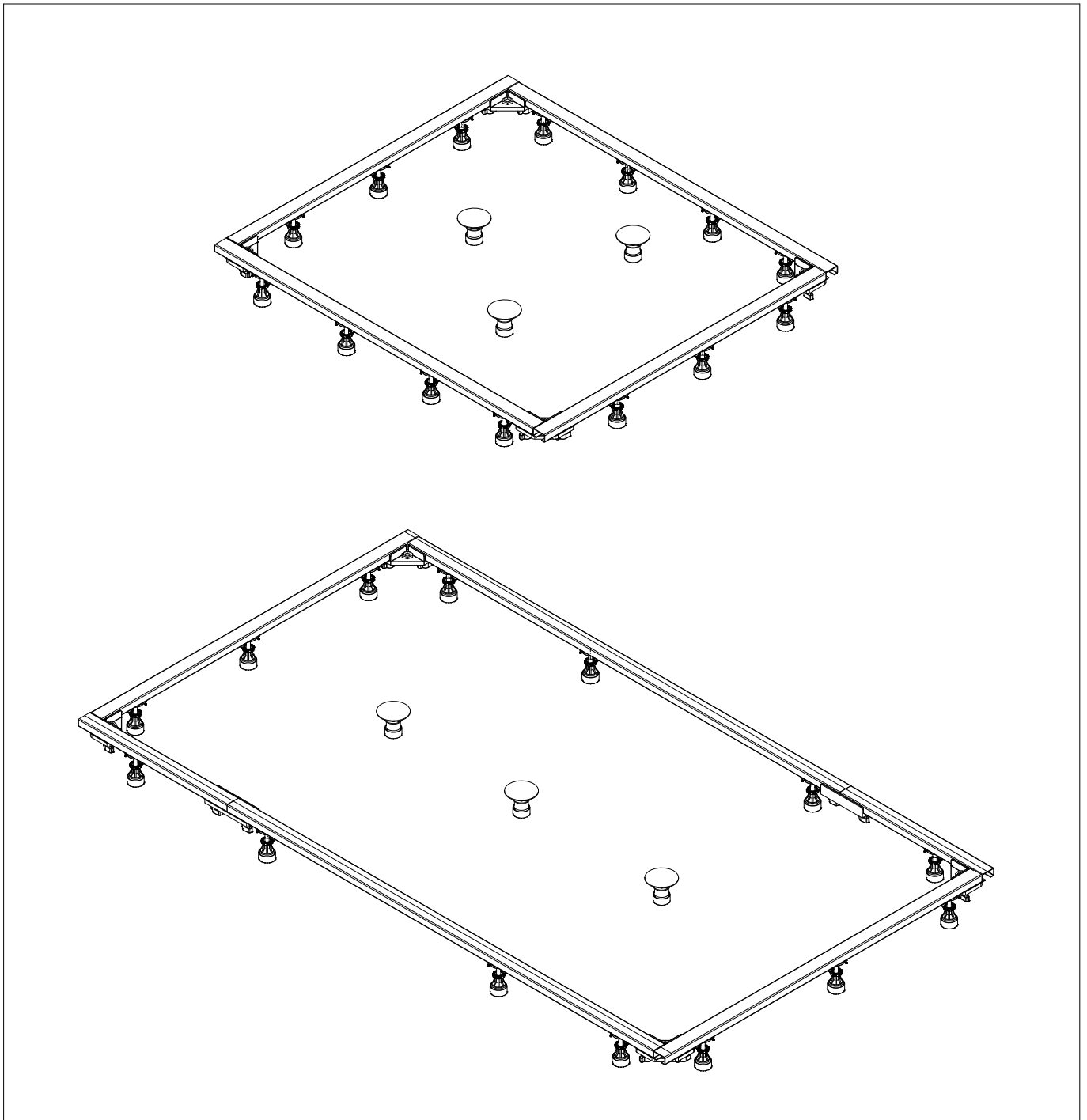

Sicherheitshinweise, Safty instructions, Consignes de sécurité, Veiligheidsaanwijzingen

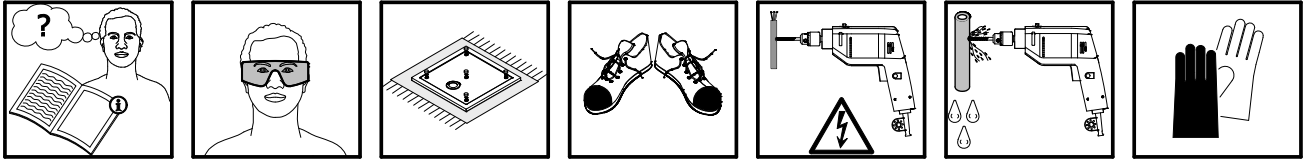

i Benötigtes Werkzeug, Tool needed, outillage nécessaire, Benodigd gereedschap

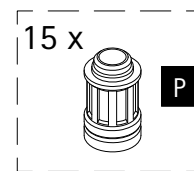
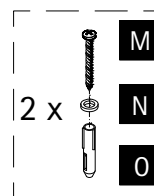
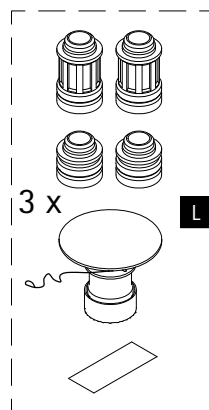
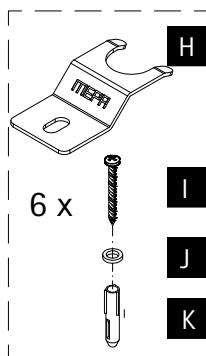
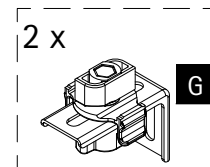
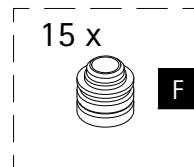
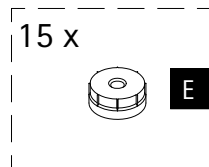
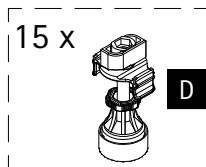
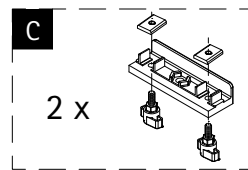
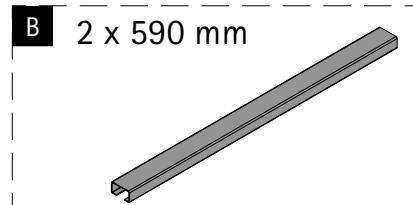
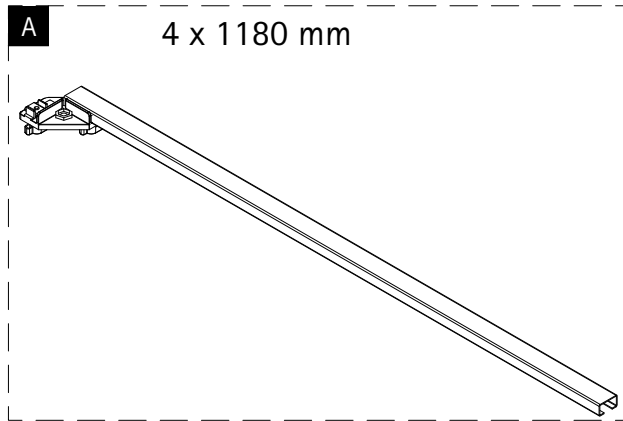
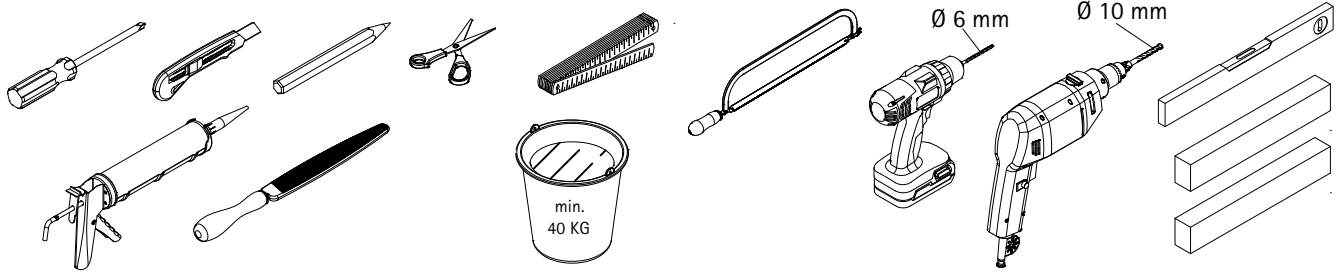

1a

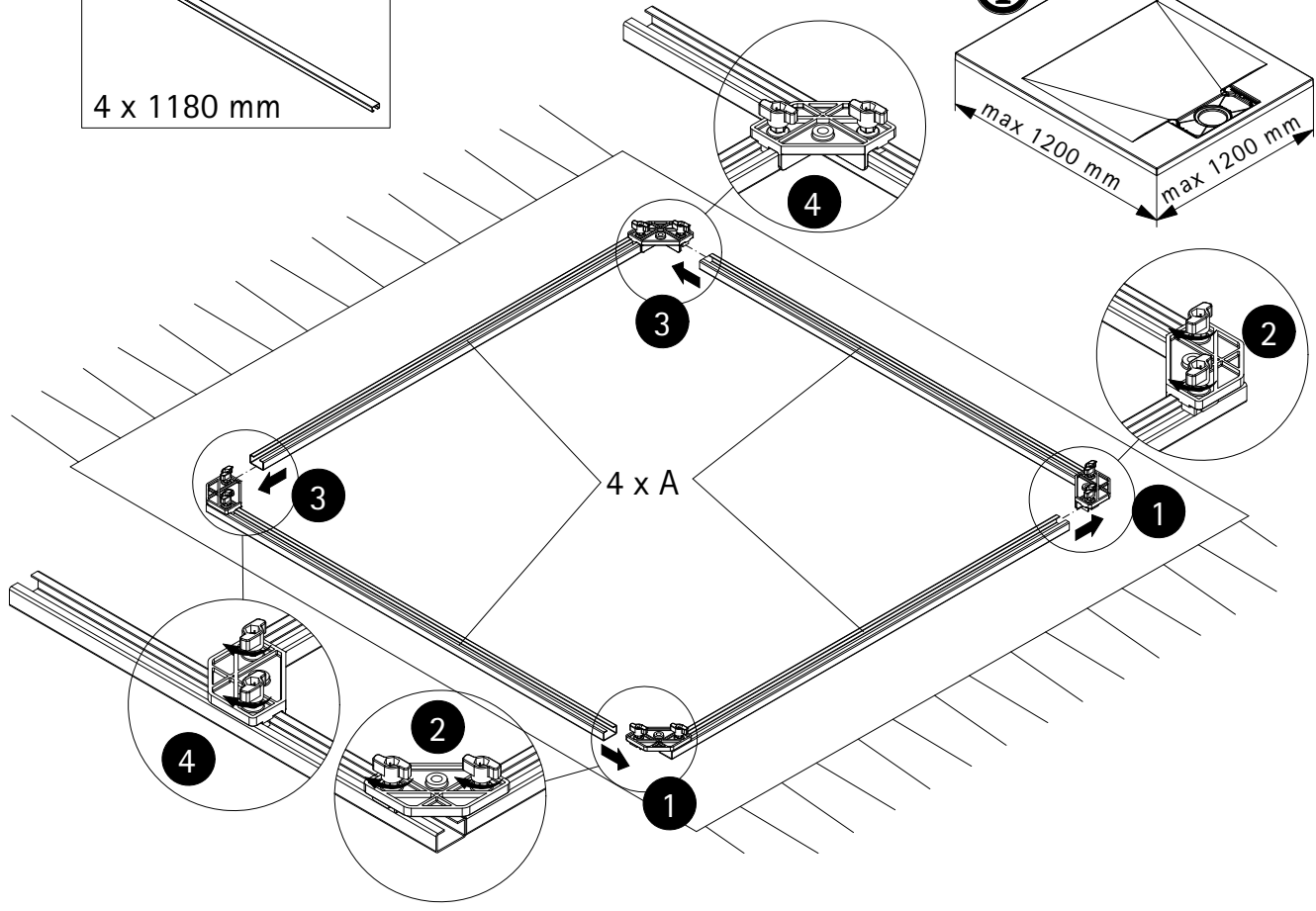
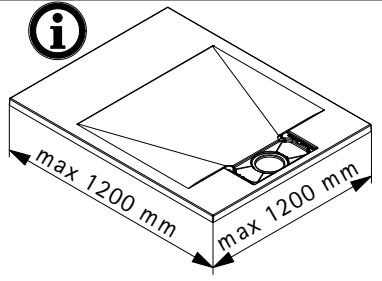
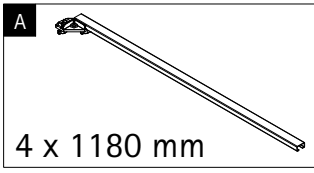

2a

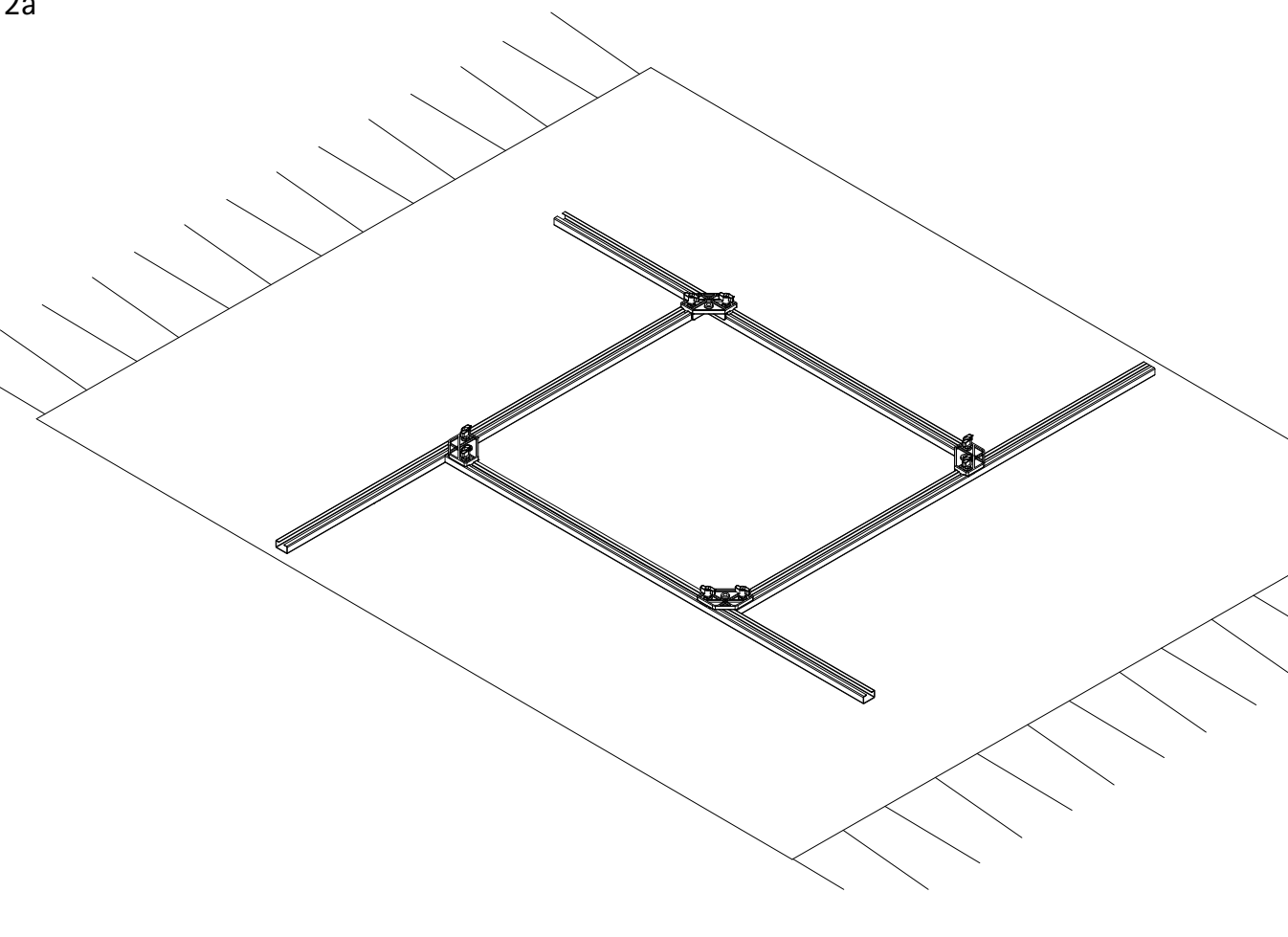

1b

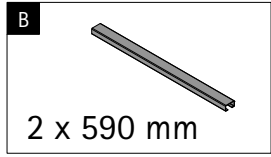
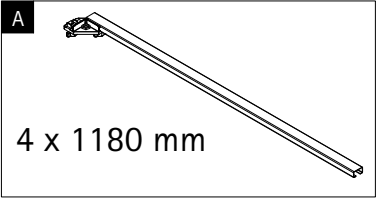

- i**
- de Ausrichtung der Verlängerungsprofile.
 - en Alignment of the extension profiles.
 - fr Alignement des profilés d'extension.
 - nl Uitlijning van de uitbreidingsprofielen.

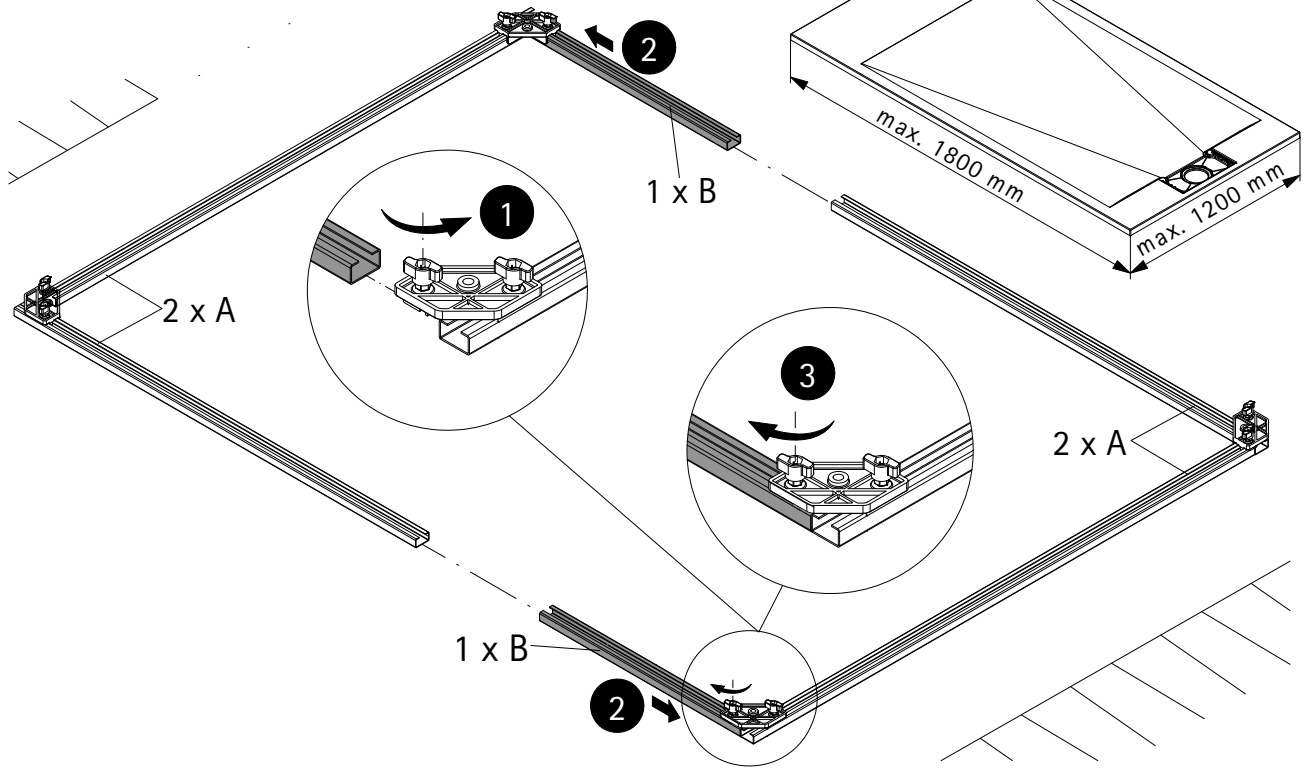

2b

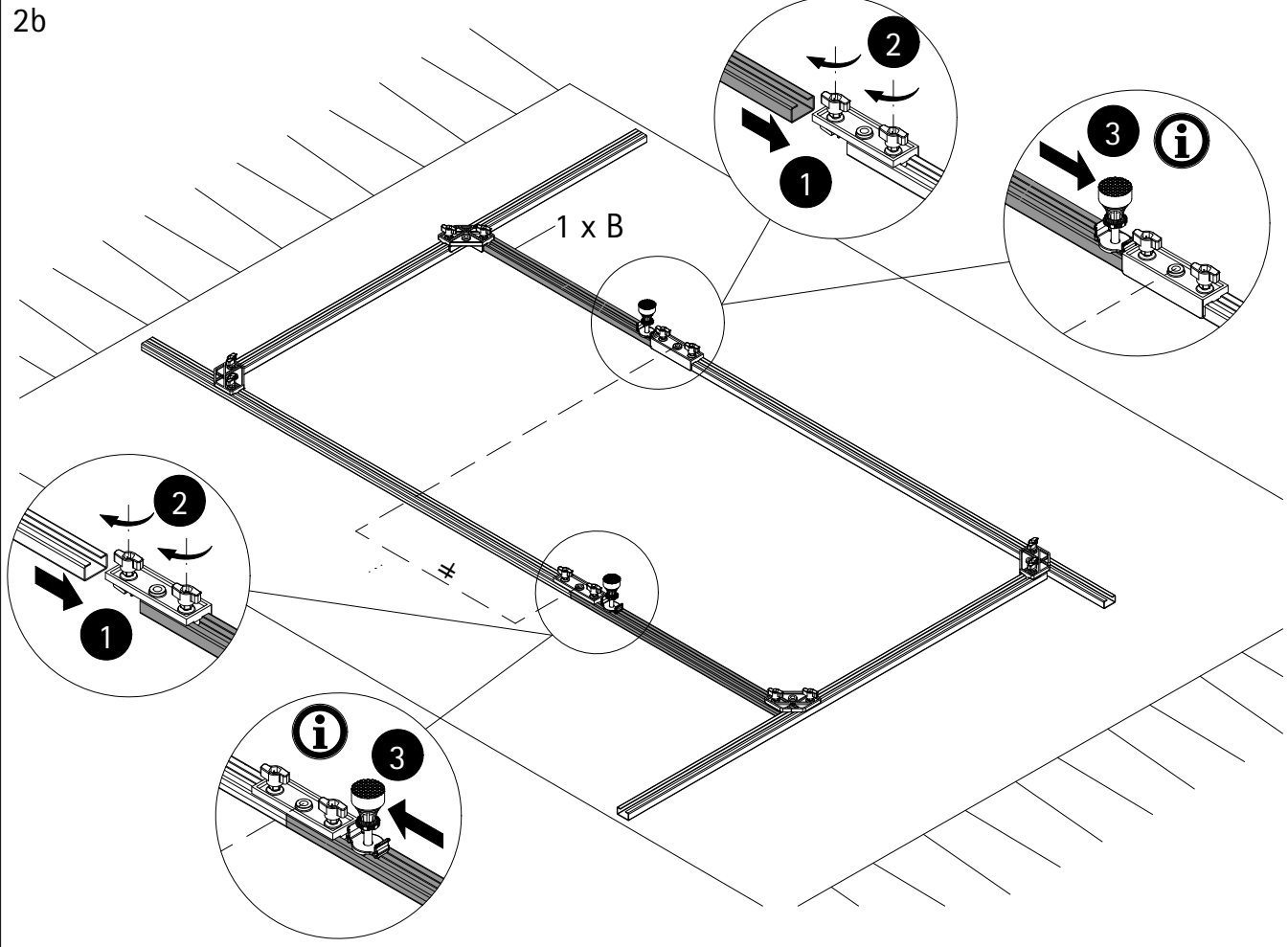

3

- de Rahmengröße einstellen.
- en Adjust frame size.
- fr Ajustez la taille du cadre.
- nl Pas de framegrootte aan.

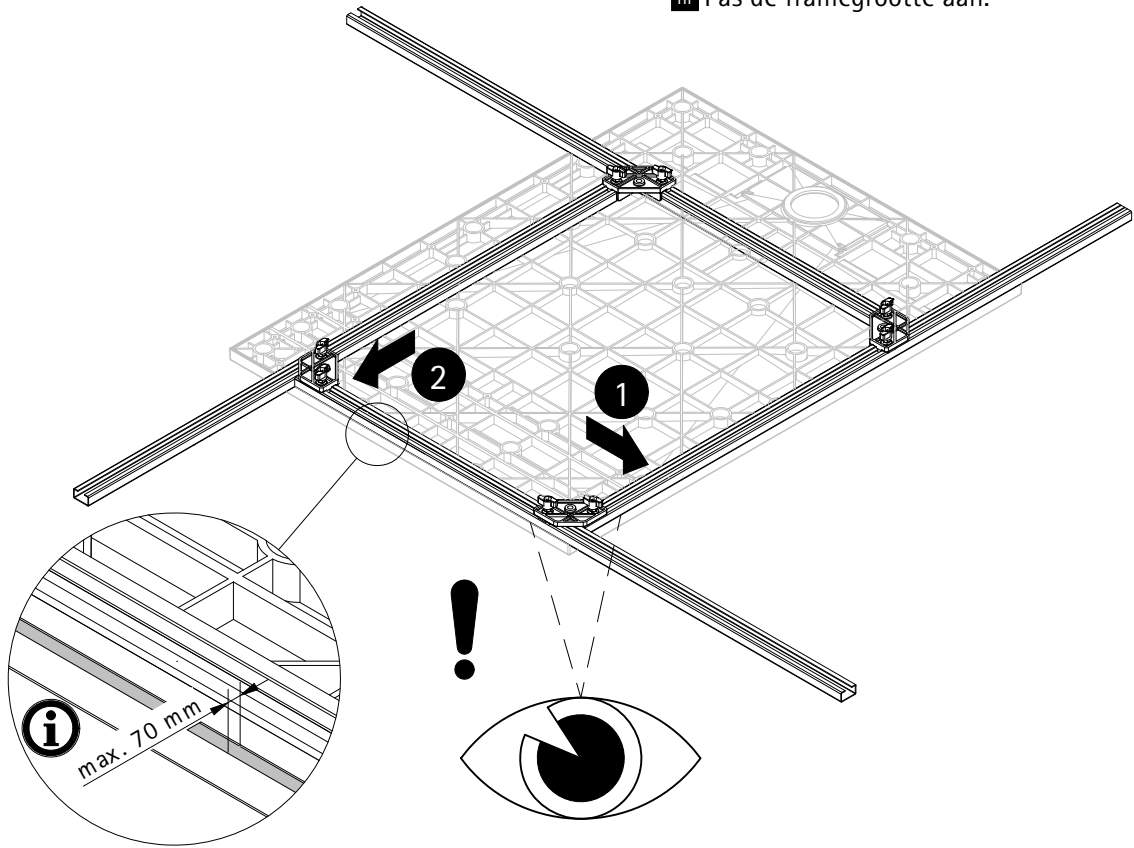

4

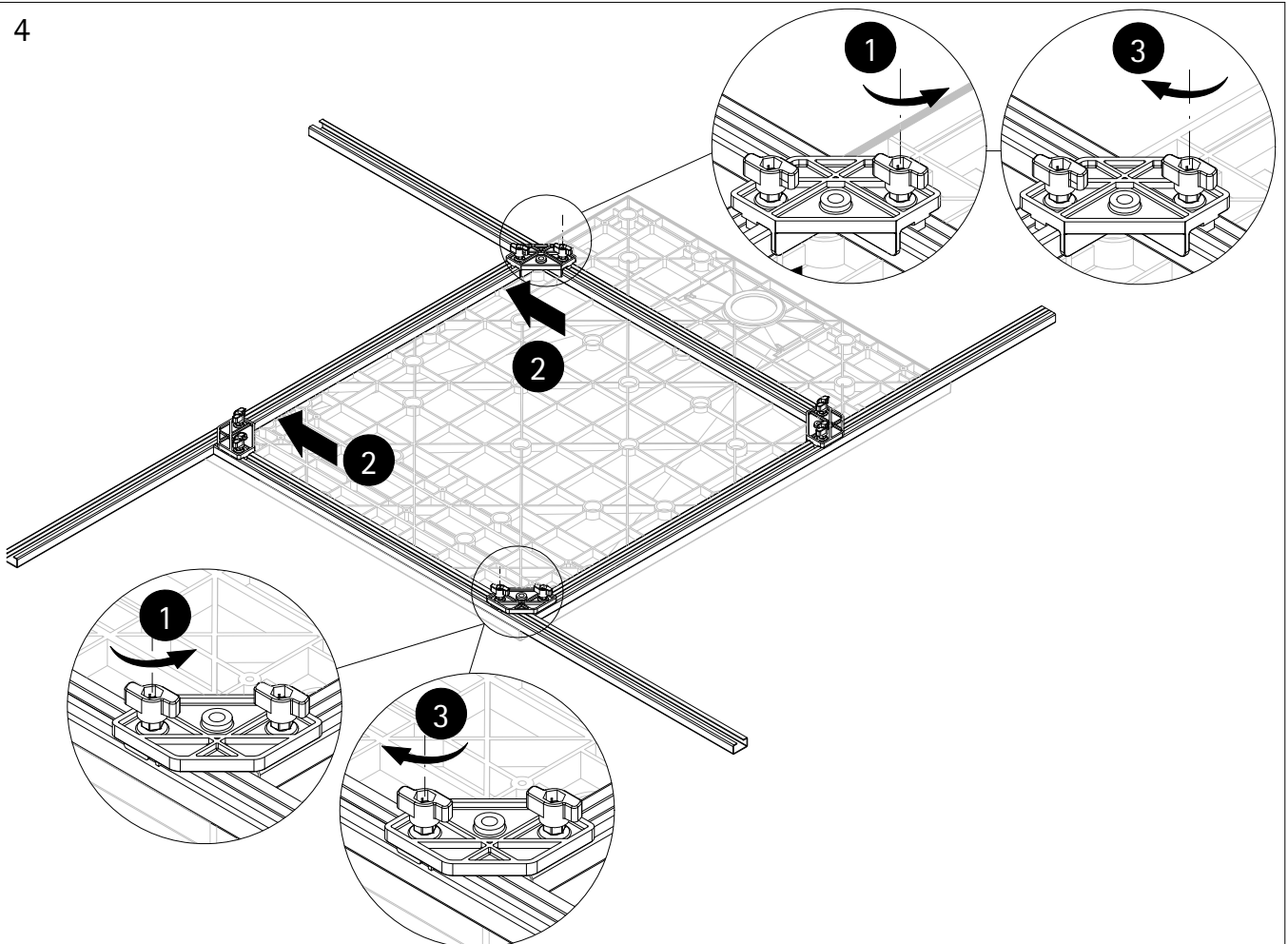

5

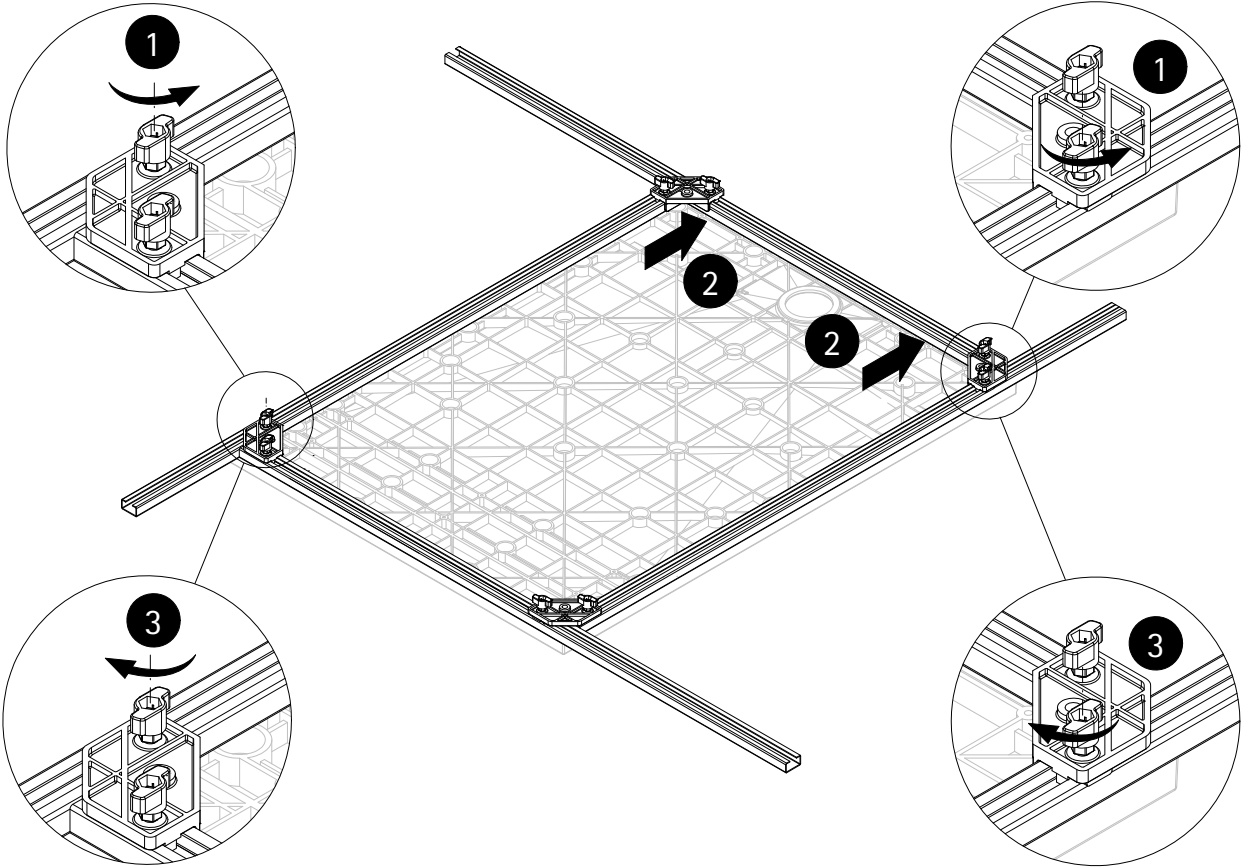

6

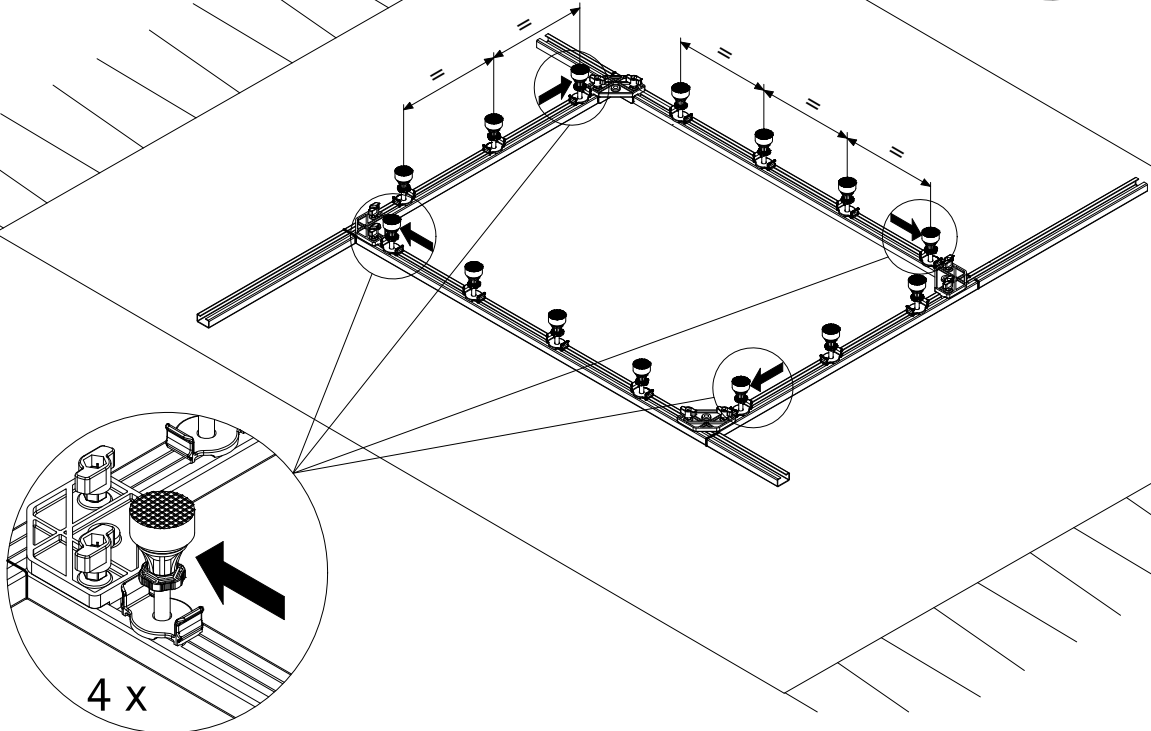
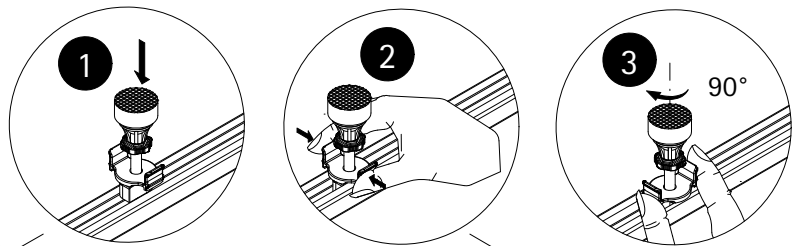
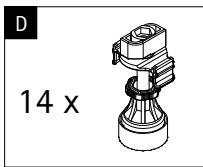

7

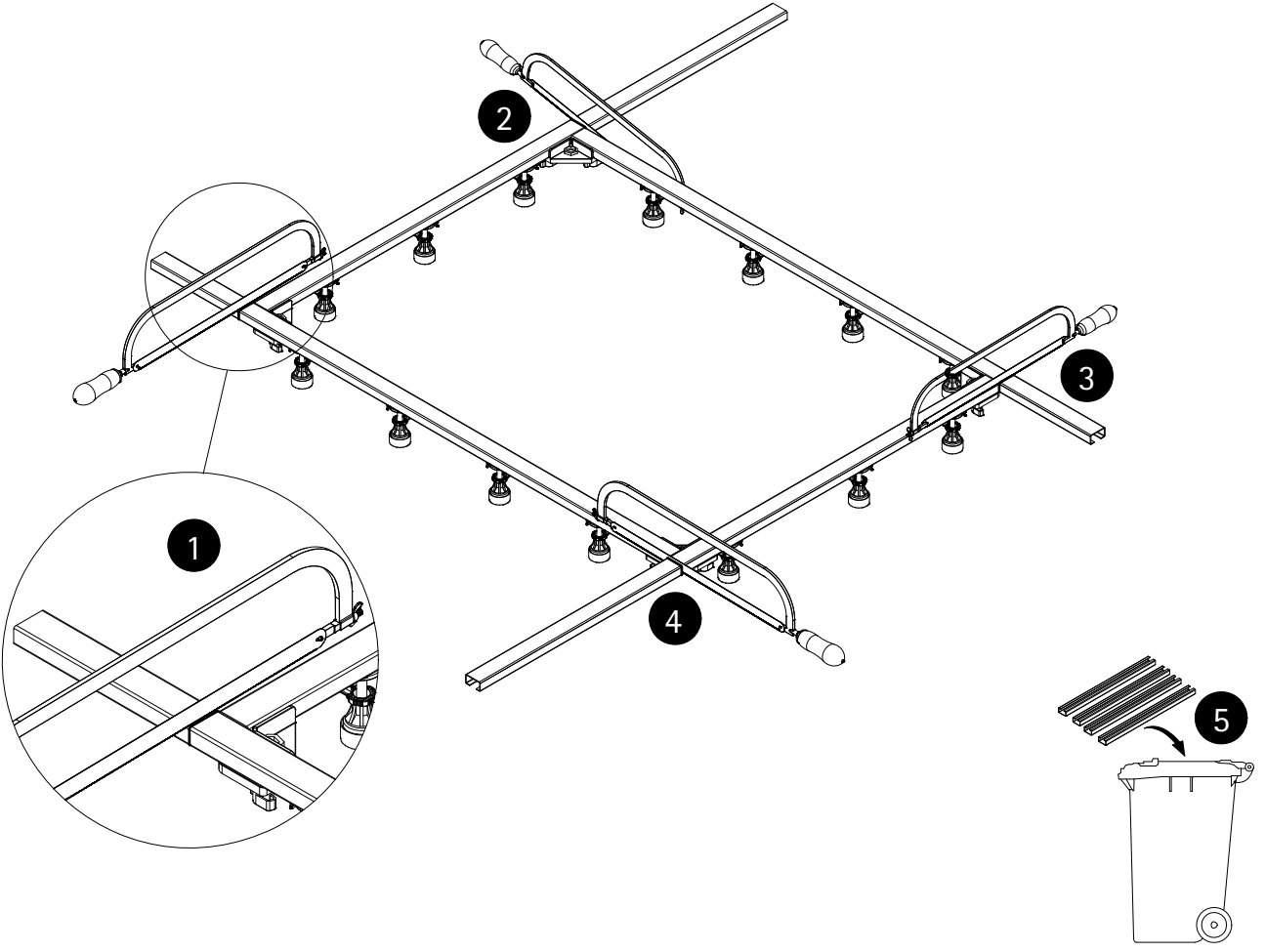

8

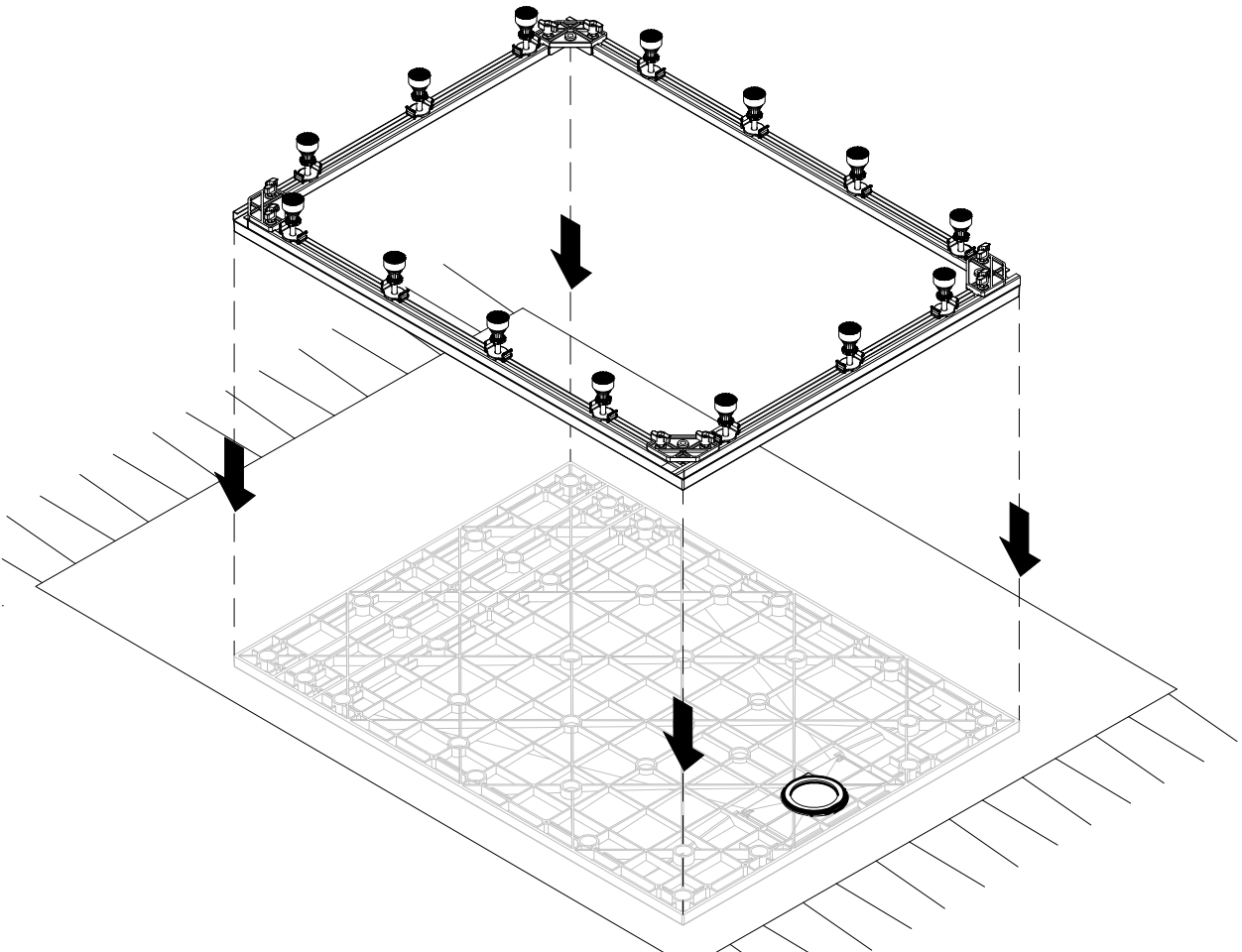

Info

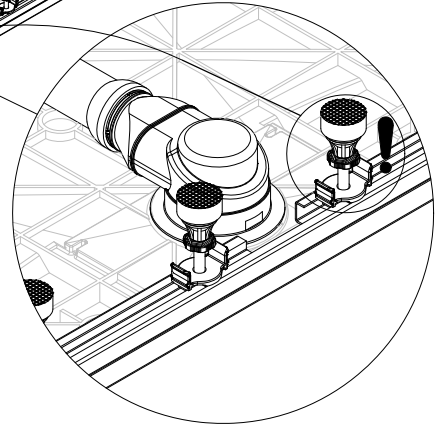
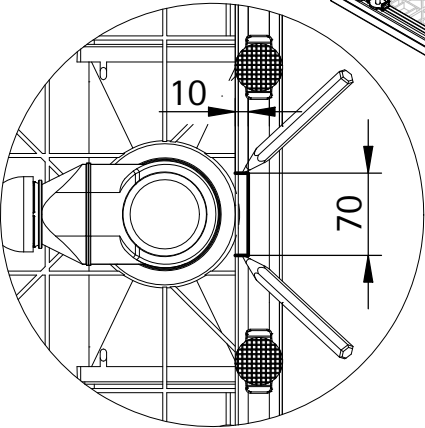
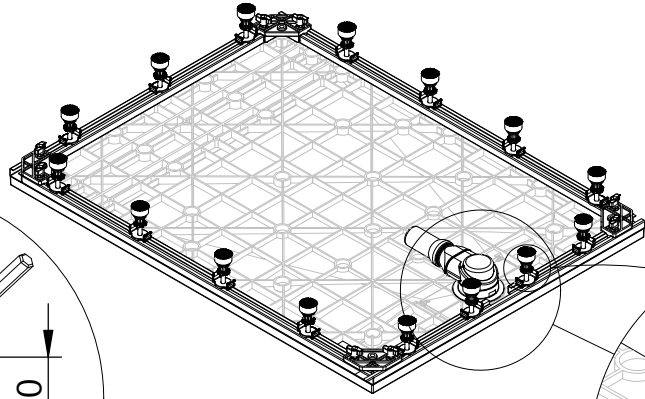
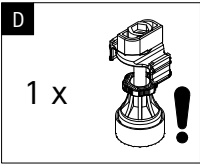

Optional lieferbar, optionally available, disponible en option, optioneel leverbaar

9

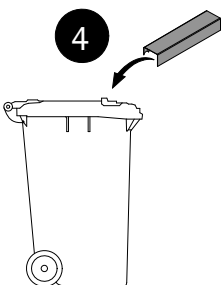
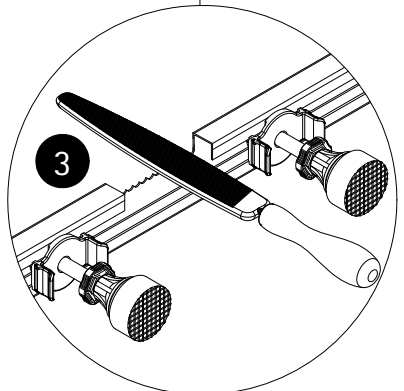
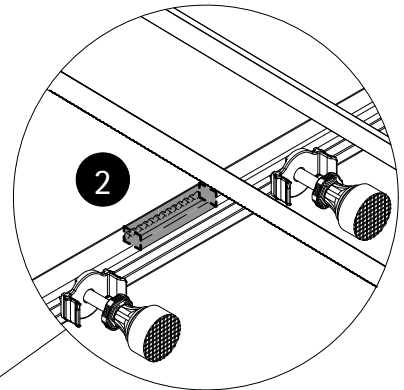
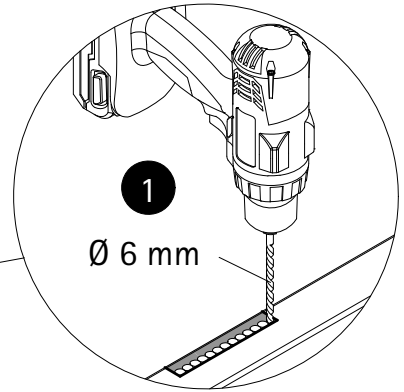
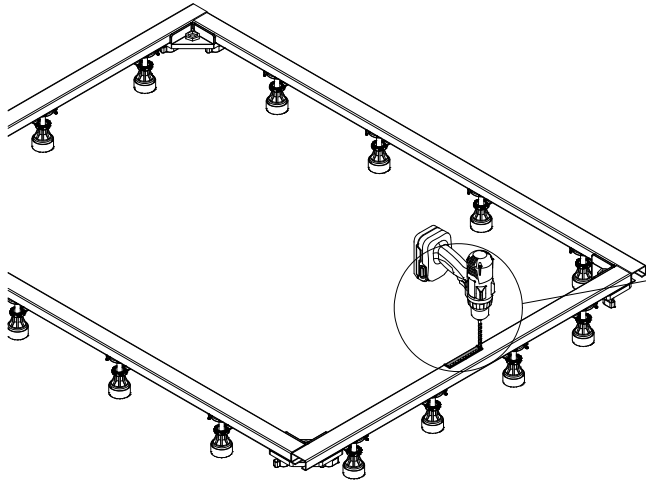
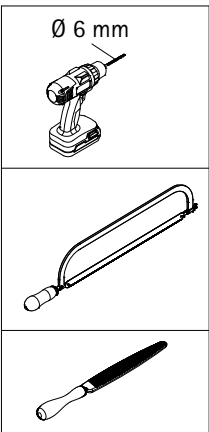

10

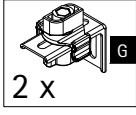
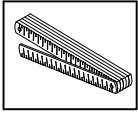

H = min 85 mm

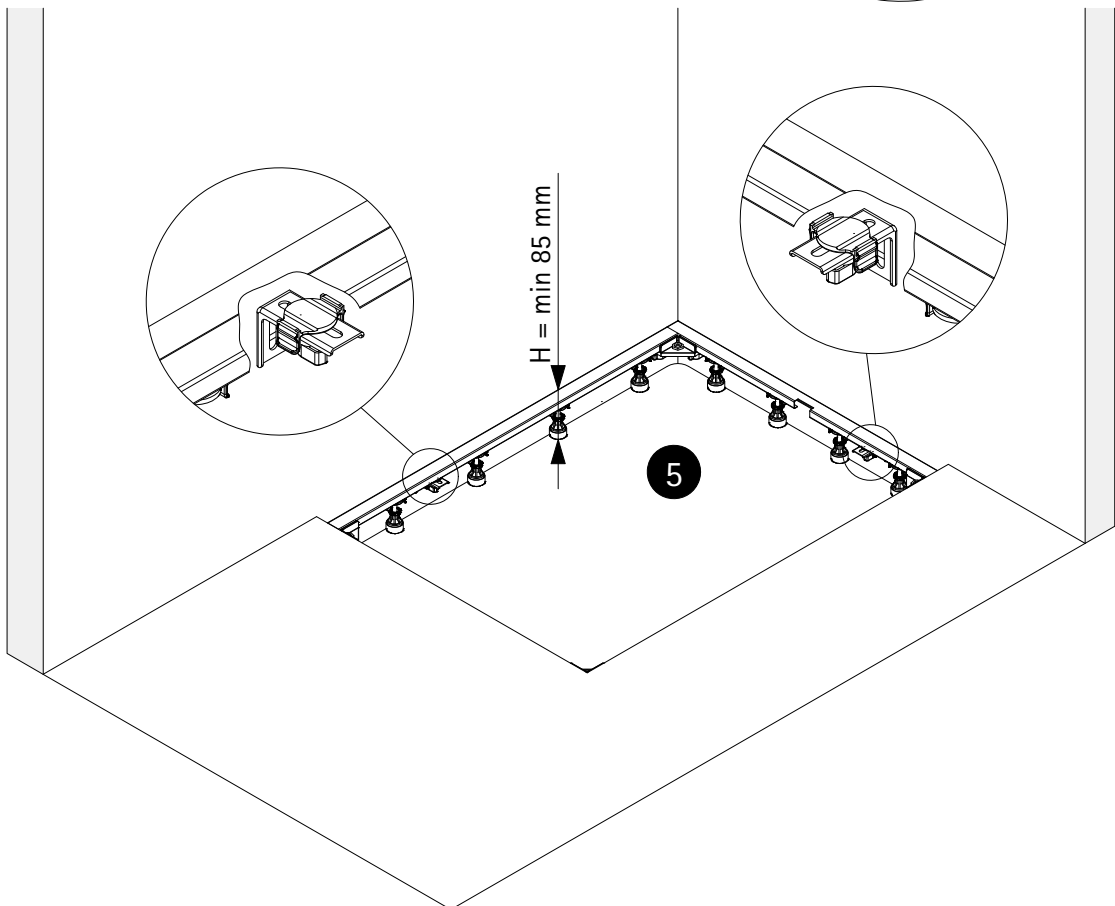
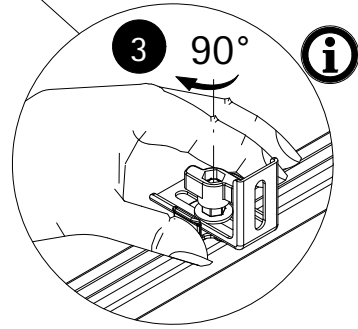
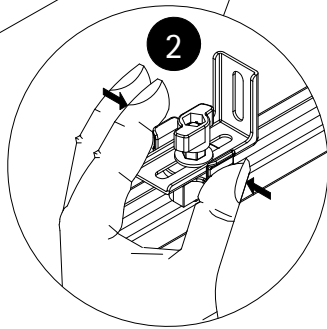
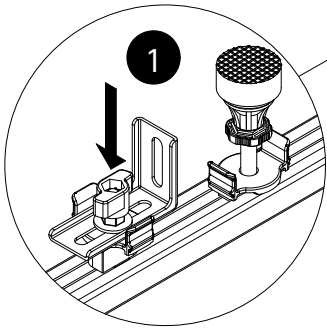
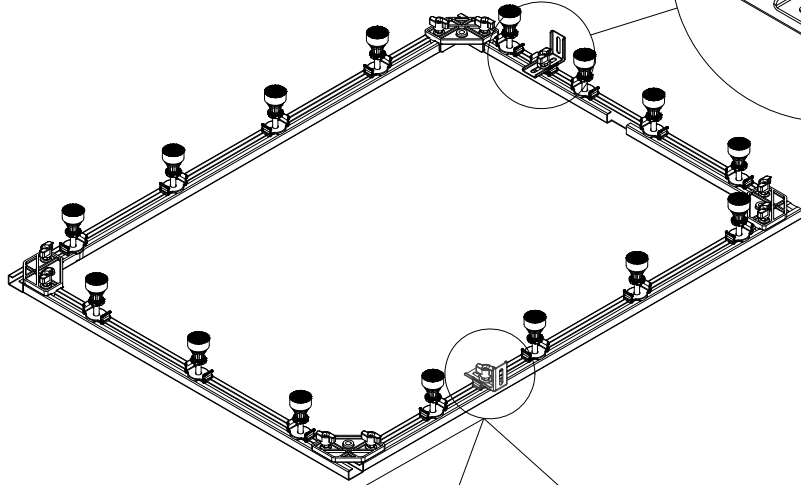
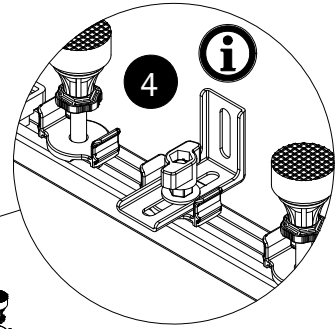

Info

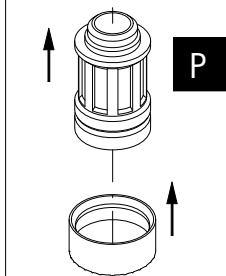
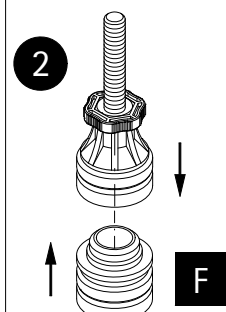
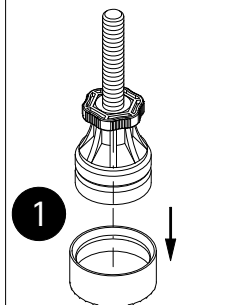
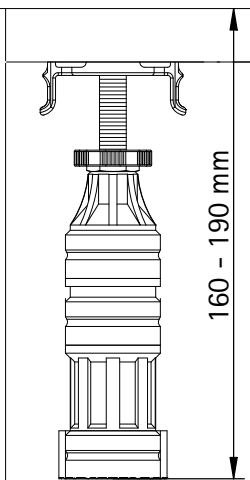
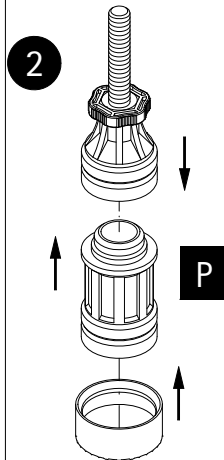
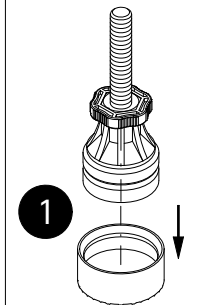
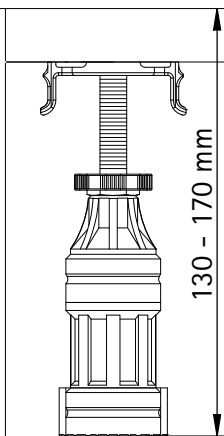
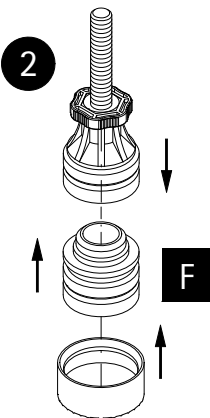
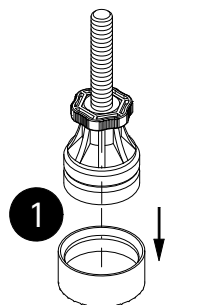
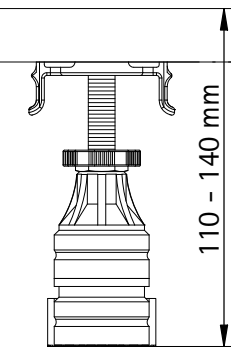
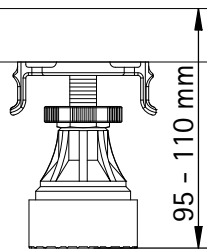
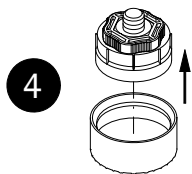
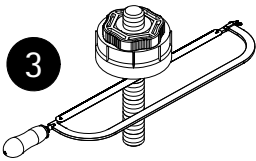
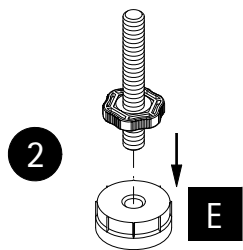
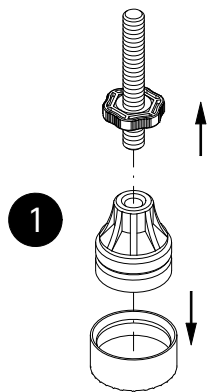
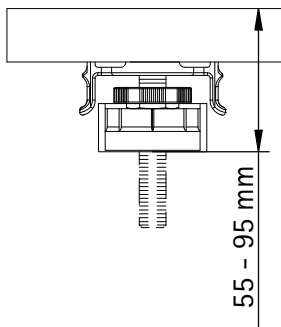
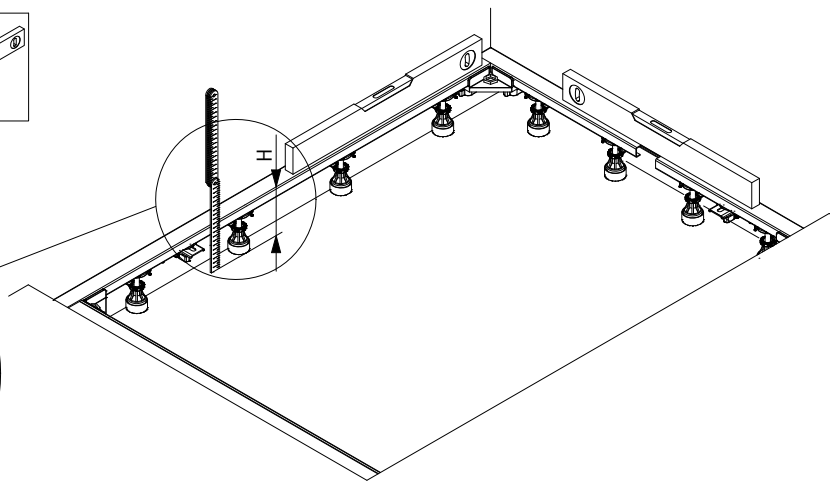
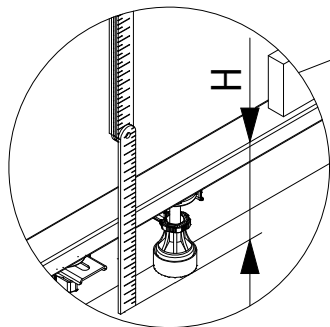
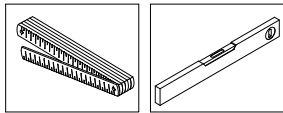

11

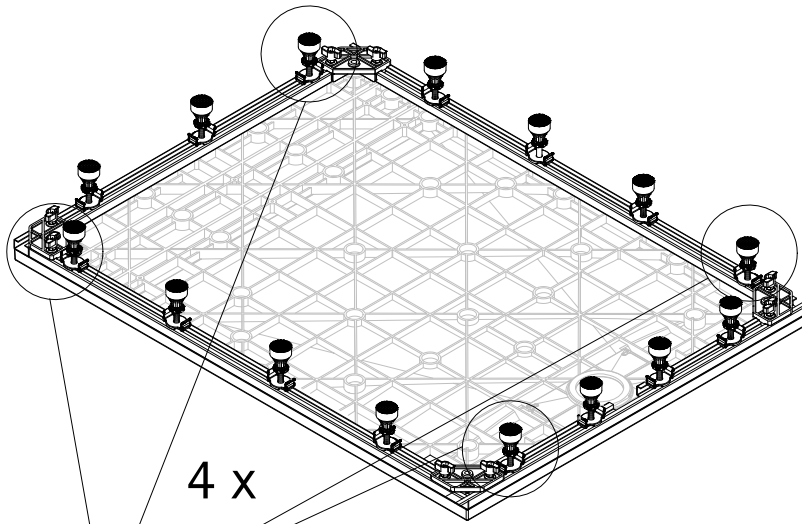
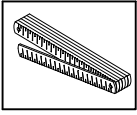

4 x

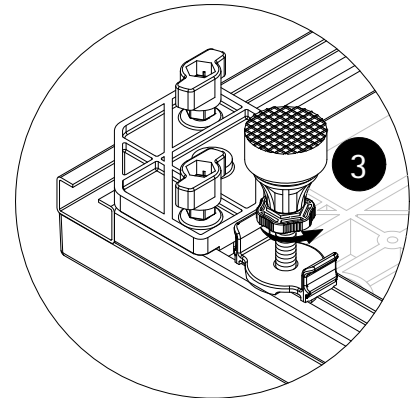
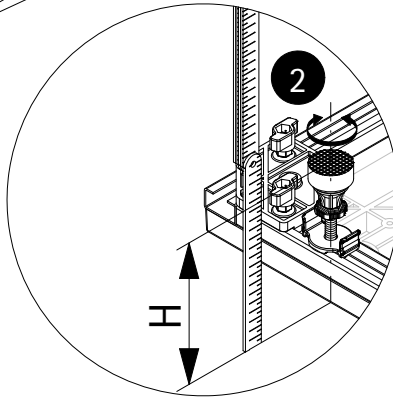
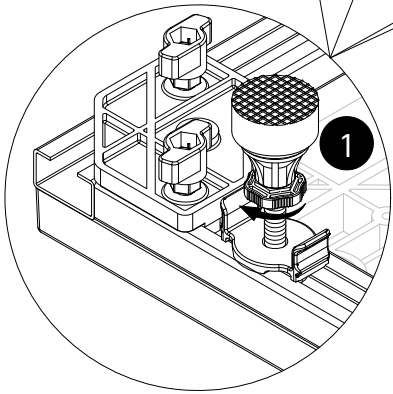

12

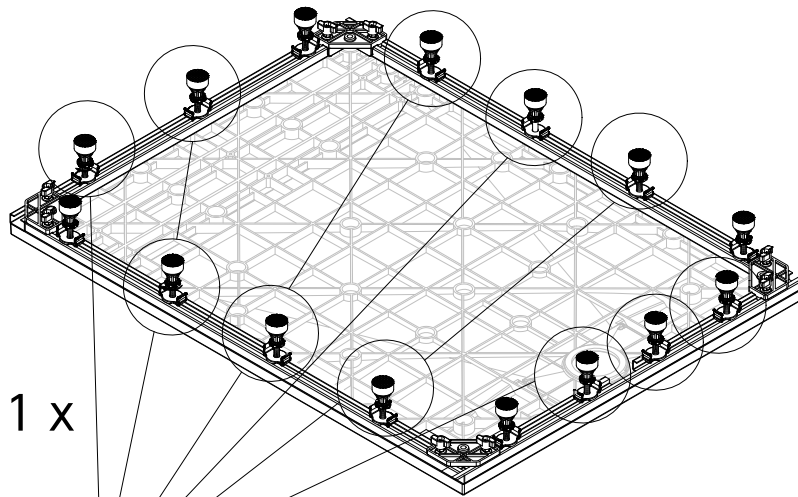
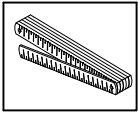

11 x

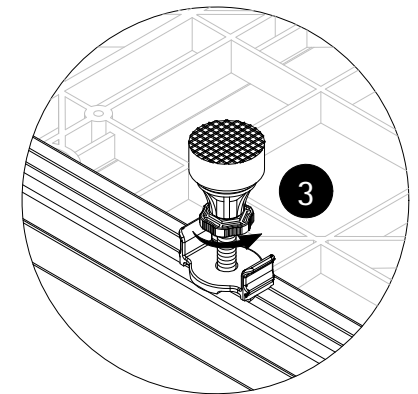
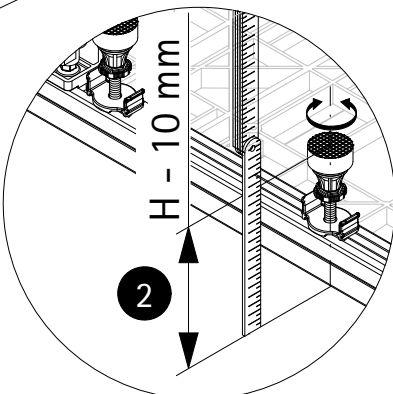
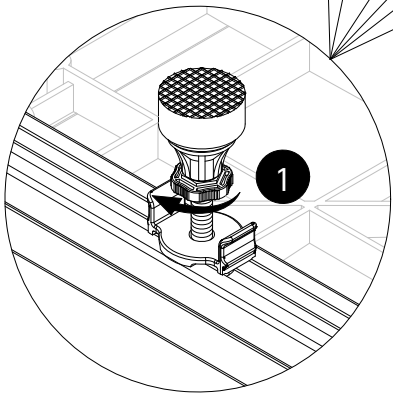

13

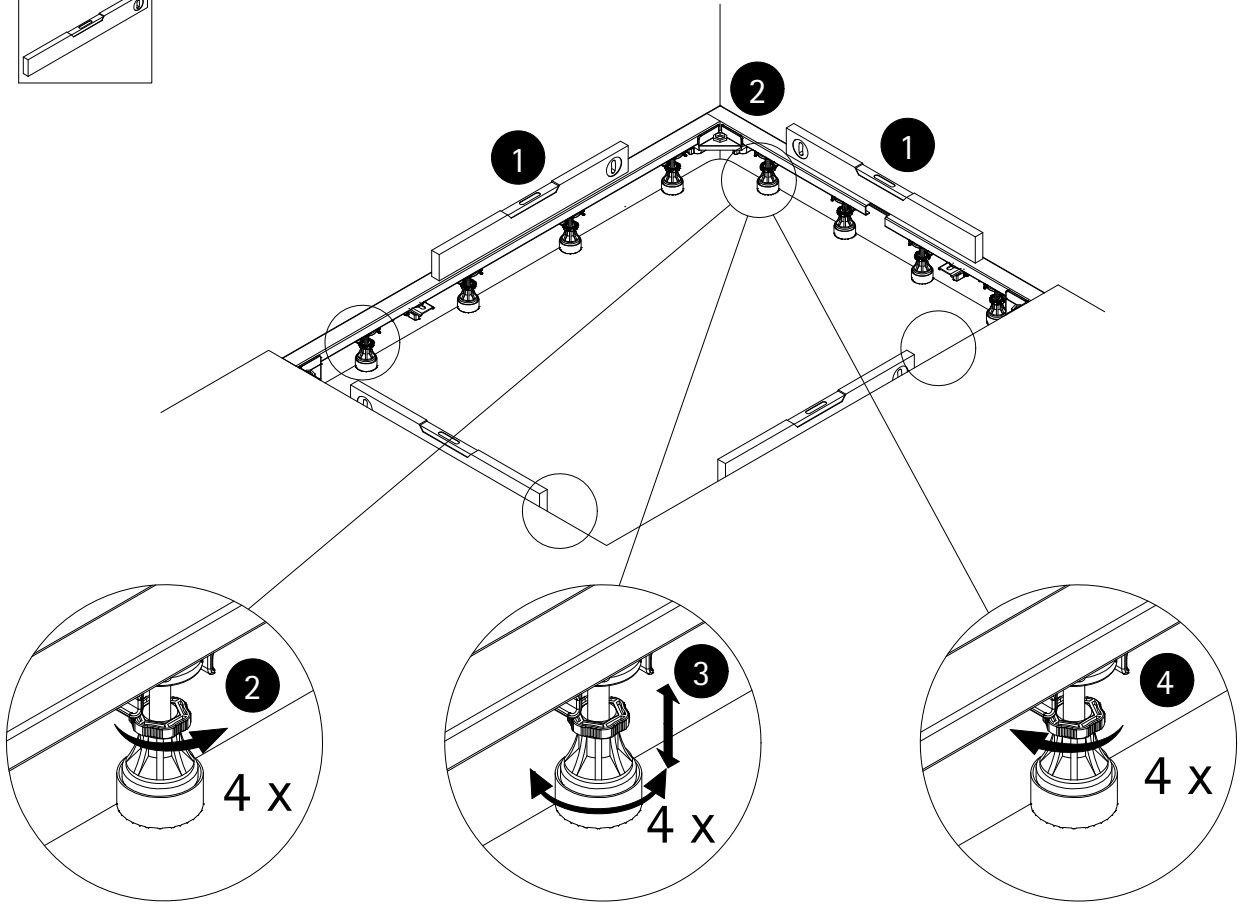
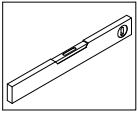

14

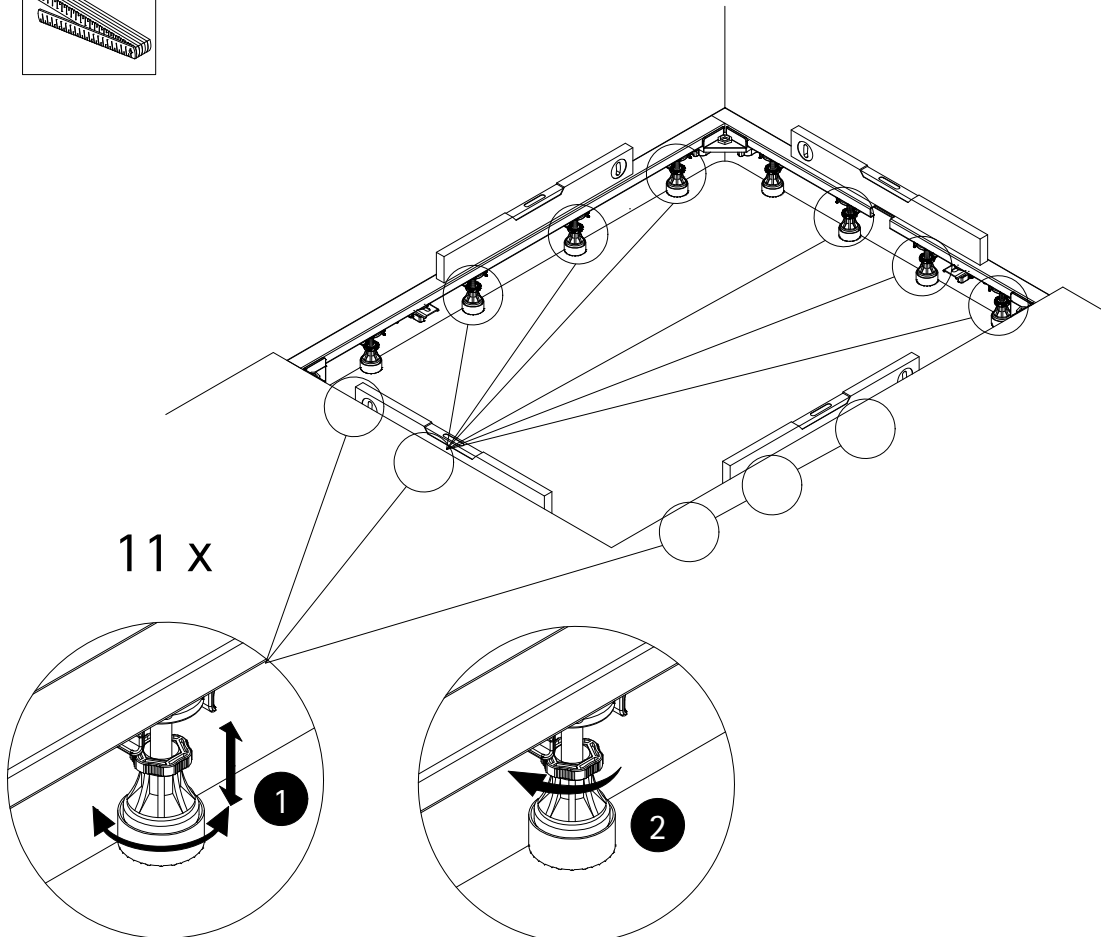
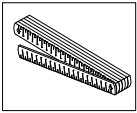

15.1

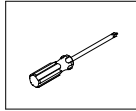
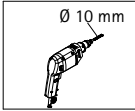
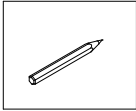
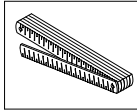

i (H ≤ 70 mm)

- 4 x **M**
- 4 x **N**
- 4 x **O**

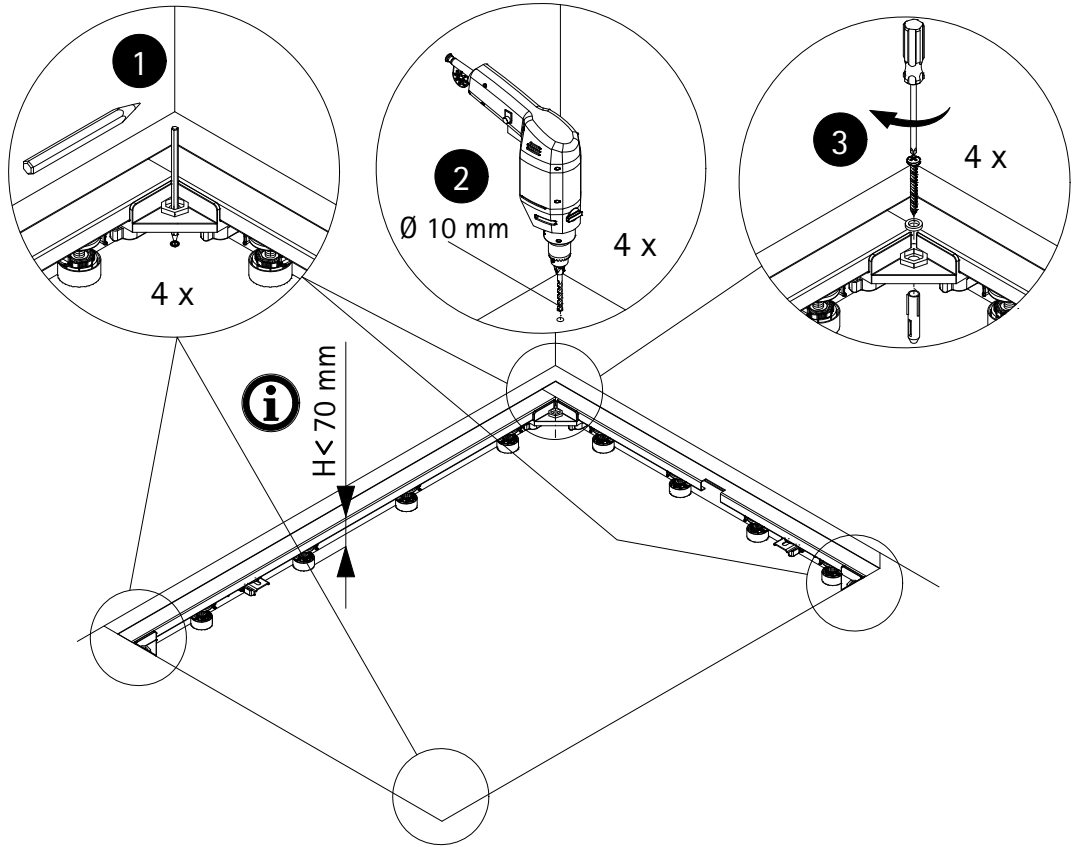

15.2

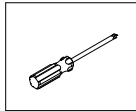
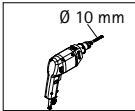
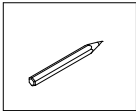
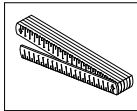

i (H > 70 mm)

- 6 x **H**
- 6 x **I**
- 6 x **J**
- 6 x **K**

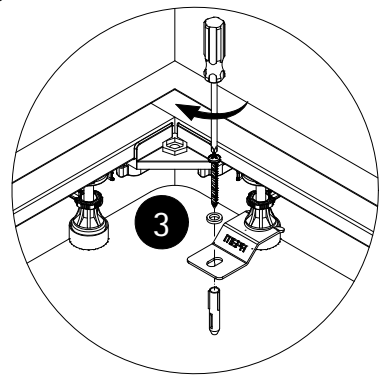
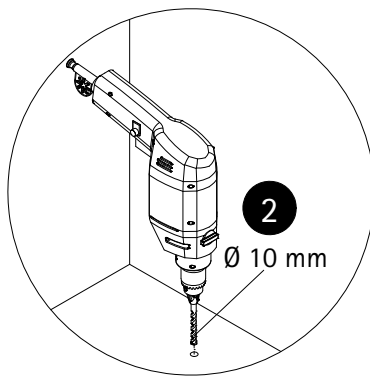
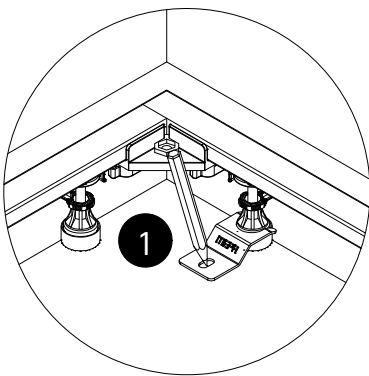
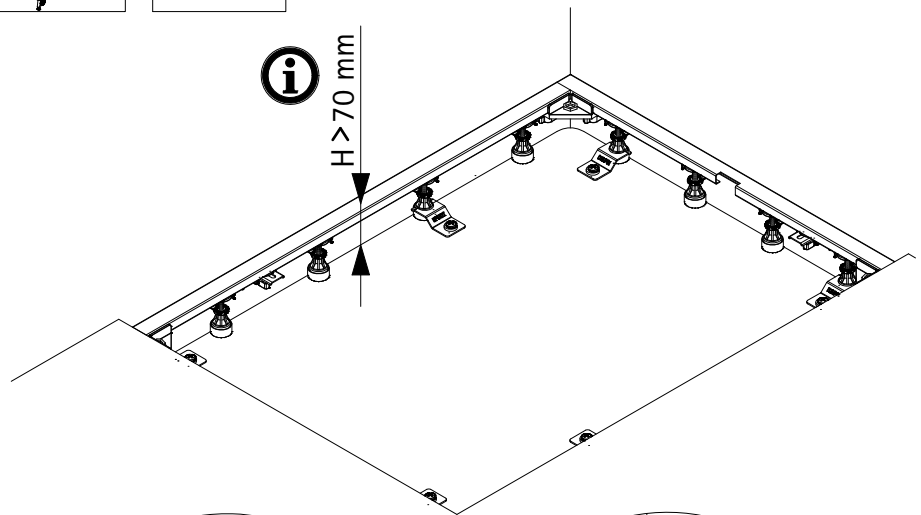

16

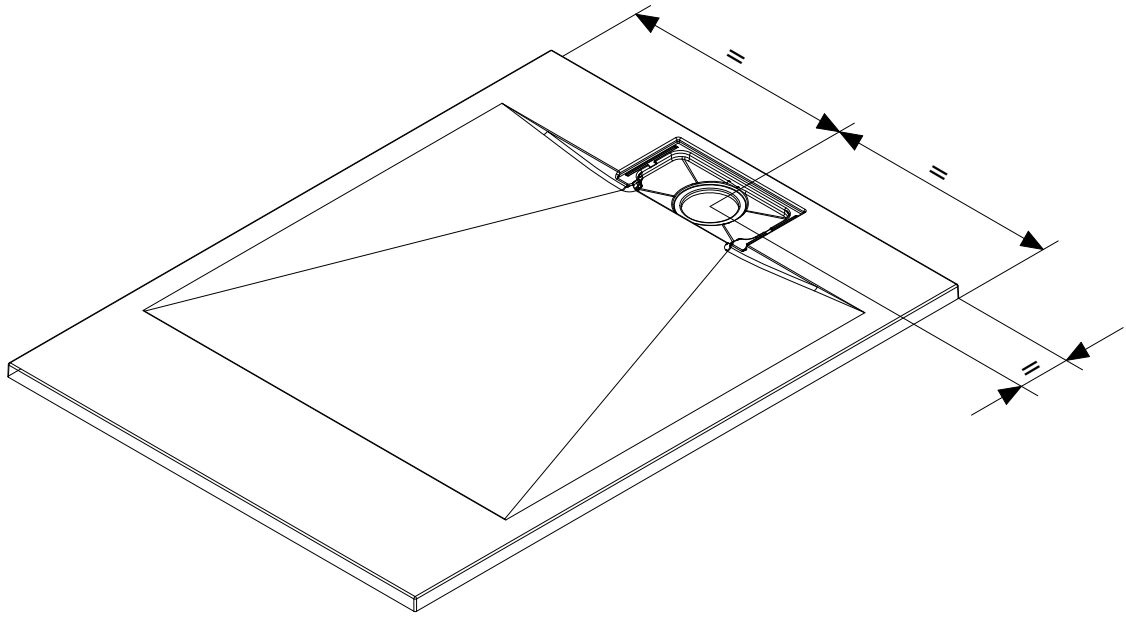
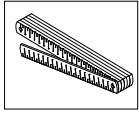

17

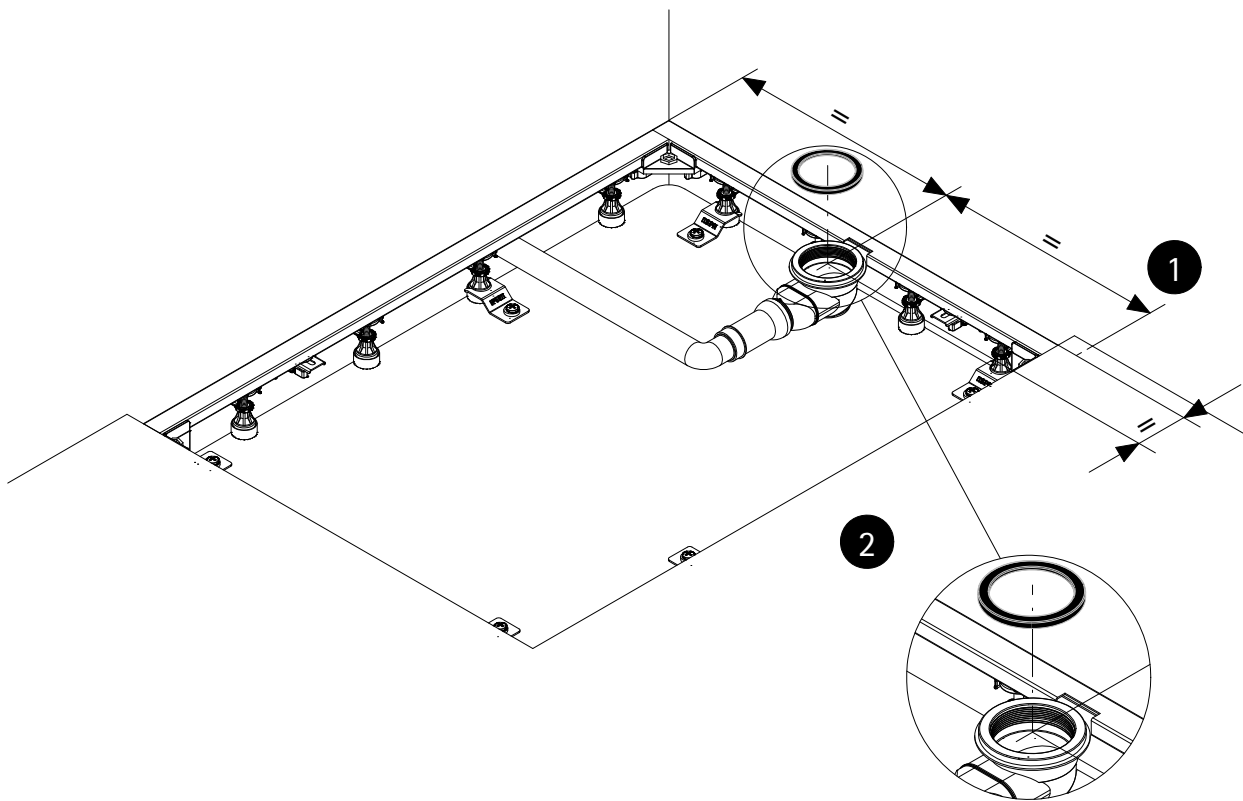

Optional lieferbar, optionally available, disponible en option, optioneel leverbaar

Info

i ($H \leq 160$ mm)

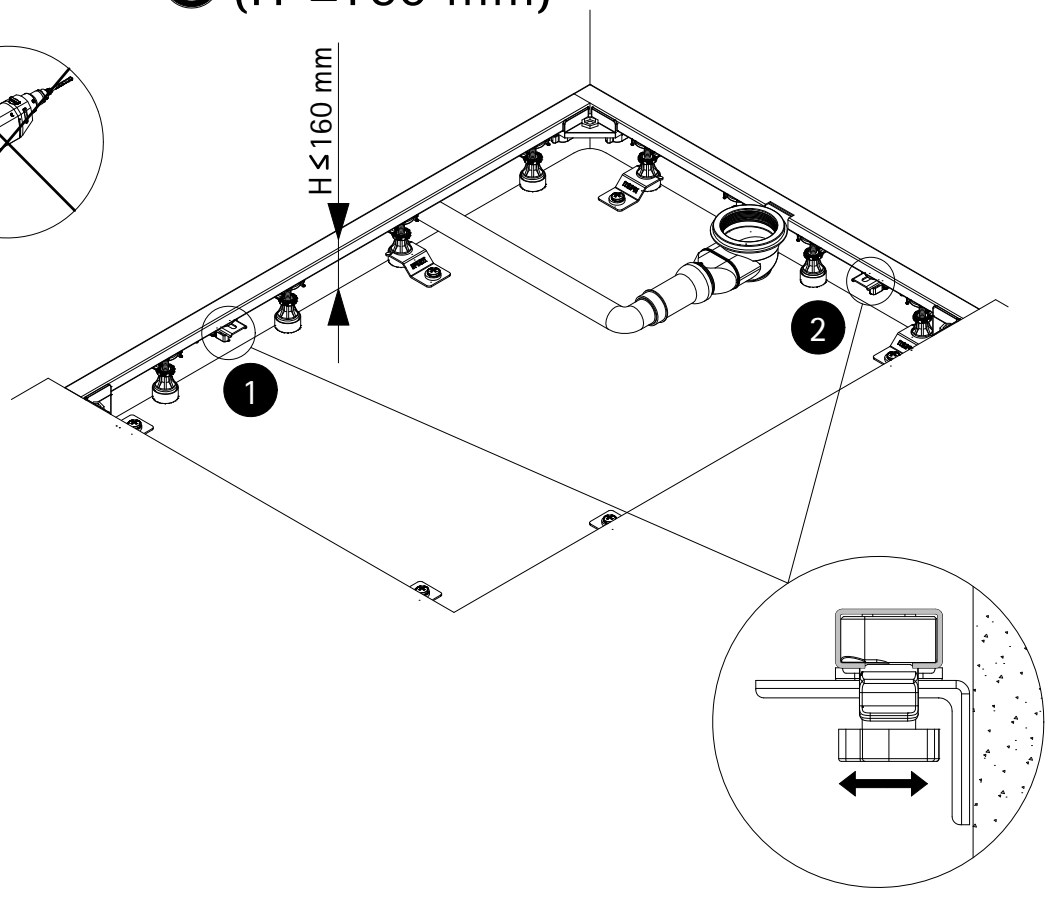
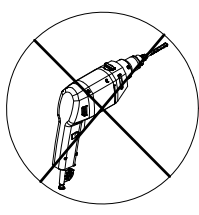

18

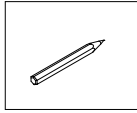

i ($H > 160$ mm)

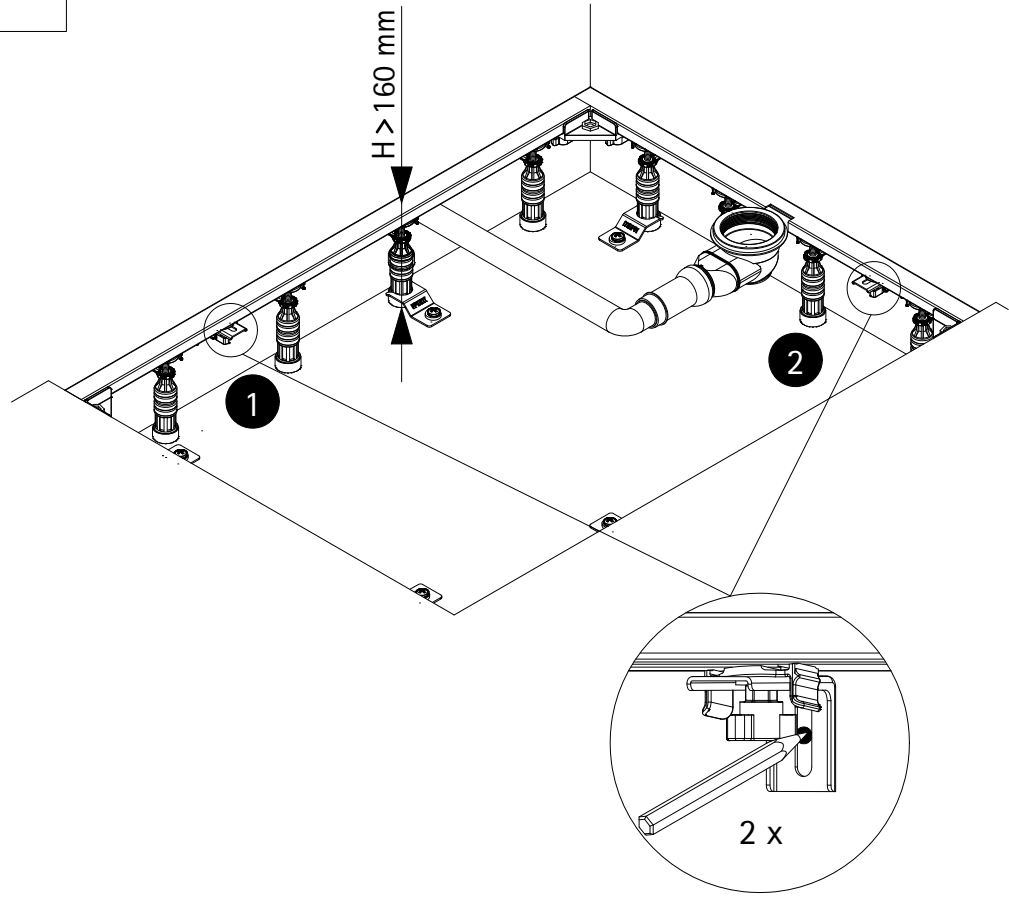

19

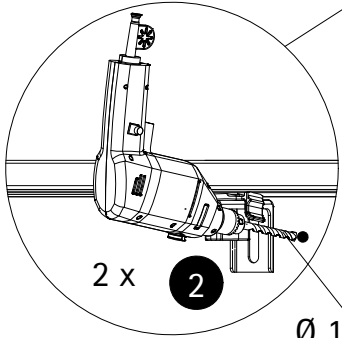
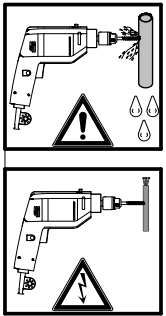
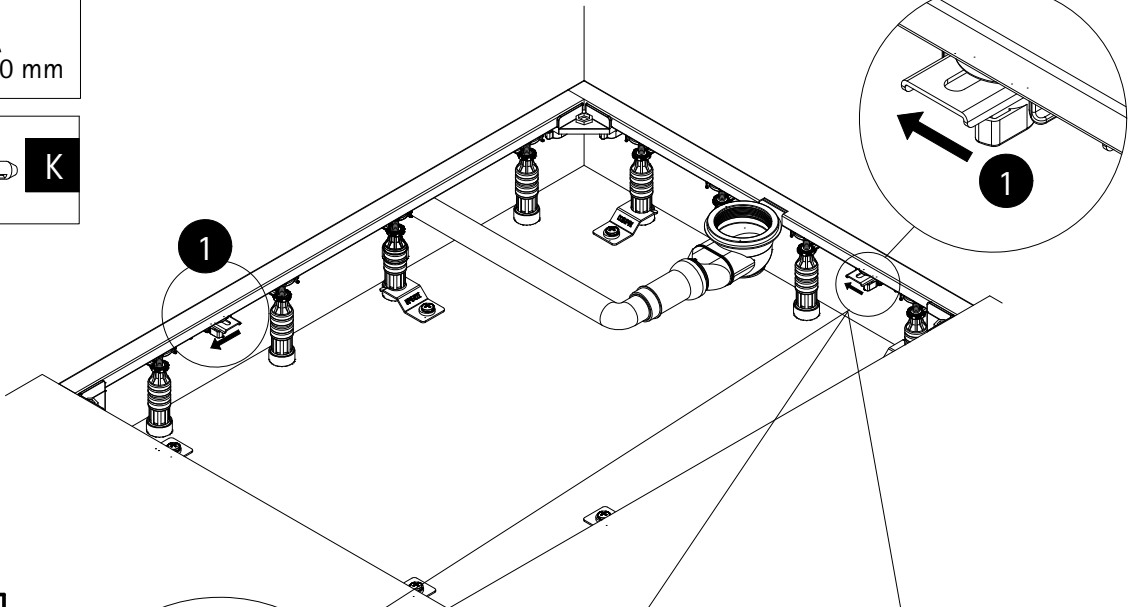
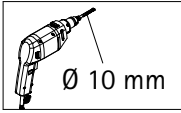

Ø 10 mm

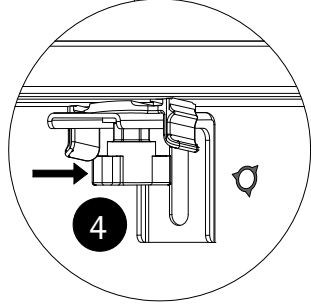
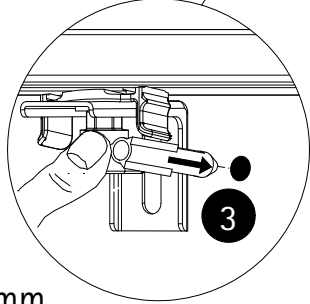

20

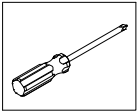

- de Ablauf fachgerecht anbringen und mit Wasser einen Dichtigkeitstest machen.
- en Install the waste professionally and do a leak test with water.
- fr Installer la bonde appropriée et faites un test d'étanchéité avec de l'eau.
- nl Afvoer vakkundig plaatsen en met water testen op dichtheid.

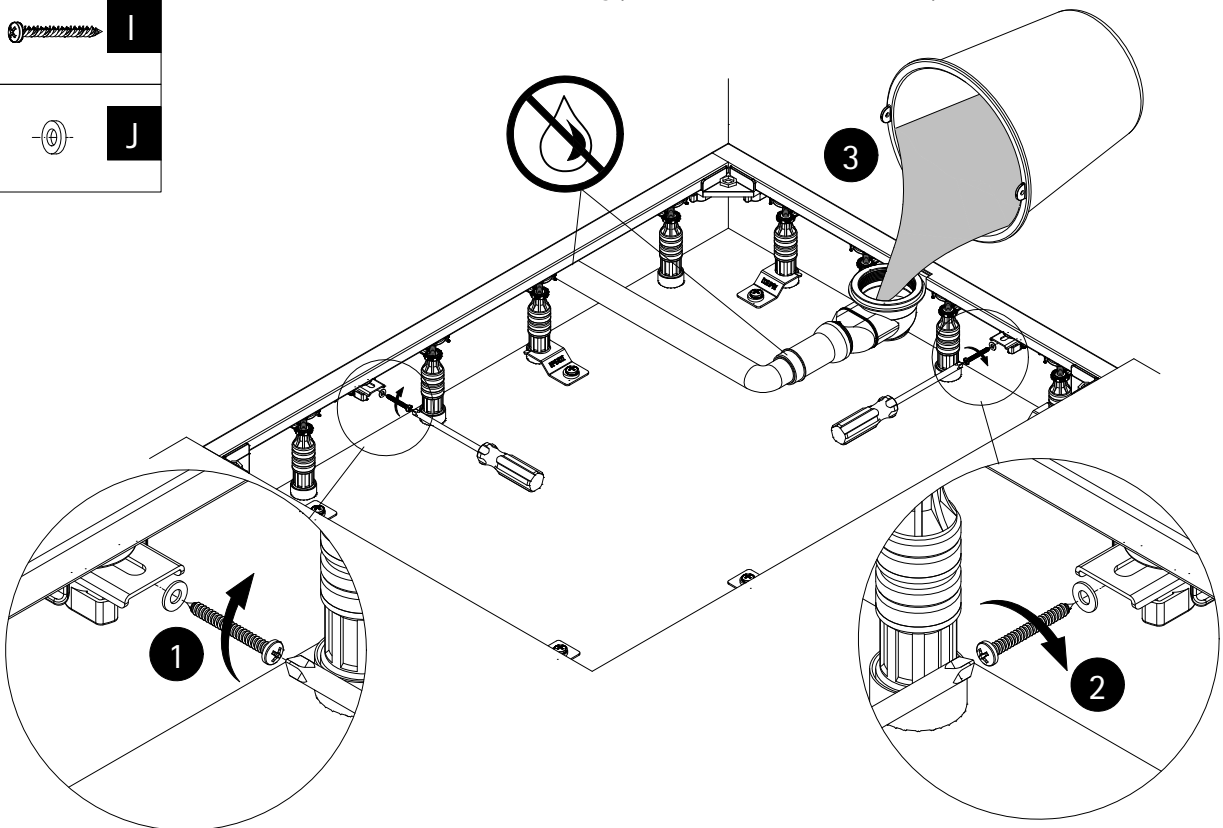
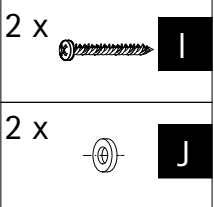

Info



- de** Bei bodengleichem Einbau, Abdichtung der Duschwanne sowohl zur Wand als auch zum angrenzenden Fussboden im Verbund fachgerecht ausführen!
- en** In the case of installation at floor level, seal the shower tray properly both to the wall and to the adjoining floor.
- fr** En cas de montage de plain-pied, étanchéifiez le receveur de douche aussi bien par rapport au mur que rapport au sol adjacent.
- nl** Bij installatie op vloerniveau moet de douchebak zowel aan de wand als aan de aangrenzende vloer goed en vakkundig worden afgedicht.

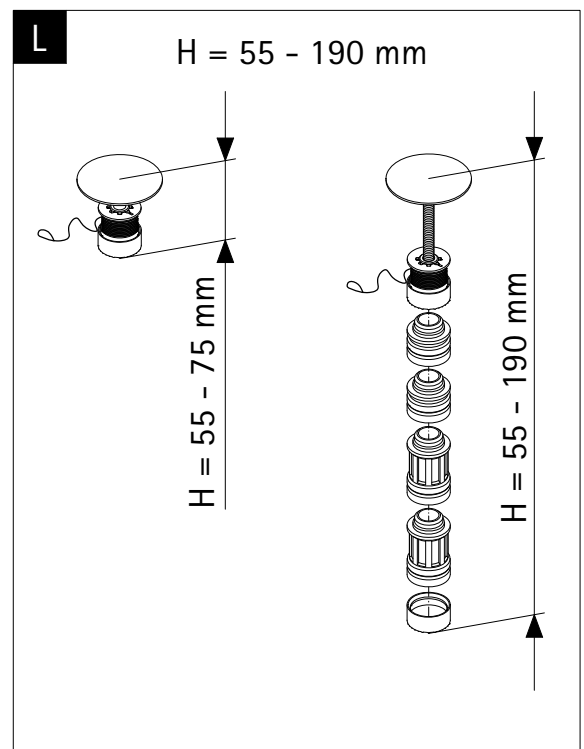
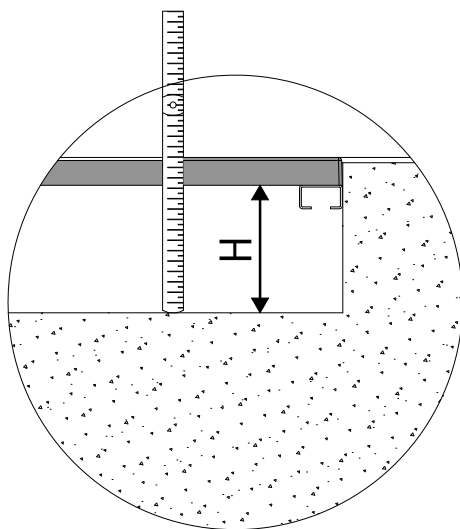
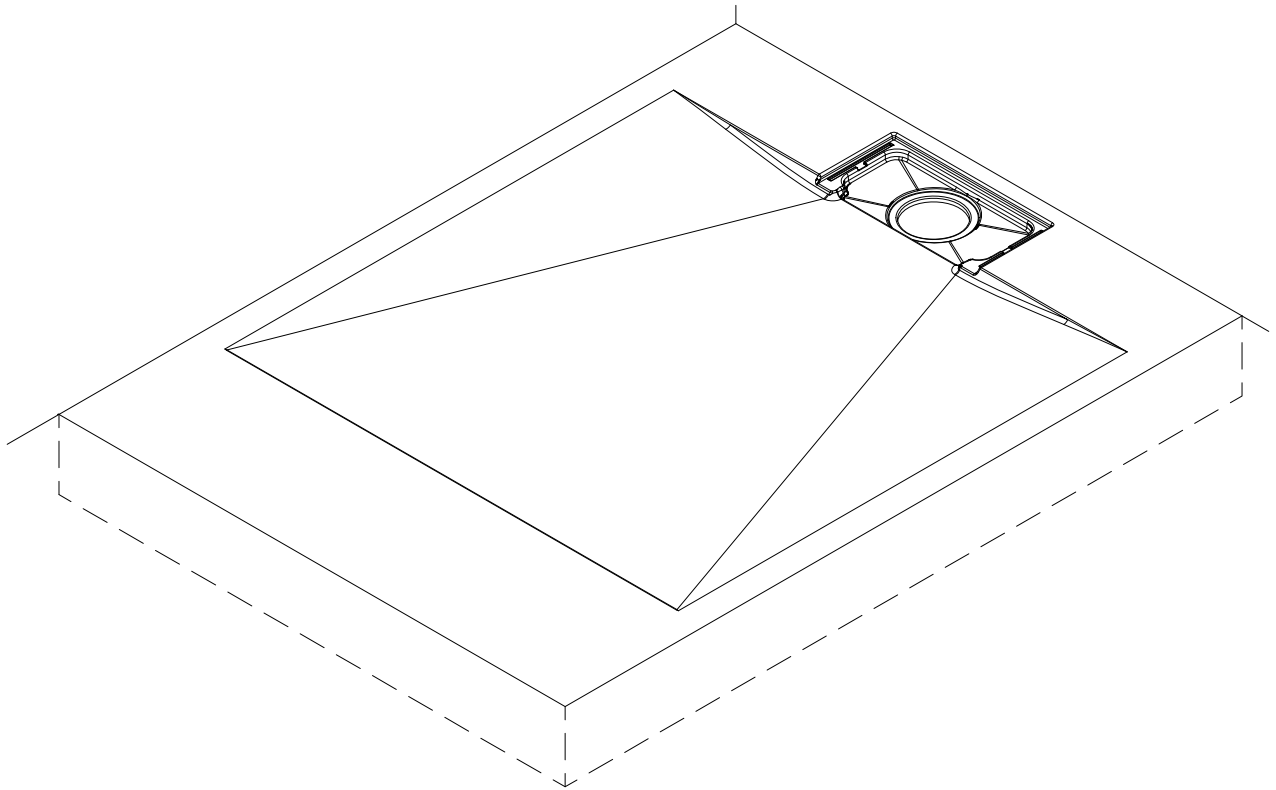

21

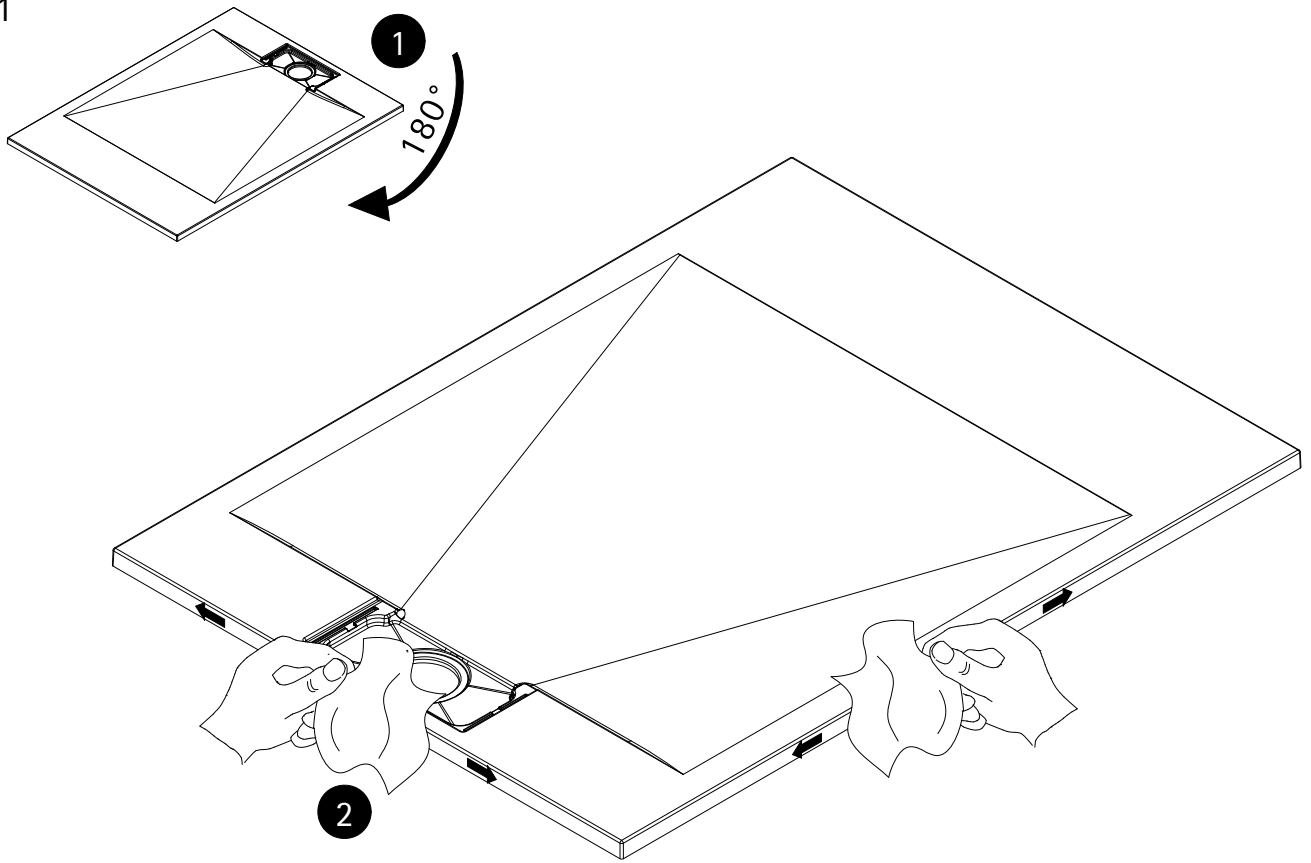

22

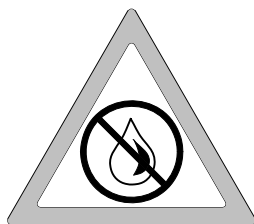
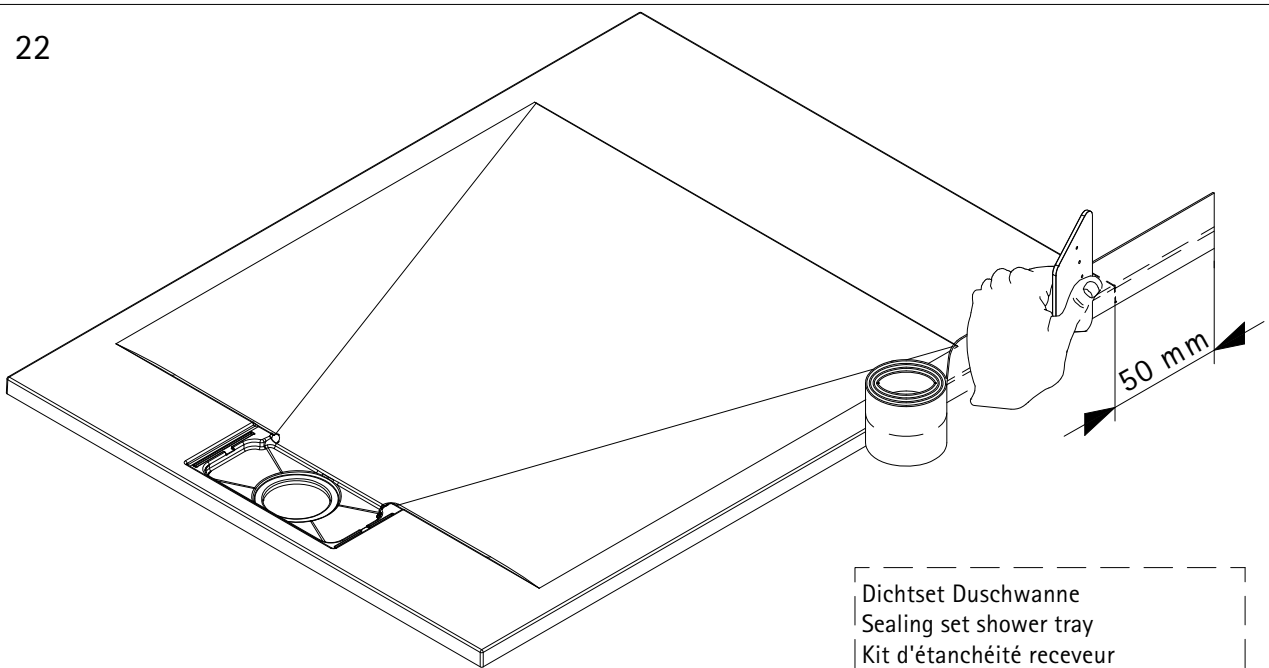

Dichtset Duschwanne
Sealing set shower tray
Kit d'étanchéité receveur
Dichtingsset douchebak

Optional lieferbar, optionally available, disponible en option, optioneel leverbaar

23

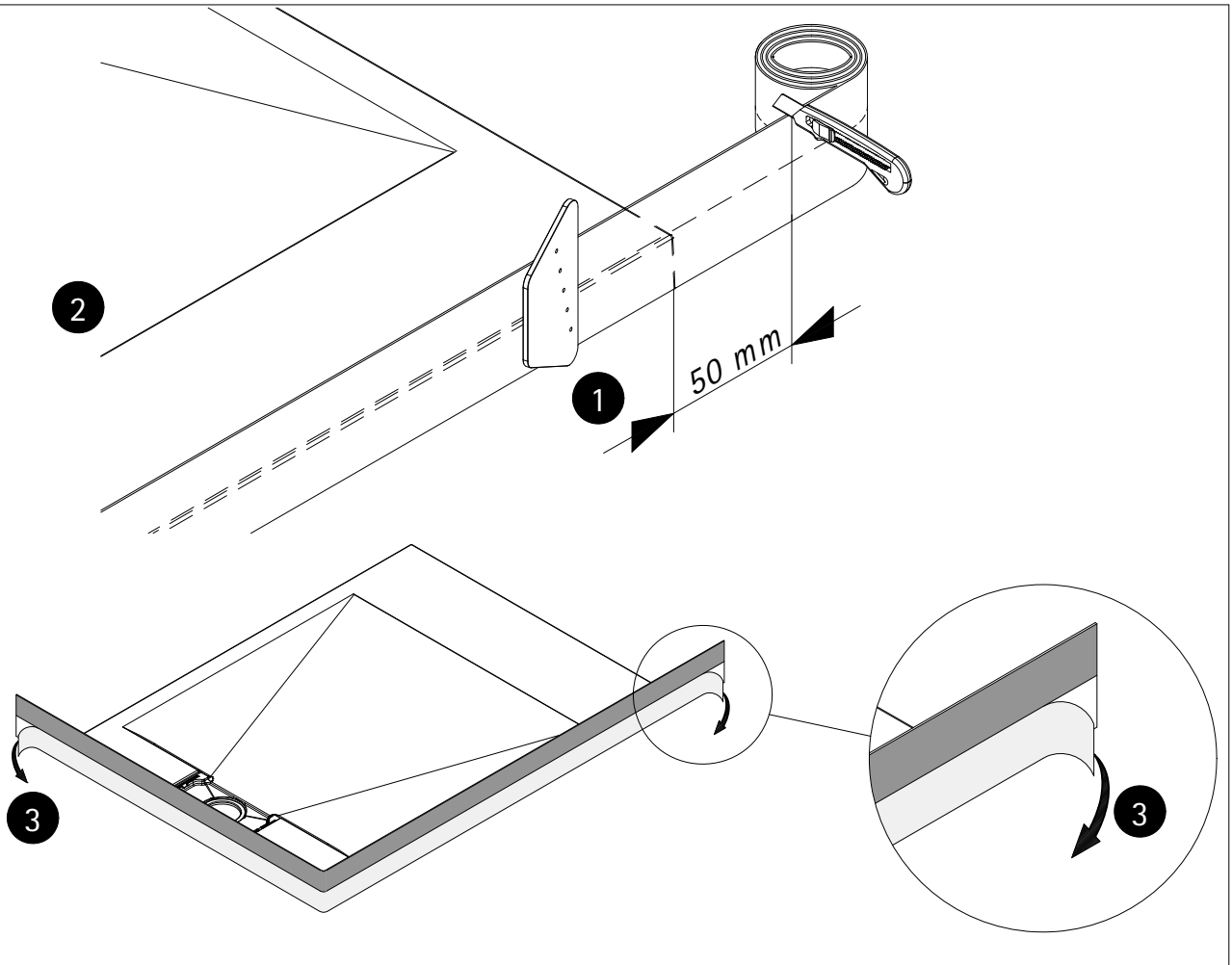

24

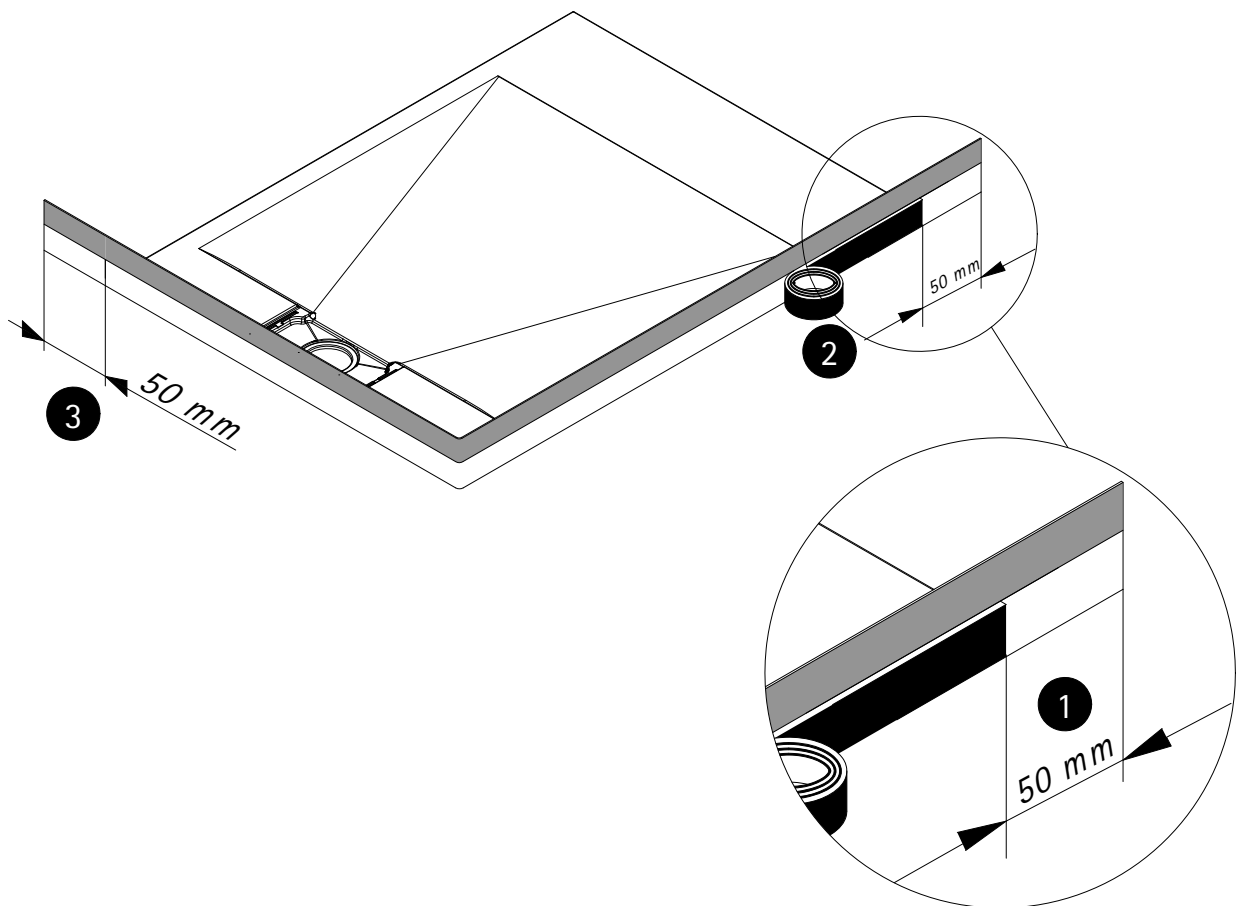

Optional lieferbar, optionally available, disponible en option, optioneel leverbaar

25

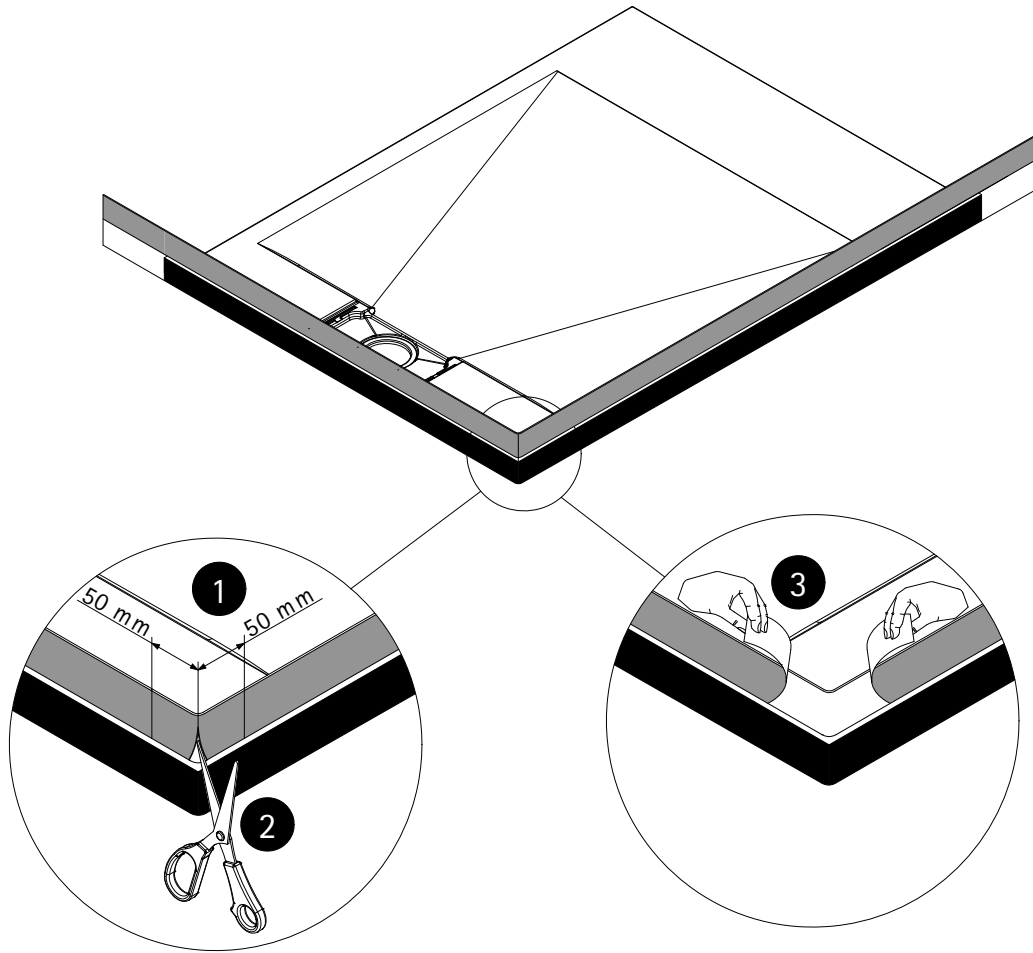

26

- de Dehnen des Wannendichtbandes in Ecke.
- en Stretch the shower tray sealing tape in the corner.
- fr Étirez la bande d'étanchéité du receveur dans le coin.
- nl De Afdichtingband in de hoek uitrekken.

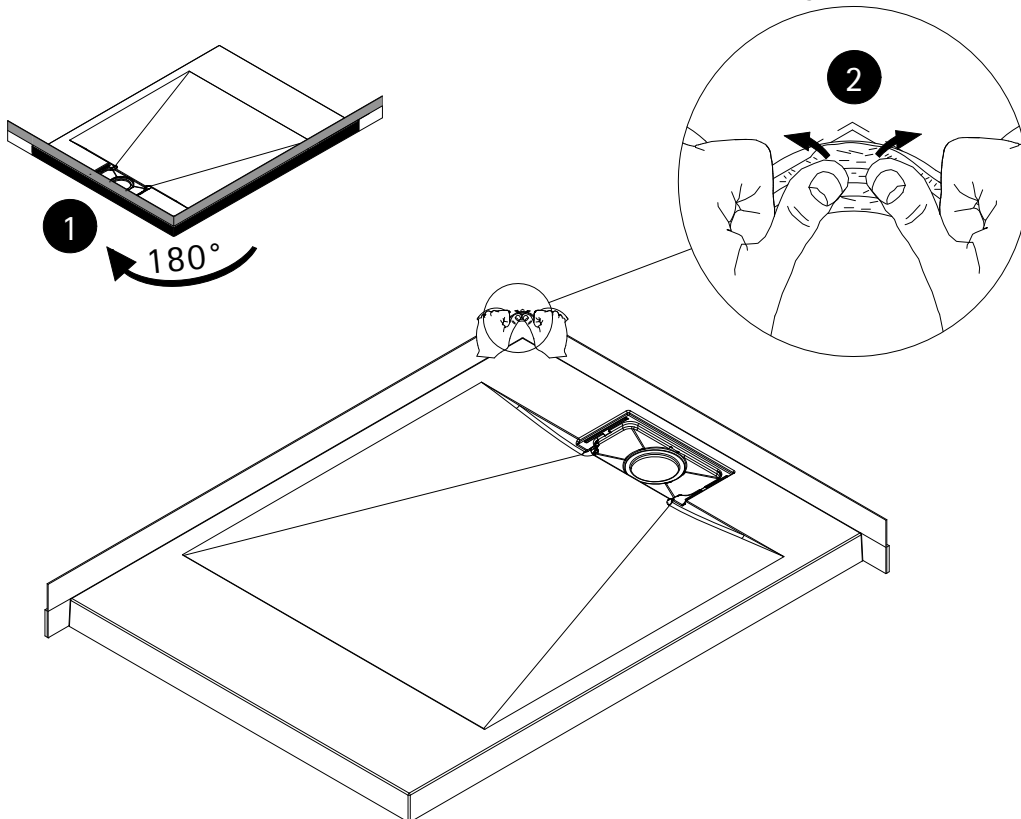

27

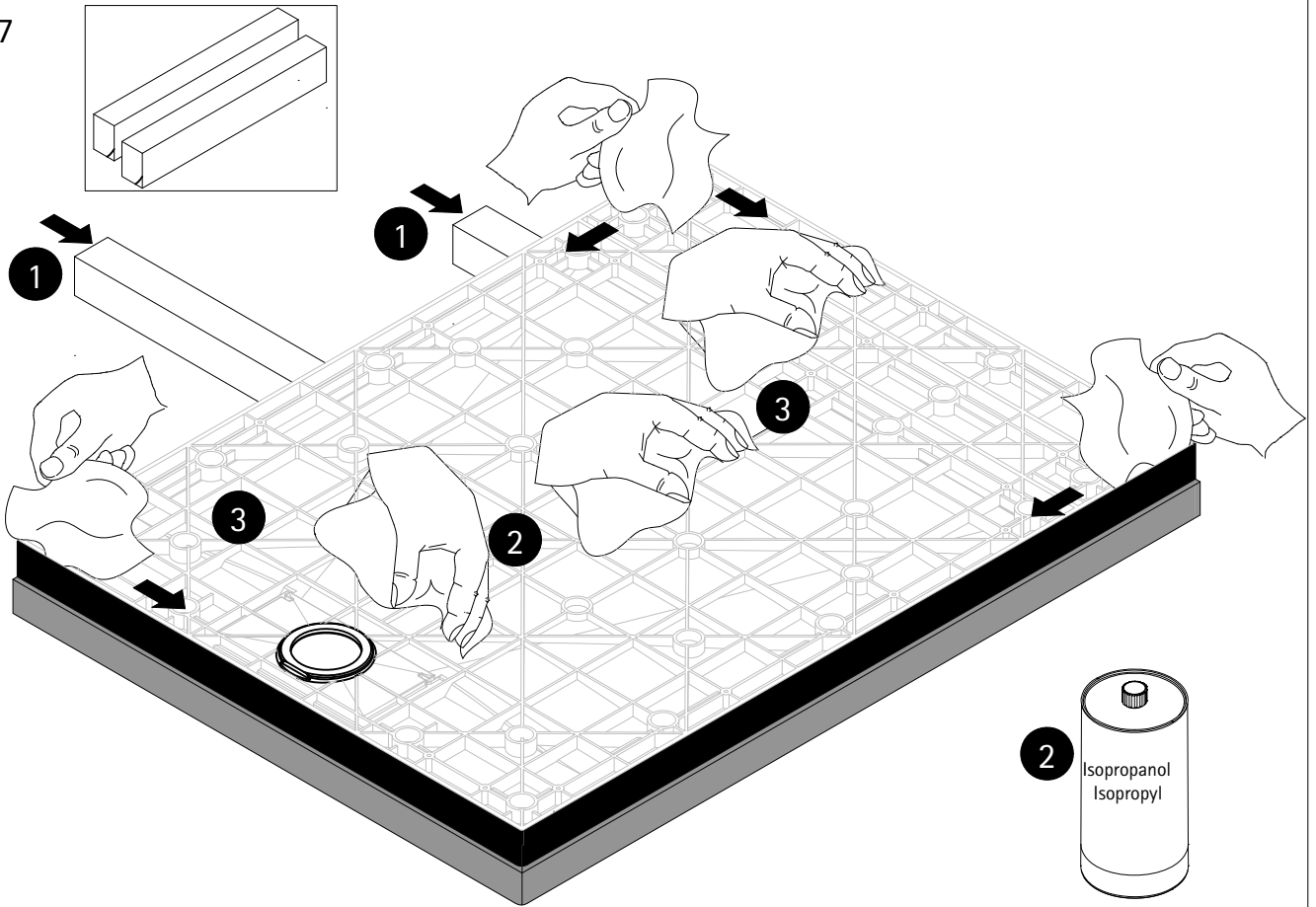

Info

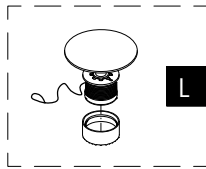

H = 55 mm
- 75 mm

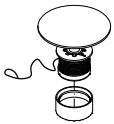

H = 76 mm
- 100 mm

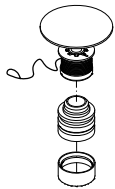

H = 101 mm
- 125 mm

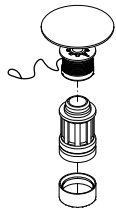

H = 126 mm
- 150 mm

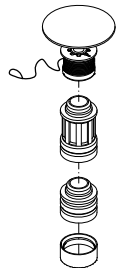

H = 151 mm
- 175 mm

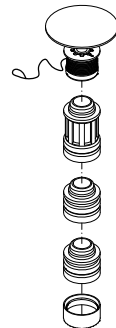

H = 176 mm
- 190 mm

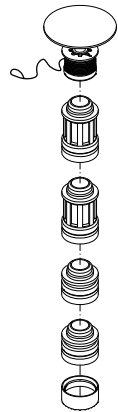

Info

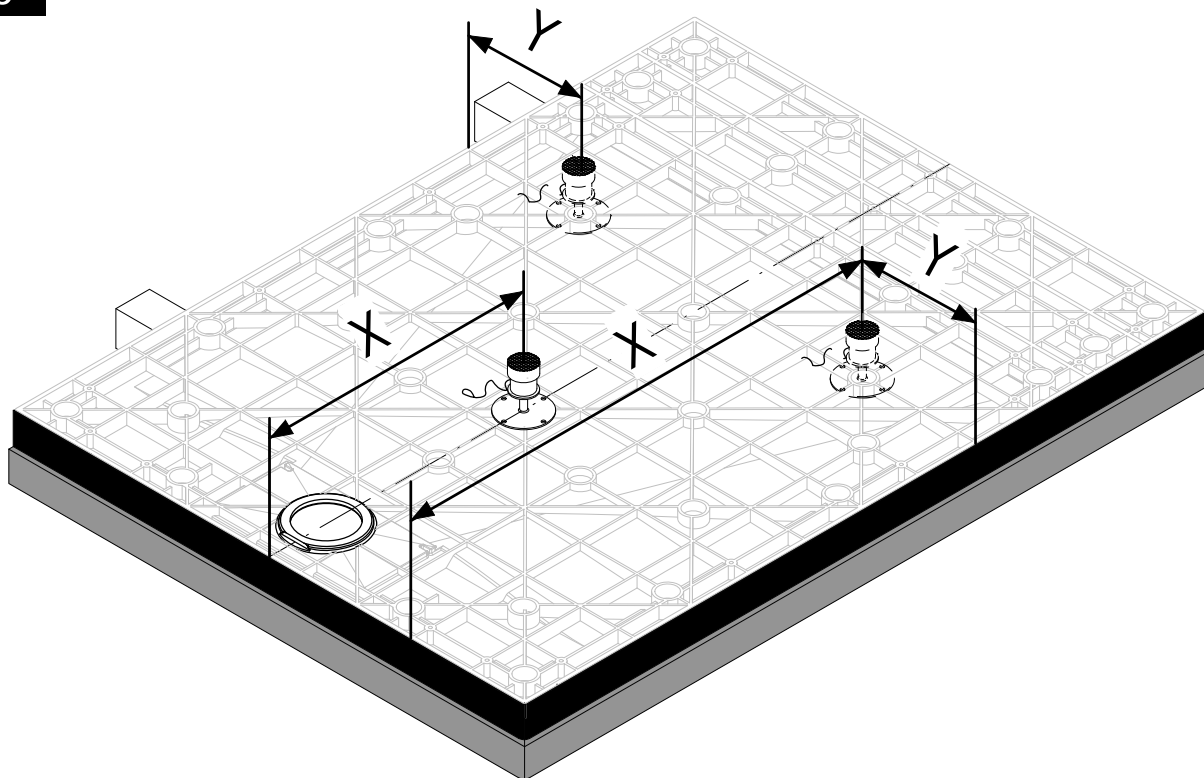

Info

Duschwannenmaß	Fuß 1		Fuß 2		Fuß 3	
	X	Y	X	Y	X	Y
700 x 1500 mm	300	350	650	350	950	350
700 x 1600 mm	300	350	950	350	1250	350
700 x 1700 mm	300	350	950	350	1250	350
800 x 800 mm	300	400	600	250	600	250
800 x 900 mm	300	400	600	250	600	250
800 x 1000 mm	300	400	600	250	600	250
800 x 1200 mm	400	400	700	400	1000	400
800 x 1400 mm	400	400	700	400	1000	400
800 x 1600 mm	400	400	700	400	1300	400
900 x 900 mm	300	450	600	200	600	200
900 x 1000 mm	300	450	600	300	600	300
900 x 1200 mm	450	450	955	300	955	300
900 x 1400 mm	450	450	750	450	1005	450
900 x 1600 mm	450	450	755	450	1350	450

28

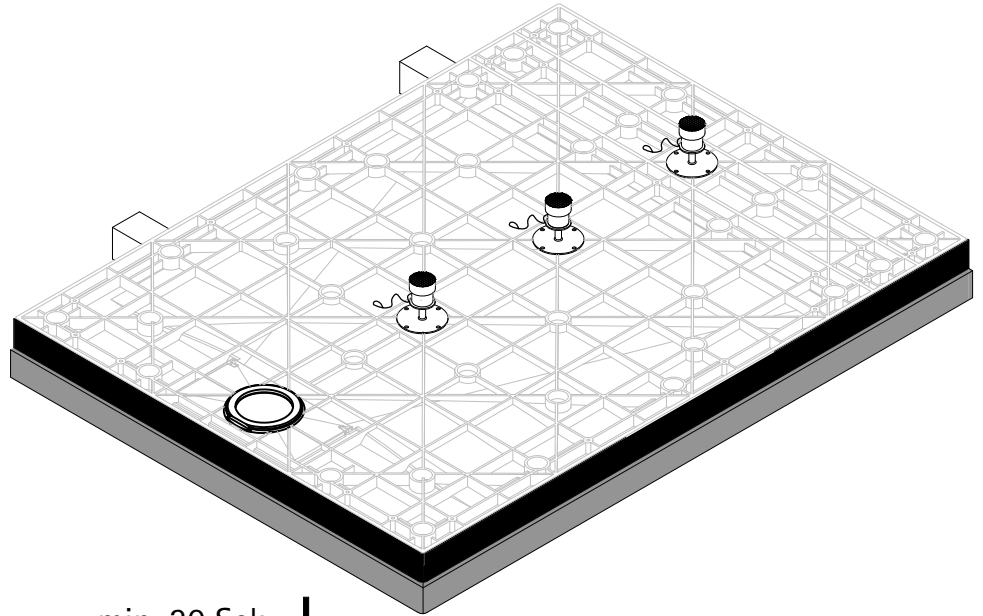
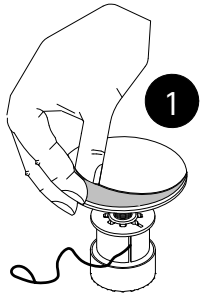

min. 20 Sek. ↓

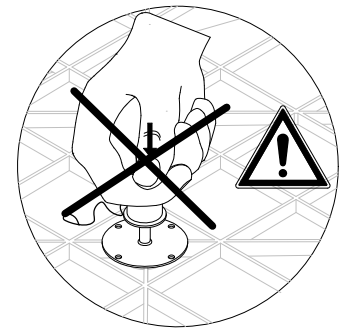
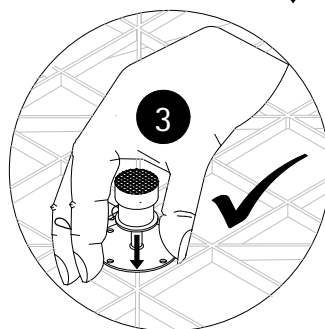
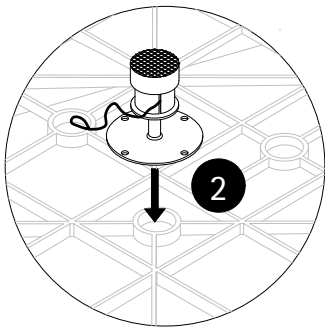

29

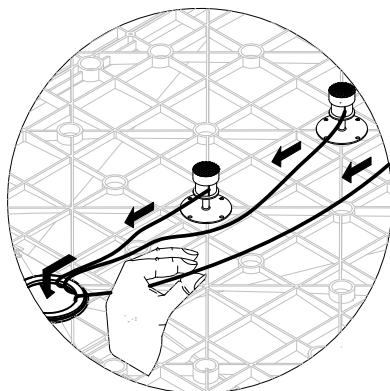
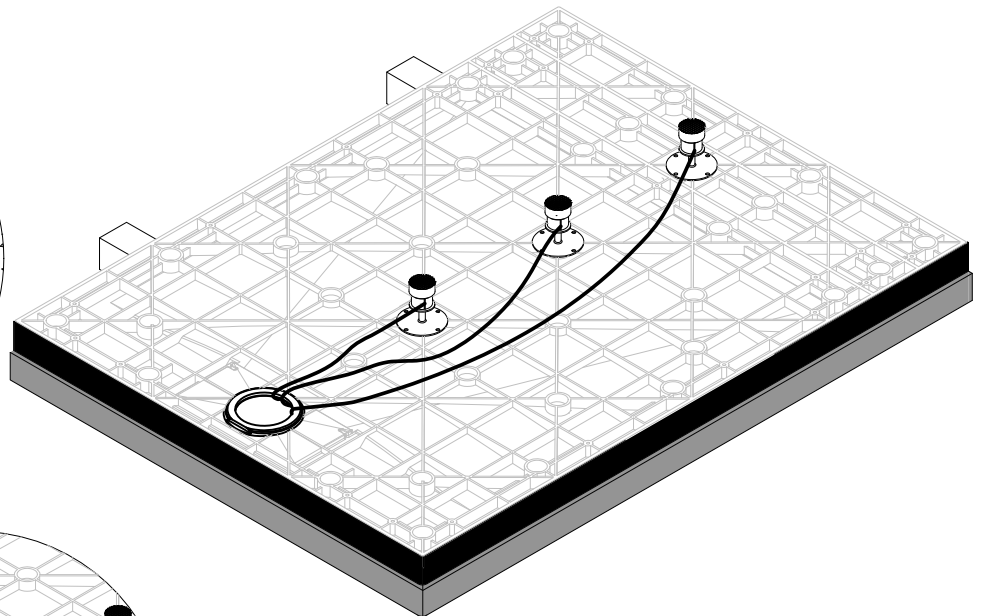
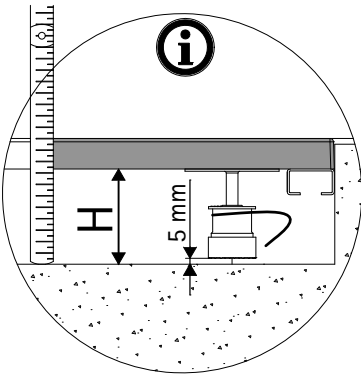

32

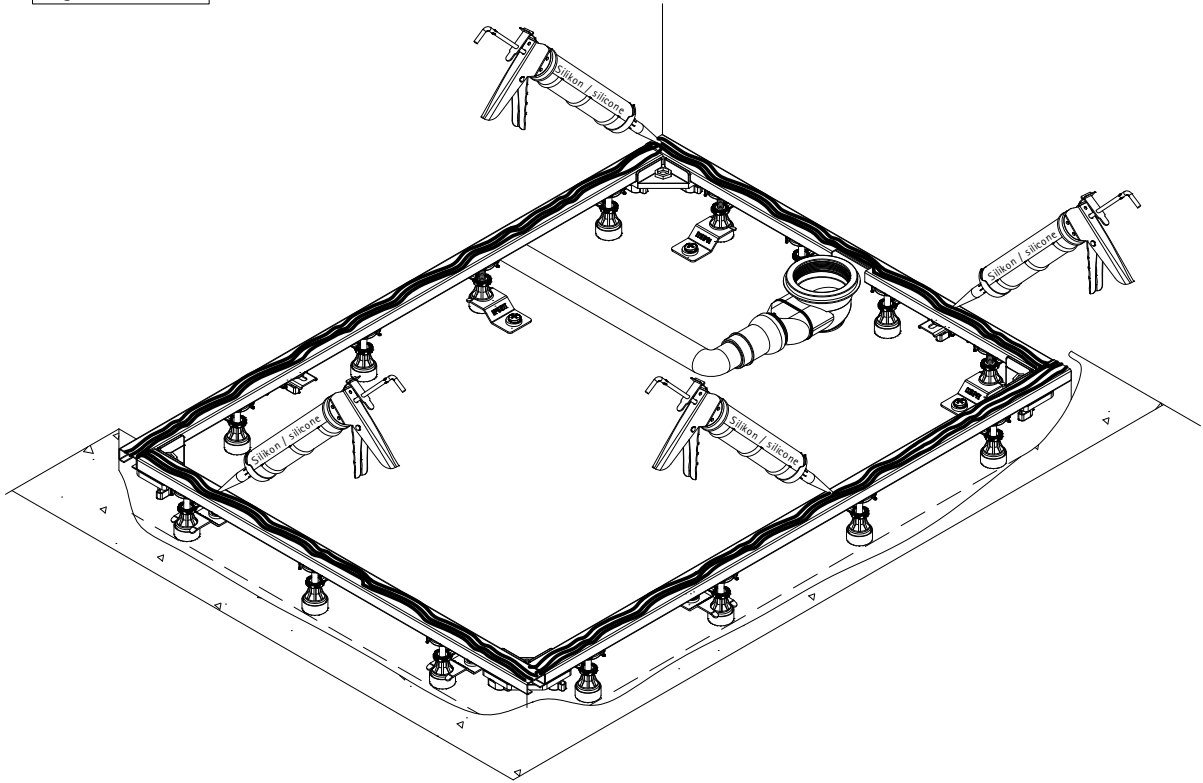
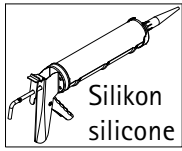

33

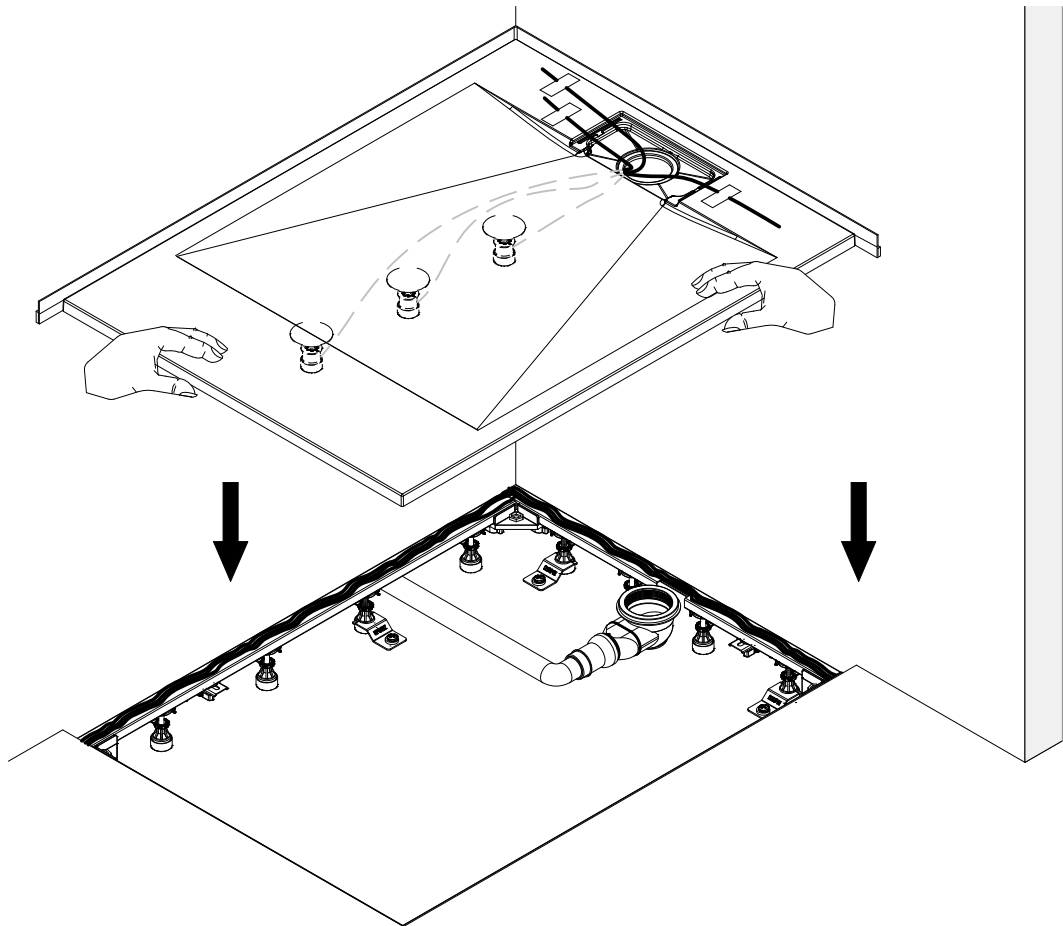

34

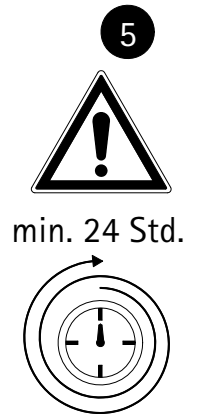
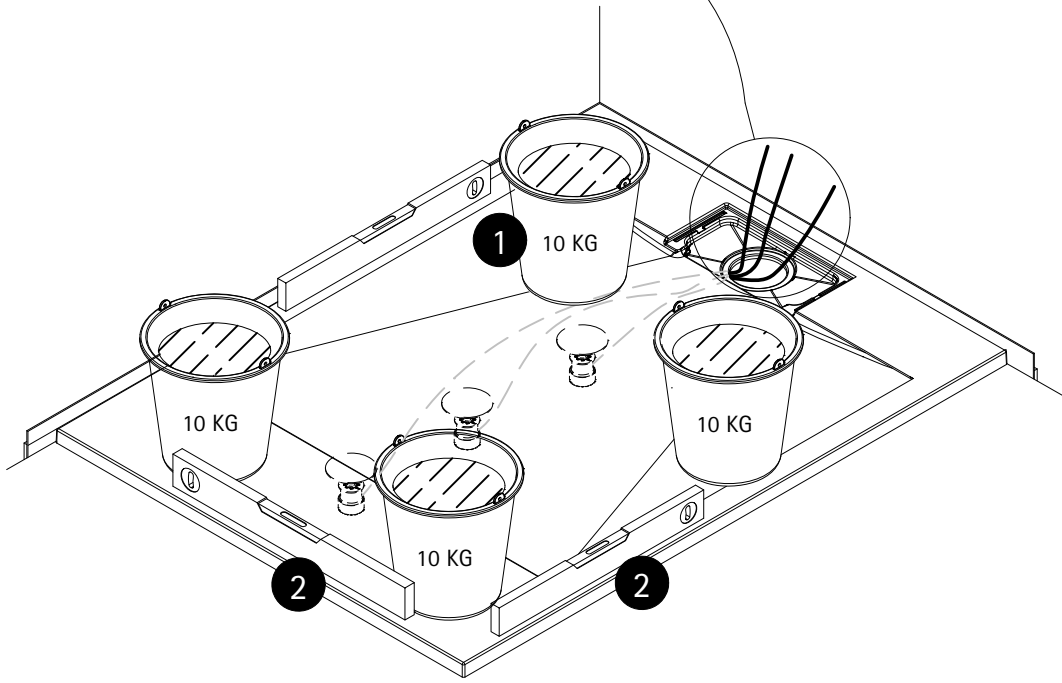
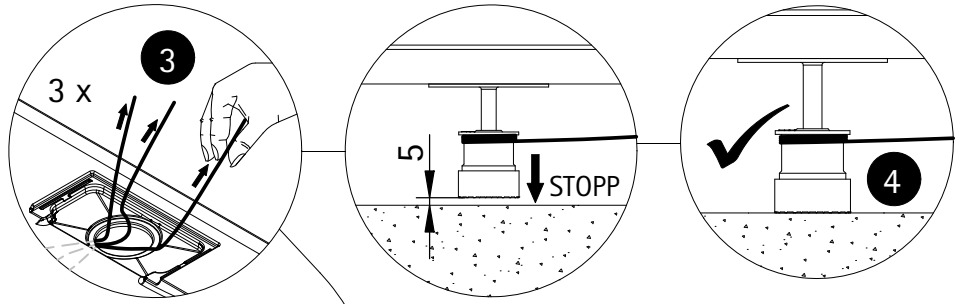
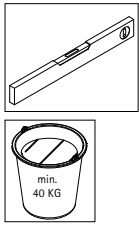

35

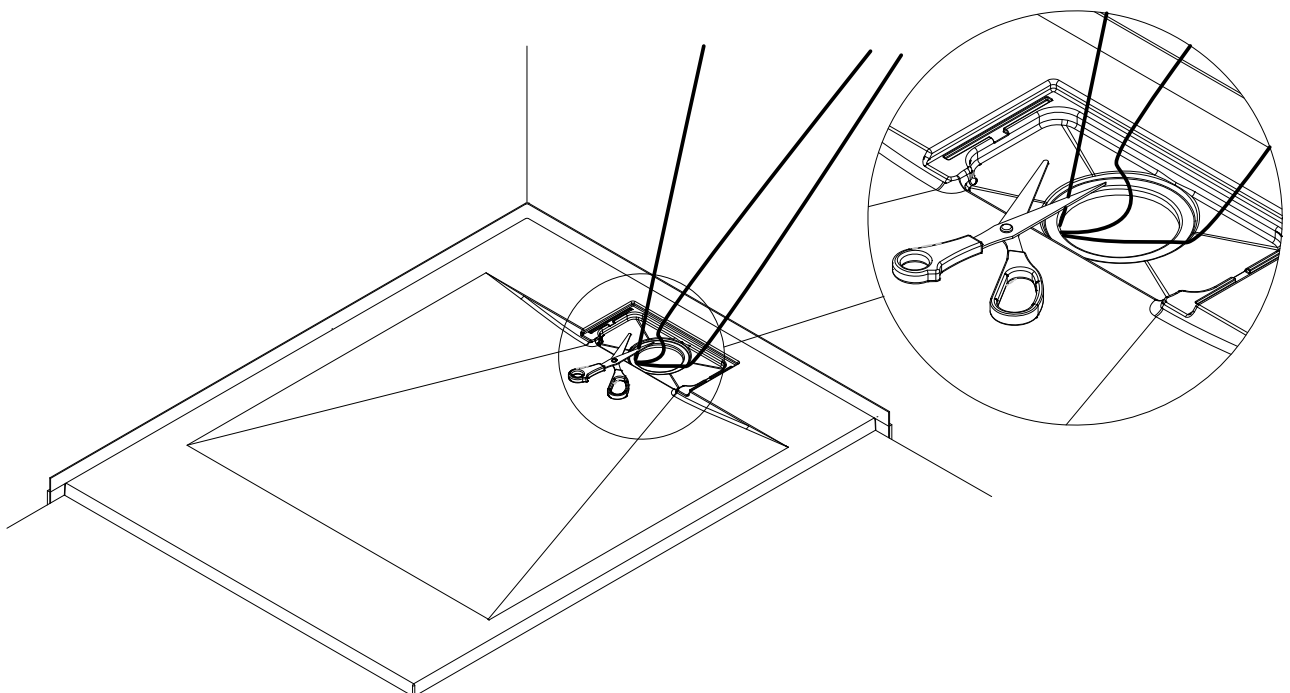
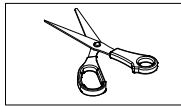

36

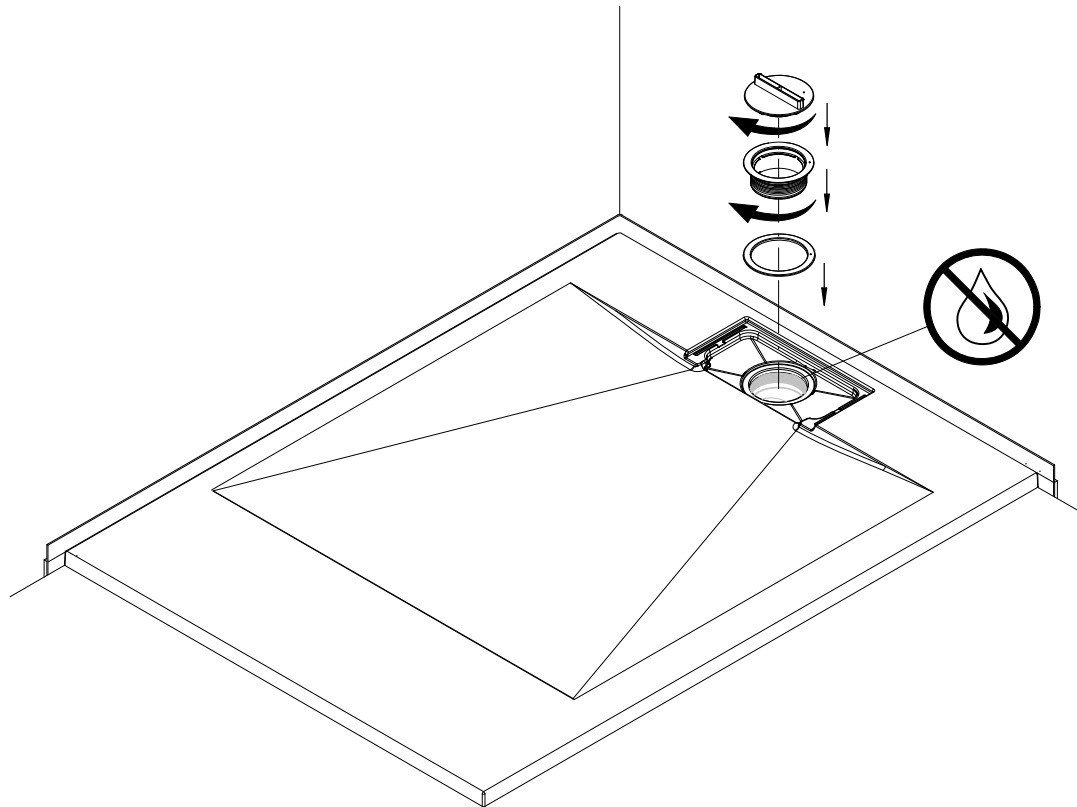

Optional lieferbar, optionally available, disponible en option, optioneel leverbaar

37

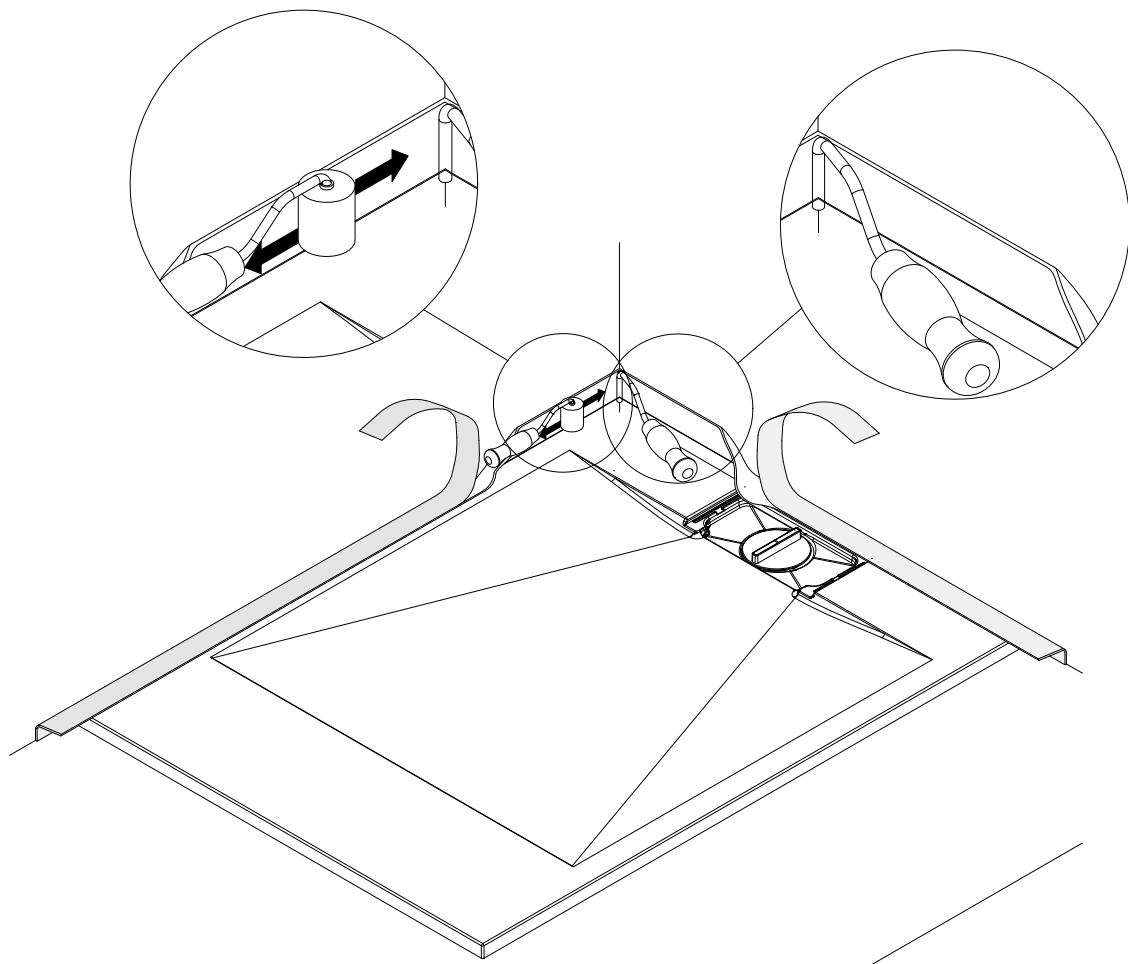

38

* Nicht im Lieferumfang enthalten.
not included in delivery.
non fourni gans l'emballage.
niet bij levering inbegrepen.

- Verbundabdichtung
- Composite sealing
- Étanchéité composite
- Composiet waterdicht maken

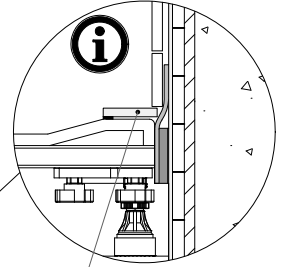

Distanzband
Distance band
Bande d'espacement
Afstandsband

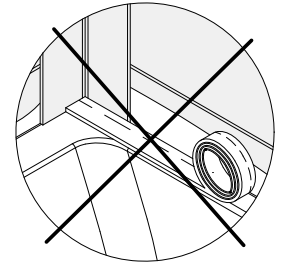
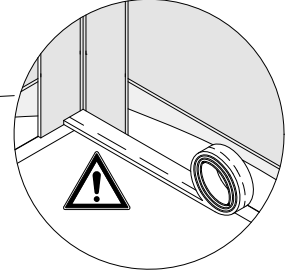

Distanzband
Distance band
Bande d'espacement
Afstandsband

Optional lieferbar, optionally available, disponible en option, optioneel leverbaar

39

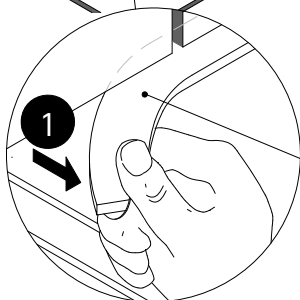
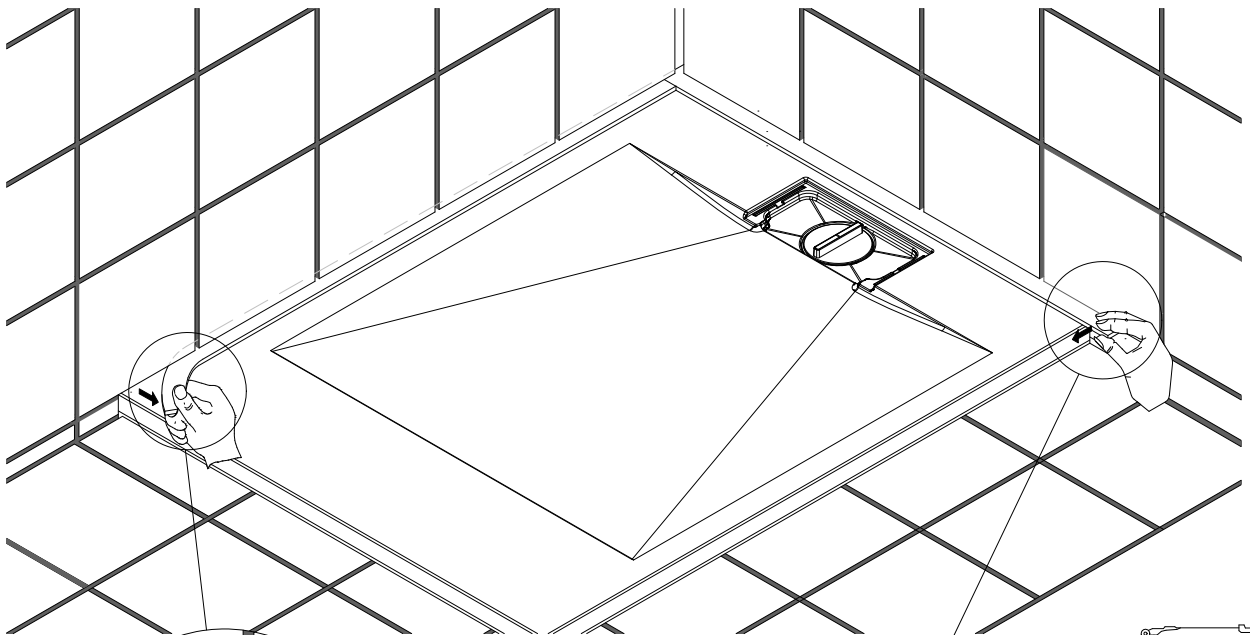

Distanzband
Distance band
Bande d'espacement
Afstandsband

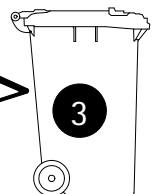
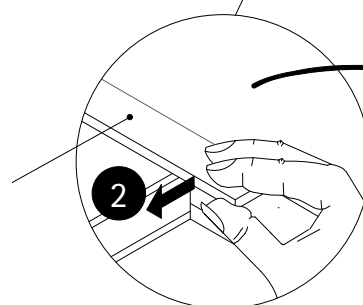

Optional lieferbar, optionally available, disponible en option, optioneel leverbaar

40

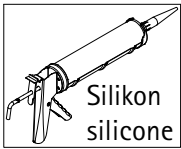

Silikon
silicone

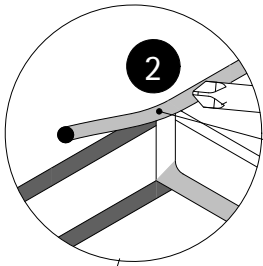

2

* Nicht im Lieferumfang enthalten.
not included in delivery.
non fourni dans l'emballage.
niet bij levering inbegrepen.

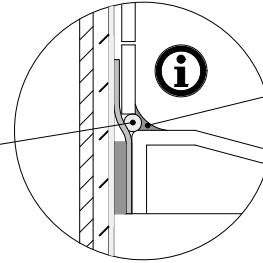

i

Silikon
silicone



- de Dichtschnur anbringen.
- en Insert sealing cord.
- fr Mettez en place le cordon d'étanchéité.
- nl Breng afdichtingskoord ann.

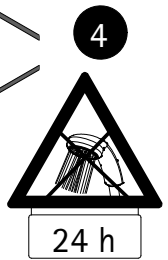
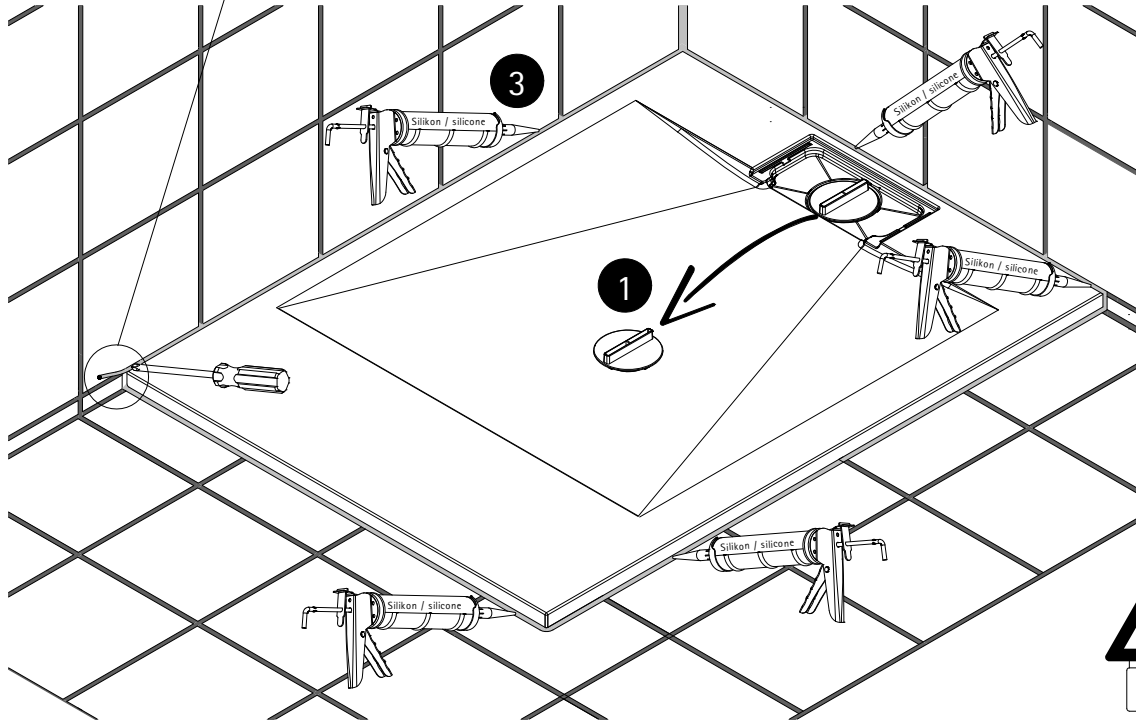

41

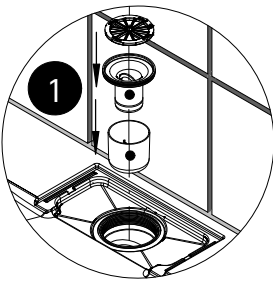

1



de Vor Erstbenutzung reinigen

en Clean before first use



fr Veuillez nettoyer avant la première utilisation

nl Vóór het eerste gebruik a.u.b. reinigen

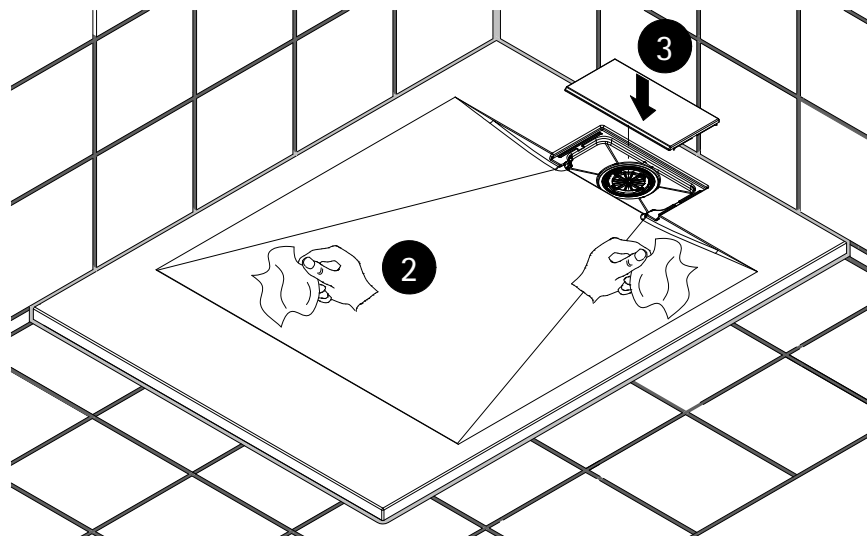

2

3

Optional lieferbar,
optionally available,
disponible en option,
optioneel leverbaar



3

de Eine regelmäßige Reinigung im Ablaufbereich unter der Ablaufabdeckung wird empfohlen.

en Regular cleaning in the drain area under the drain cover is recommended!

fr Un nettoyage régulier dans la zone d'écoulement sous le couvercle d'écoulement est recommandé!

nl Regelmatige reiniging van het afvoergebied onder het putdeksel wordt aanbevolen!

7000-1

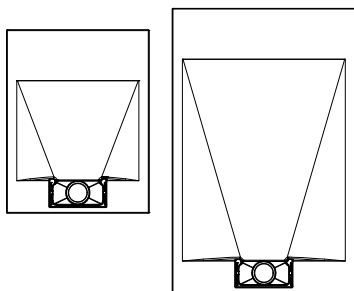

Technische Hilfe / technical help / l'aide technique / technologische ondersteuning
Ersatzteilbestellung / spare parts order
commande de pièces détachées / Bestelling van onderdelen:
Telefon 02631 / 8607-0



E-Mail: info@duschkabine.com



Dusch-Info
August-Horch-Straße 1
56566 Neuwied
Deutschland / Germany / Allemagne / Duitsland

