



Montageanleitung

Installation instructions

Instructions de montage

Montagehandleiding

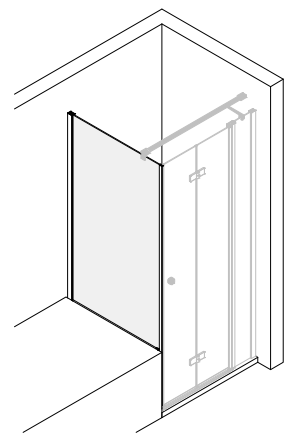
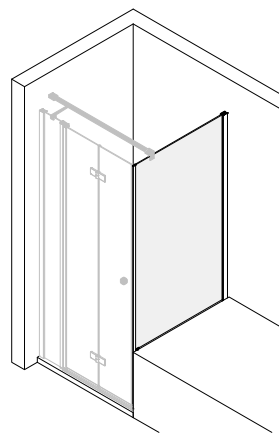
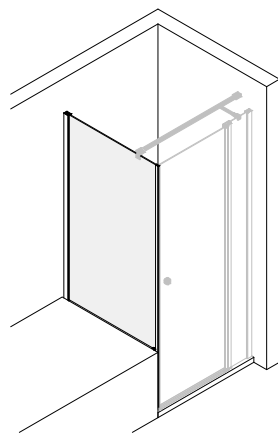
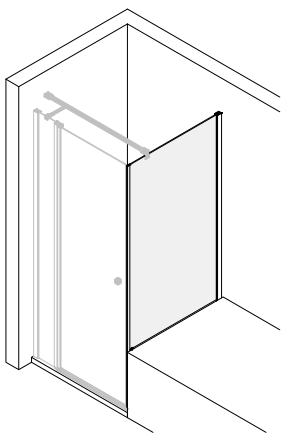
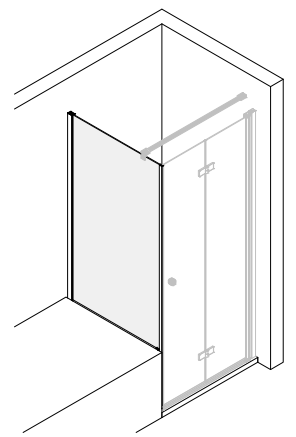
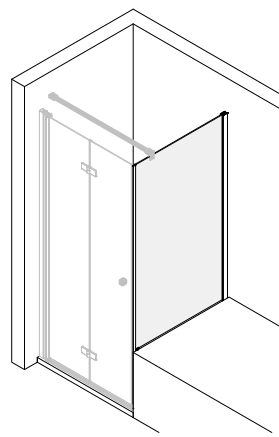
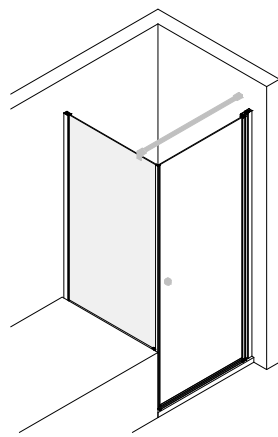
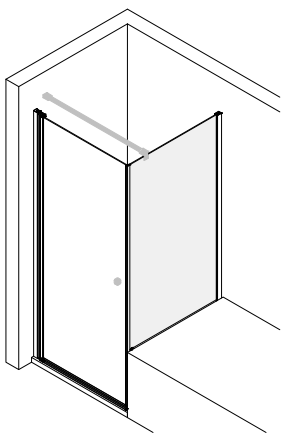



SICHERHEITSHINWEISE / SAFETY INSTRUCTIONS CONSEILS DE SÉCURITÉ / VEILIGHEIDSAANWIJZINGEN



de Glaskanten schützen

en Protect glass edges

fr Protégez les bords du verre

nl Glasranden beschermen



de Schutzbrille tragen

en Wear safety goggles

fr Portez des lunettes de protection

nl Veiligheidsbril dragen

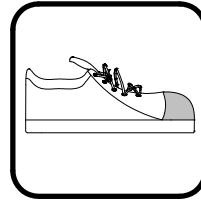

de Sicherheitsschuhe tragen

en Wear safety shoes

fr Portez des chaussures de sécurité

nl Veiligheidsschoenen dragen

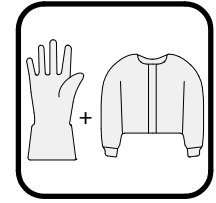

de Lange Handschuhe und langärmelige Kleidung tragen

en wear long gloves and long-sleeved clothing

fr portez des gants longs et des vêtements à manches longues

nl Draag lange handschoenen en kleding met lange mouwen

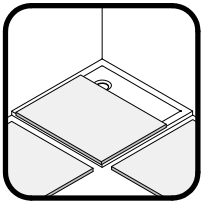

de Decken im Arbeitsbereich und dessen Umfeld auslegen

en Cover the shower tray and its area completely

fr Couvrez complètement le bac de douche et ses environs

nl Dekens op de douchebak en de omgeving leggen

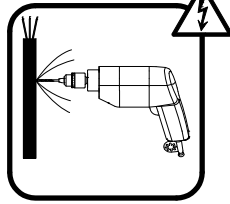

de über die Lage der Stromleitung informieren

en get information about the location of the power line

fr Informez-vous sur l'emplacement de la ligne électrique

nl Informeren over de locatie van de hoogspanningslijn

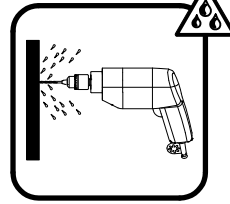

de über die Lage der Wasserleitung informieren

en get information about the location of the water pipe

fr Informez-vous sur l'emplacement de la ligne d'eau

nl Informeren over de locatie van de waterleiding

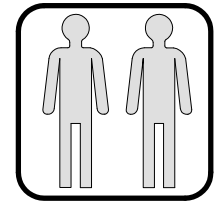

de Empfohlene Montage mit 2 Personen.

en Assembly recommended with 2 persons

fr Montage recommandé avec 2 personnes

nl Aanbevolen montage met 2 personen

MAßE / DIMENSIONS / DIMENSIONS / AFMETINGEN

- de Prüfen, ob die gemessenen Maße innerhalb der Tabellenwerte (A) liegen, damit die Duschkabine problemlos, anhand der Montageanleitung aufgebaut werden kann.
- en Check whether the measured dimensions are within the table values (A), so that the shower enclosure can be assembled without any problems using the assembly instructions.
- fr Vérifier que les dimensions mesurées se situent dans les valeurs du tableau (A), afin que la cabine de douche puisse être montée sans problèmes selon les instructions de montage.
- nl Controleer of de gemeten afmetingen binnen de tabelwaarden (A) vallen, zodat de douchewand zonder problemen met behulp van de montagehandleiding kan worden gemonteerd.

de Montage auf Duschwanne

(Maße des installierten Duscheckens)

en Mounting on shower tray

(Dimensions of the installed tray)

fr Montage sur receveur de douche

(Dimensions du mur au bord extérieur du receveur)

nl Montage op douchebak

(Afmetingen van de ingebouwde douchebak)

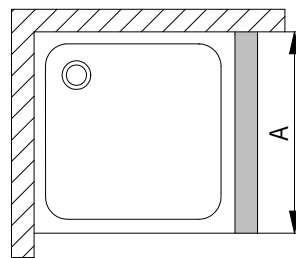

Badewanne / bath tub/
baignoire / badkuip

A (Seitenwandseite / side of side panel /
côté paroi / zijwand zijde)

750 mm

730 - 750 mm

800 mm

780 - 800 mm

900 mm

880 - 900 mm

de Die Aufstellfläche der Duschkabine muss eben sein.

en The installation surface of the shower enclosure must be level.

fr La surface d'installation de la cabine de douche doit être plane.

nl Het montagevlak van de douchewand moet waterpas zijn.

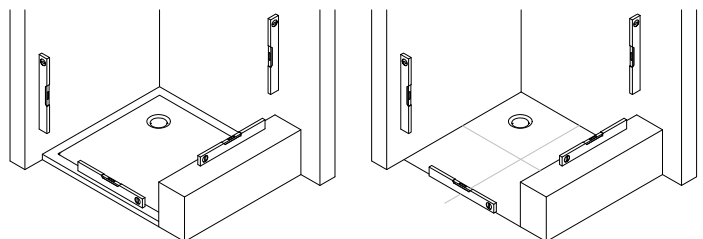

AUFBAUART / ASSEMBLY SITUATION / TYPE DE MONTAGE / ASSEMBLAGE SITUATIE

- de** Bei der Montage der Duschkabine gibt es zwei Aufbauarten: Aufbau **a** und **b**
In dieser Montageanleitung wird der Aufbau **a** dargestellt. Die Montageschritte für den Aufbau **b** sind spiegelbildlich durchzuführen.
- en** There are two types of installation for the shower enclosure: **a** and **b**
Situation **a** is described in this assembly instruction. The assembly steps for situation **b** must be carried out in mirror image.
- fr** Il y a 2 possibilités de monter la paroi de douche : **a** et **b**
La version **a** est illustrée dans la notice de montage. Les étapes pour monter la version **b** sont inversées.
- nl** Er zijn twee soorten installatie voor de douchewand: **a** en **b**
Montage **a** wordt getoond in deze montagehandleiding. De montageschappen voor installatie **b** moeten in spiegelbeeld worden uitgevoerd.

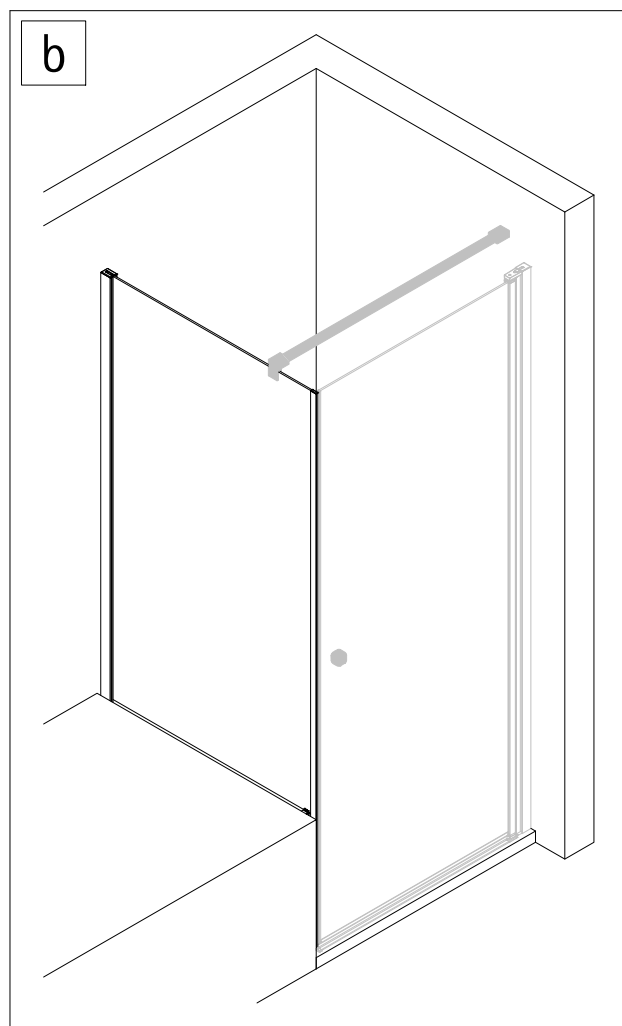
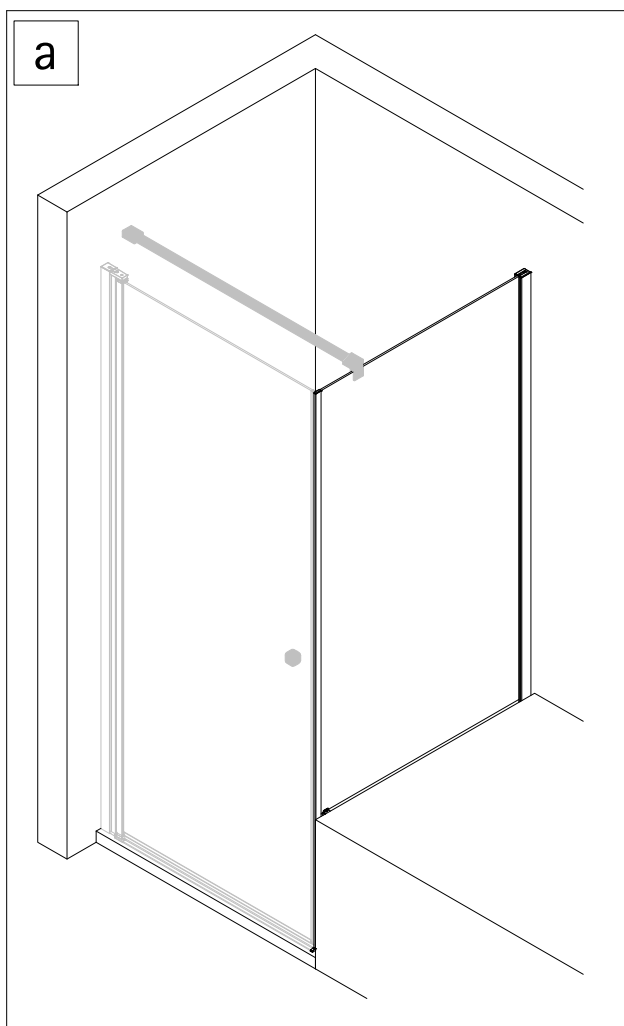

verkürzte Seitenwand neben Wanne

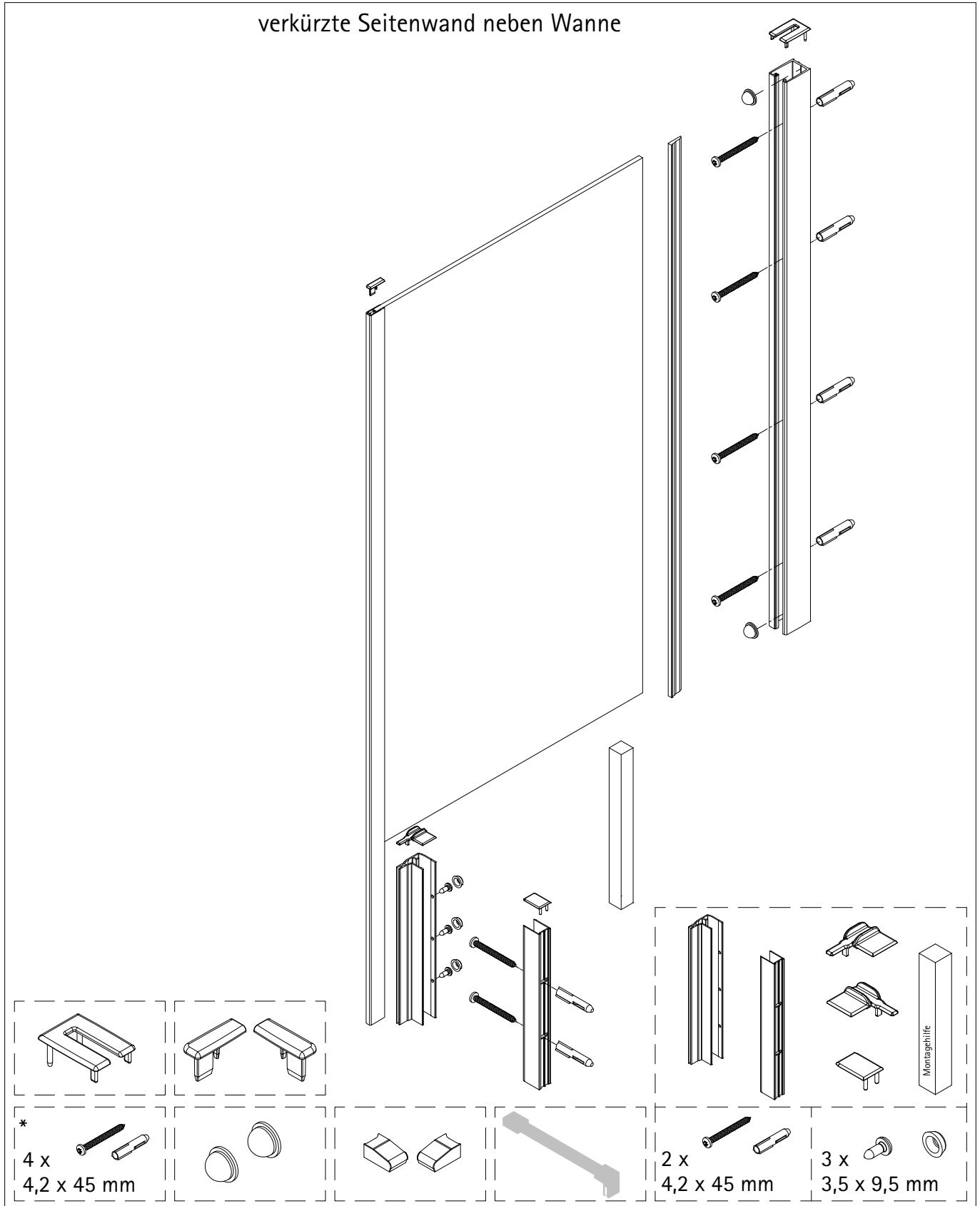

*

de Dieser universelle Schraubenbeutel wird für verschiedene Arten von Duschtrennungen eingesetzt. Die eventuell überzähligen Teile sind deshalb nicht Fehler Ihres Montagevorganges. Wir bitten um Ihr Verständnis.

en This is a universal set of screws, which is used for various of our shower screens models. It can occur that you will have more parts in this packet than you need for the assembly of your model. Consequently, if you have parts left, it does not mean that you have make a mistake during assembly. We thank you for your understanding.

fr Le sachet de visserie universel est composé pour différents types de parois de douche. Les éventuelles pièces restantes ne proviennent donc pas d'une erreur de montage de votre part. Nous comptons sur votre compréhension.

nl Dit universele schroevenpakket wordt voor diverse types douchecabines gebruikt. Eventueel overtollige onderdelen, betekent niet dat er een fout zou zijn gemerkt bij de assemblage. Wij vragen hiervoor uw begrip.

BENÖTIGTES WERKZEUG / TOOLS NEEDED
 OUTILLAGE NÉCESSAIRE / BENODIGD WERKTUIG

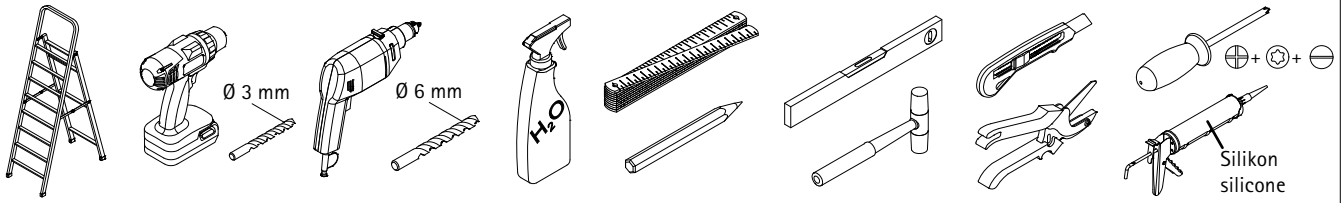

MONTAGE / ASSEMBLY / ASSEMBLAGE / ASSEMBLAGE

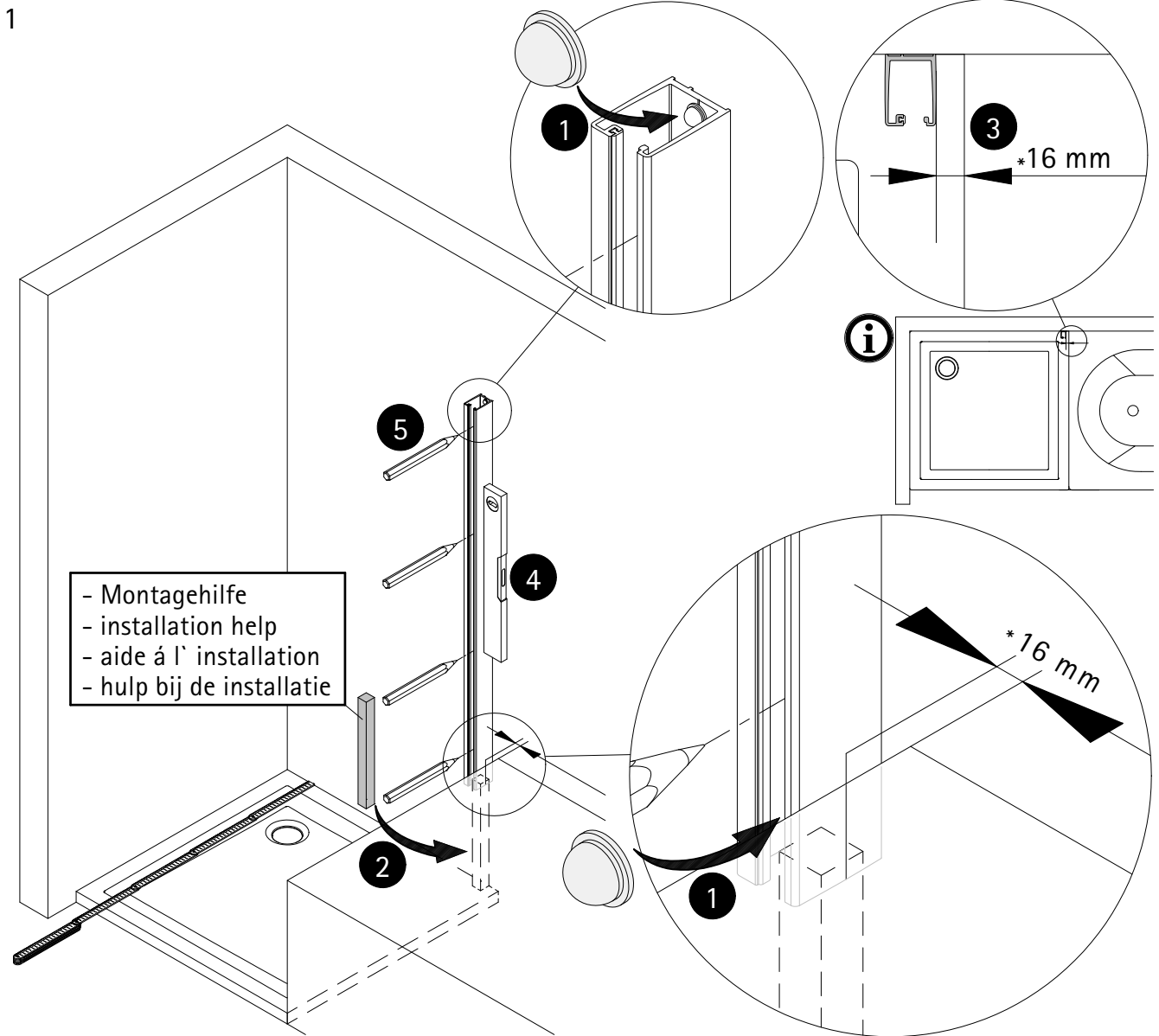

de * Wird die Duschwanne (Beispiel 900 x 900 mm) vor die Fliesen gesetzt und das gemessene Maß liegt zwischen 895 mm und maximal 905 mm erhöht sich das Einrückmaß auf 26 mm

de * If the shower tray (for example 900 x 900 mm) is installed in front of the tiles and the measured dimension is between 895 mm and a maximum of 905 mm, the inset dimension increases to 26 mm.

de * Si le receveur de douche (par exemple 900 x 900 mm) est installé devant le carrelage et que la dimension mesurée se situe entre 895 mm et un maximum de 905 mm, la cote de retrait passe à 26 mm.

de * Als de douchebak (bijvoorbeeld 900 x 900 mm) vóór de tegels wordt geplaatst en de gemeten maat tussen 895 mm en maximaal 905 mm ligt, wordt de inspringmaat verhoogd tot 26 mm.

2

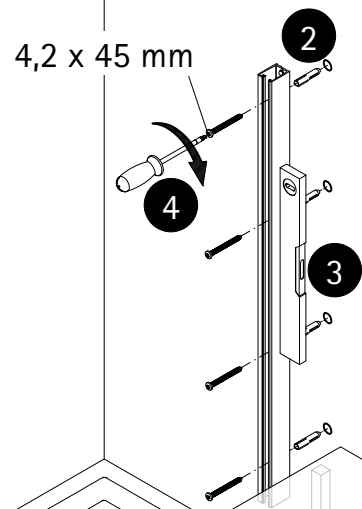
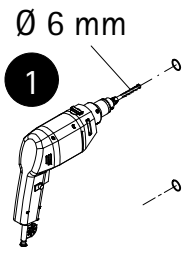
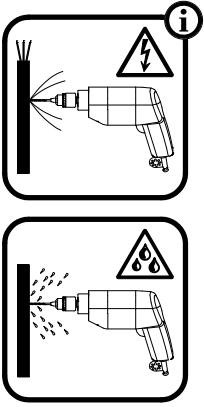

3

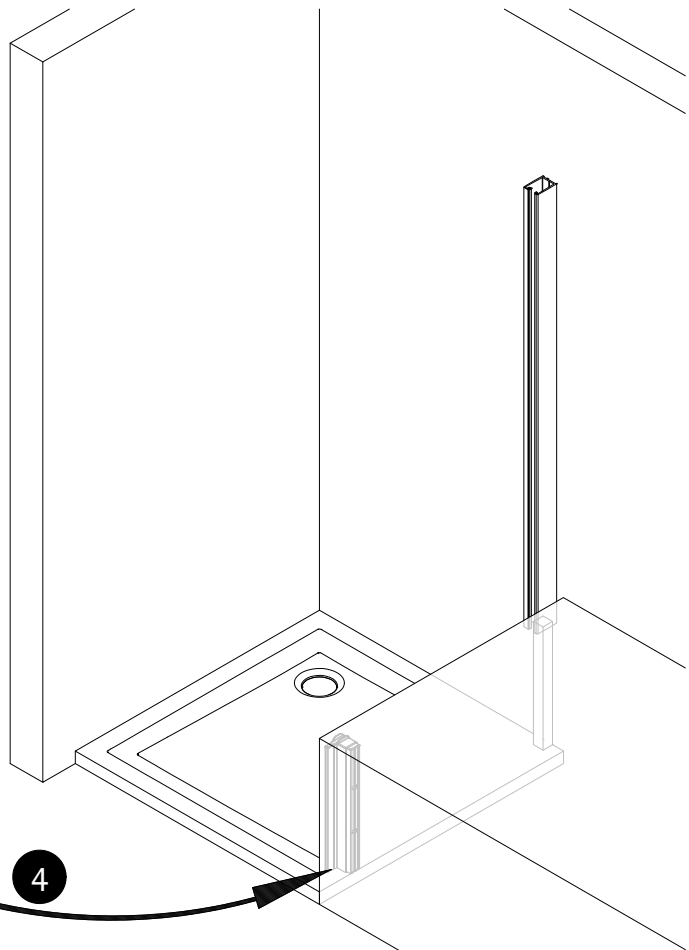
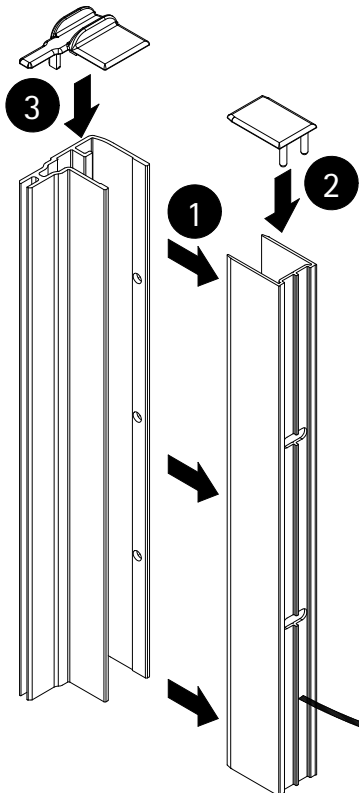

4

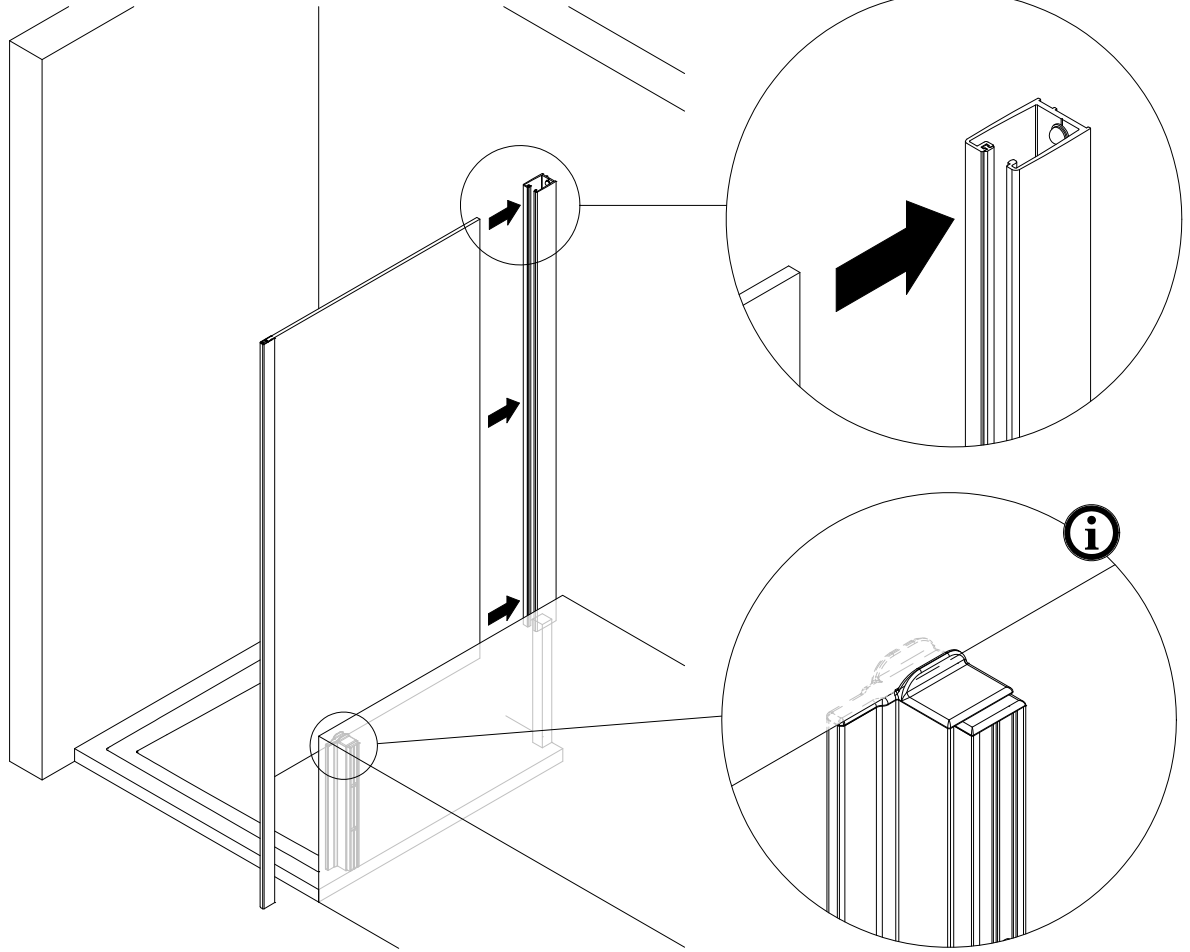

5

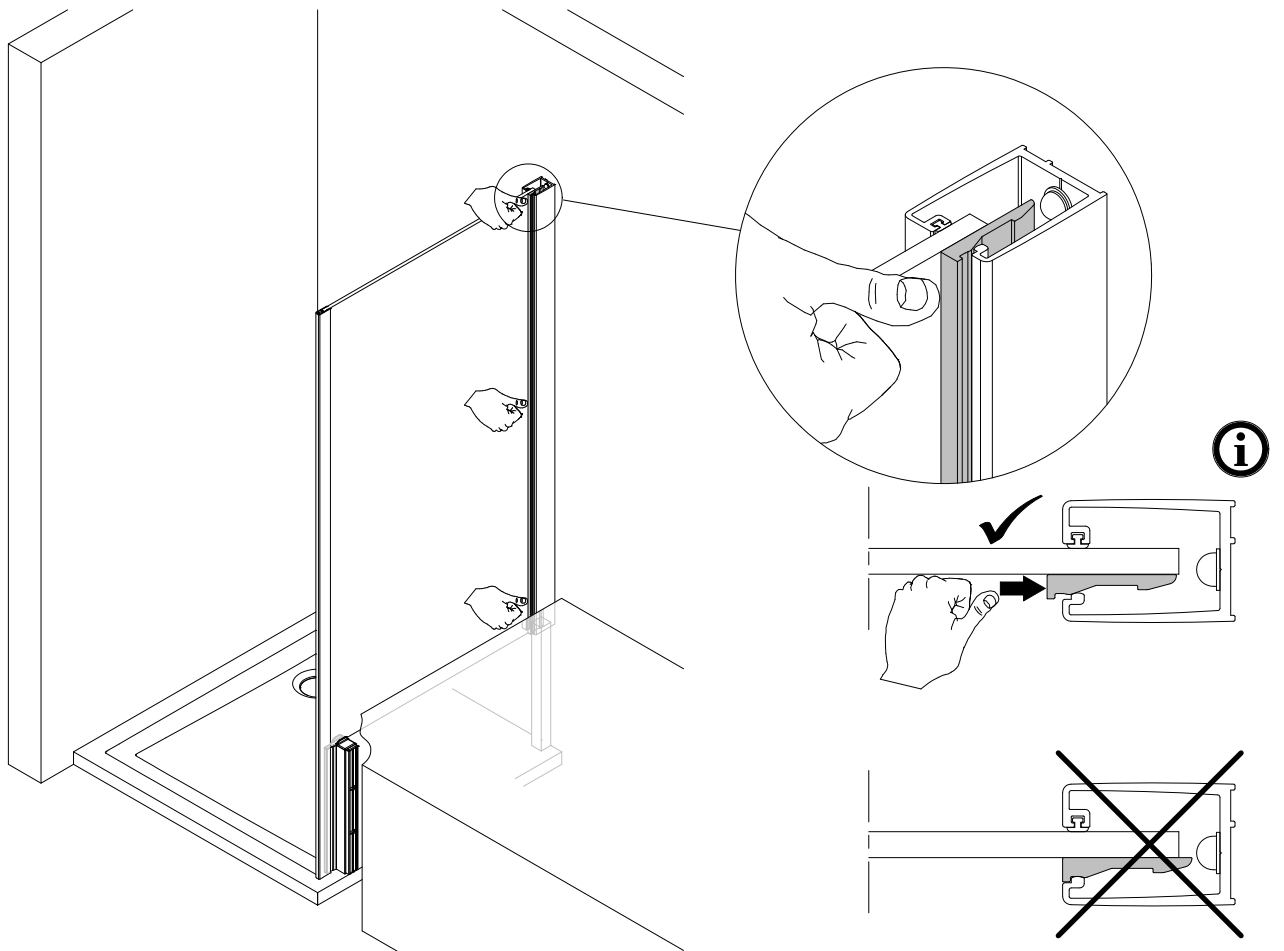

6a

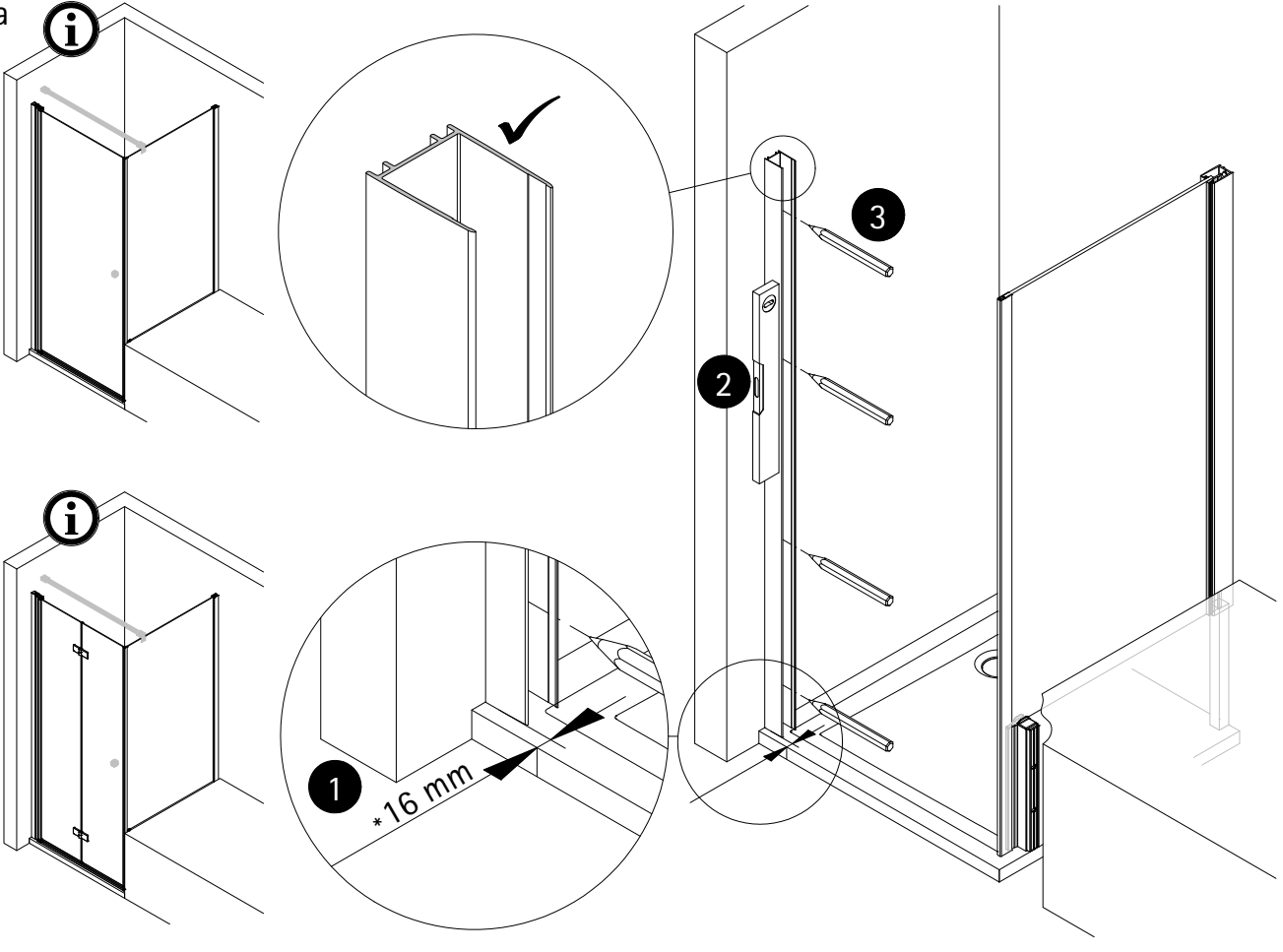

6b

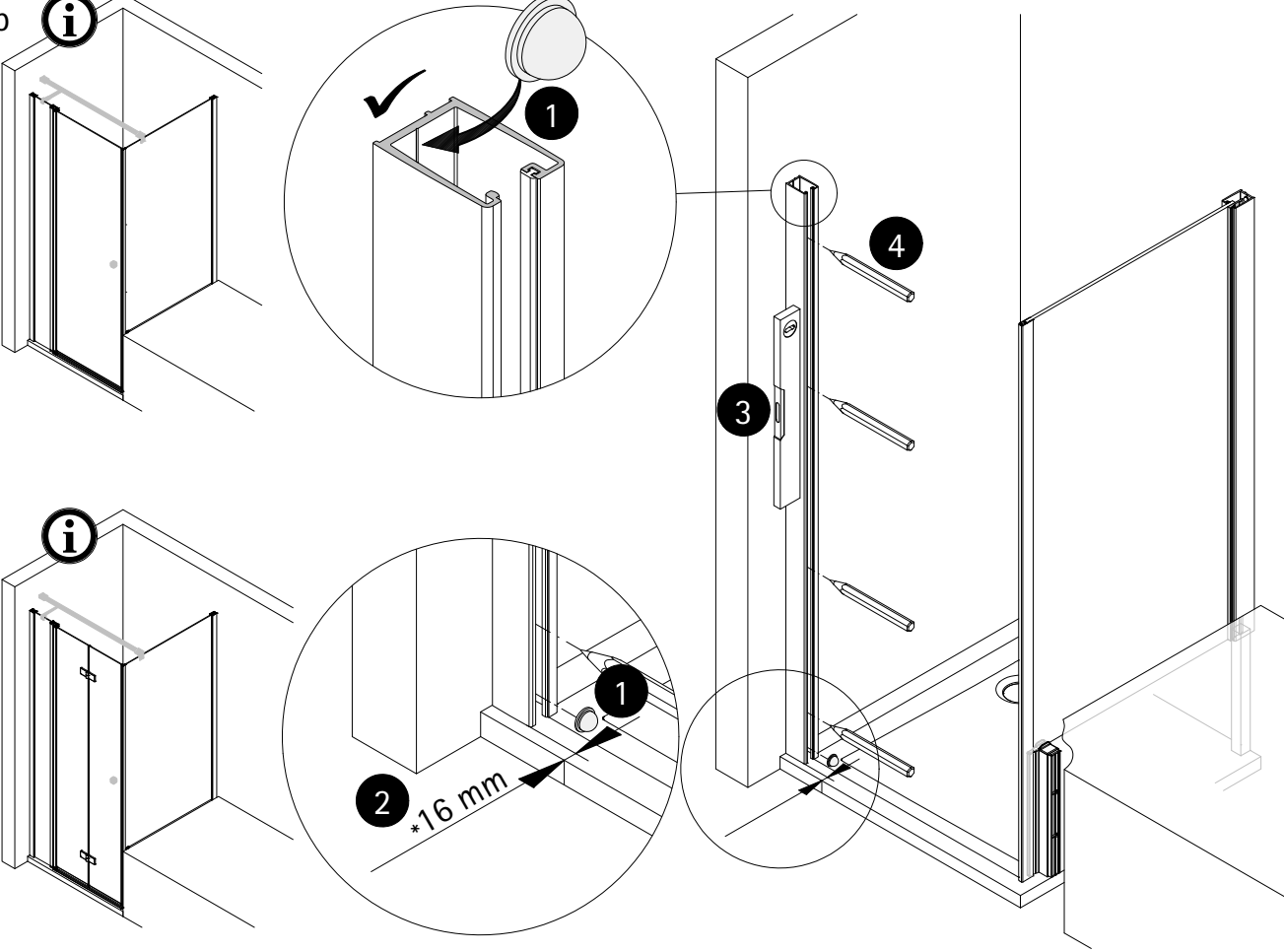

7

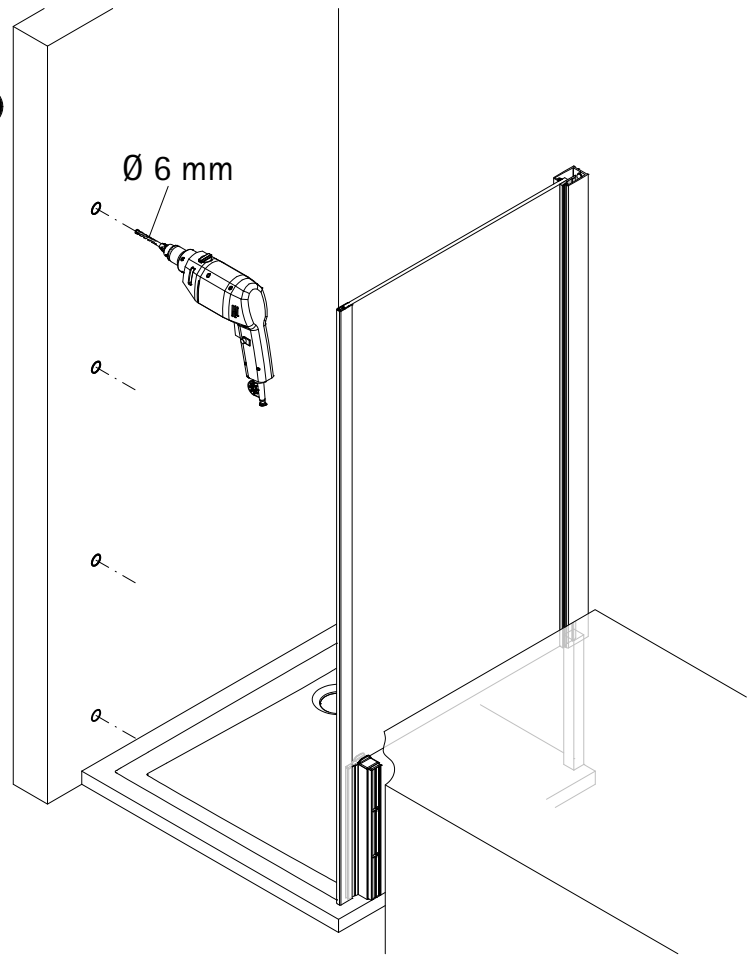
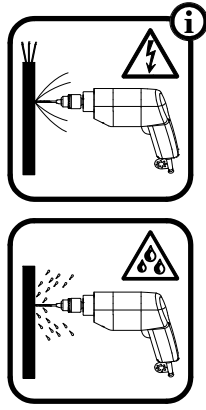

8

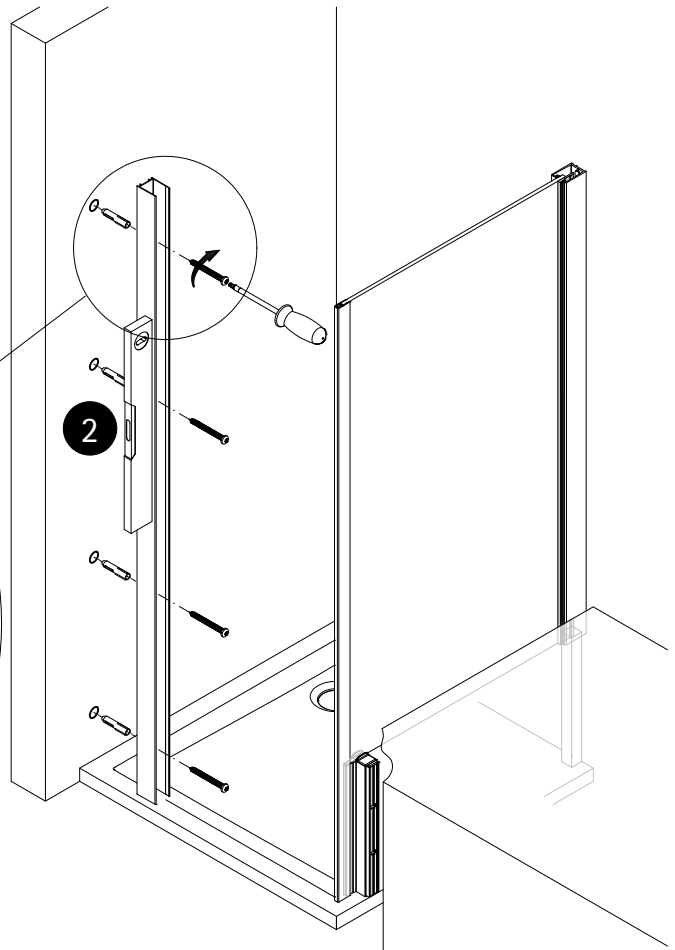
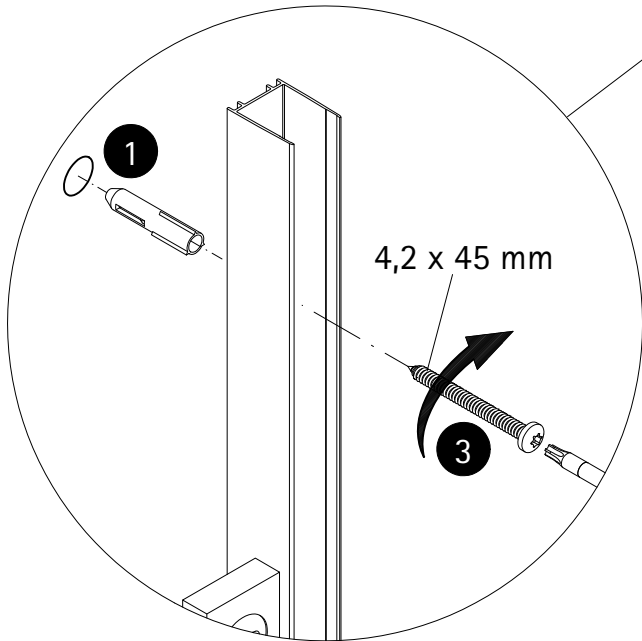
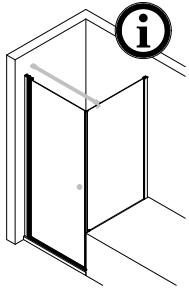

9

Aufbau der Drehtür

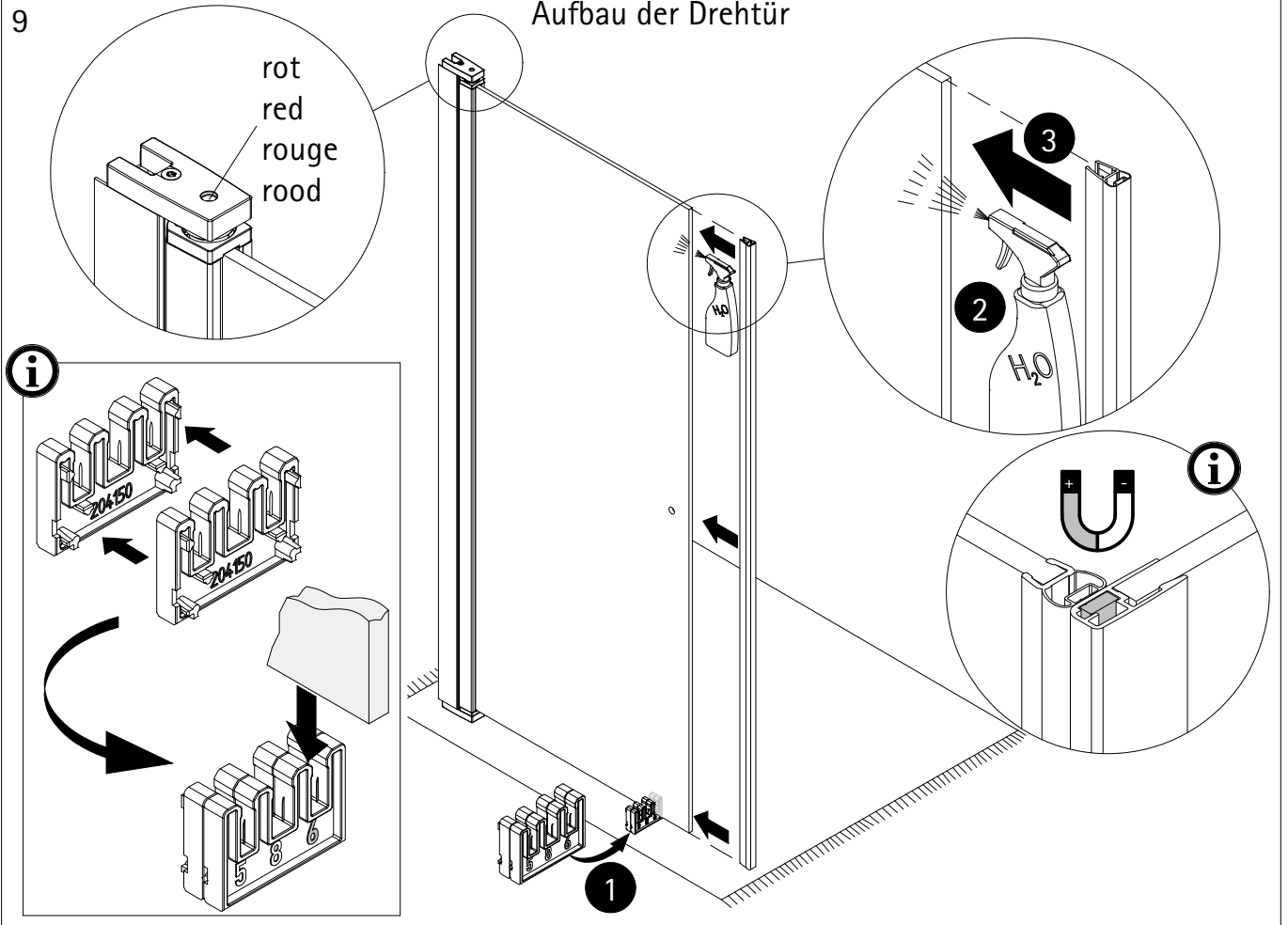

10

- Die Montage entnehmen sie dem Zusatzblatt 6460.
- Please look at the additional sheet 6460 for the installation.
- Pour le montage consultez la feuille annexe 6460.
- Voor de installatie zie aanvullende blad 6460.

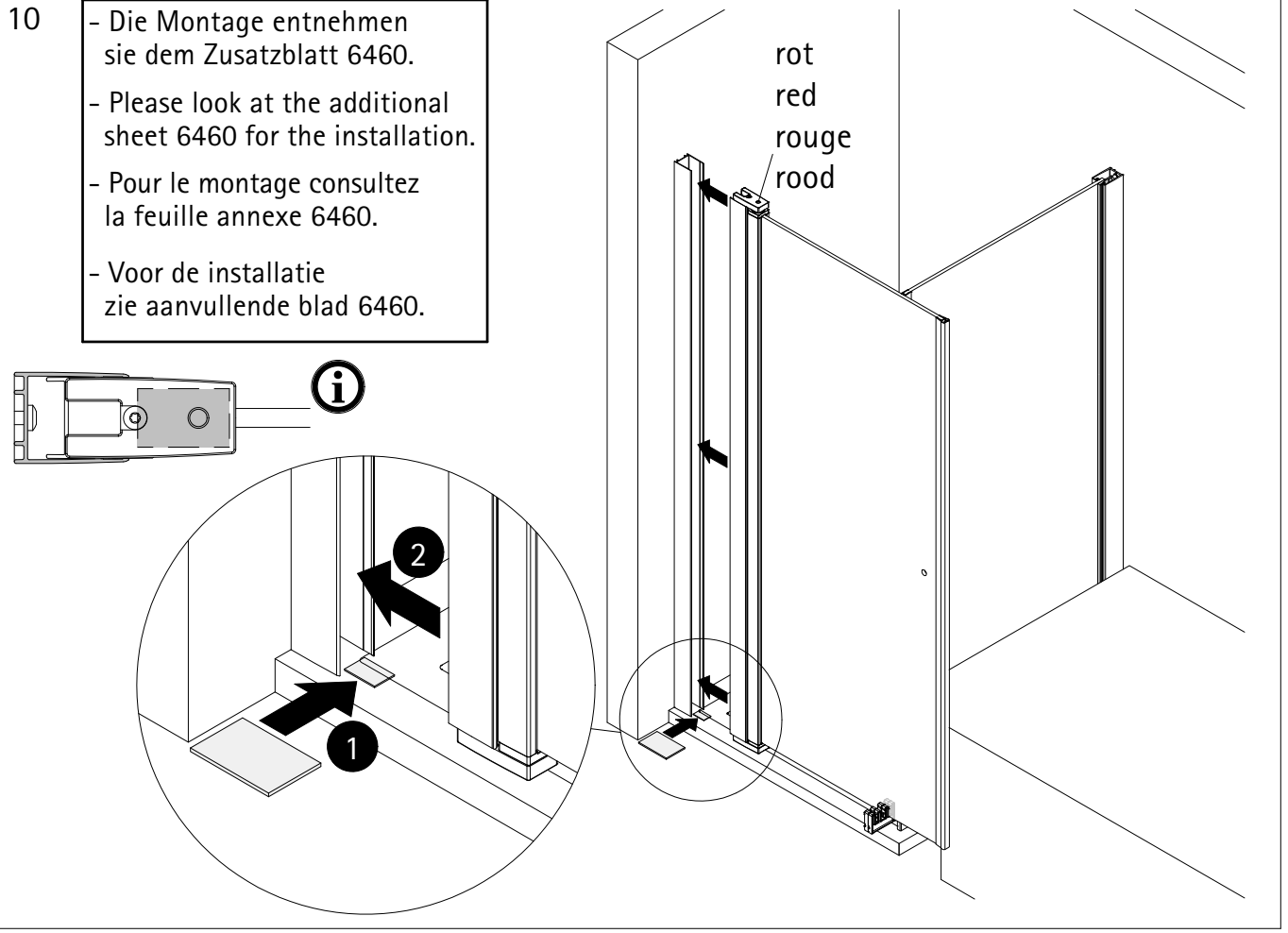

11

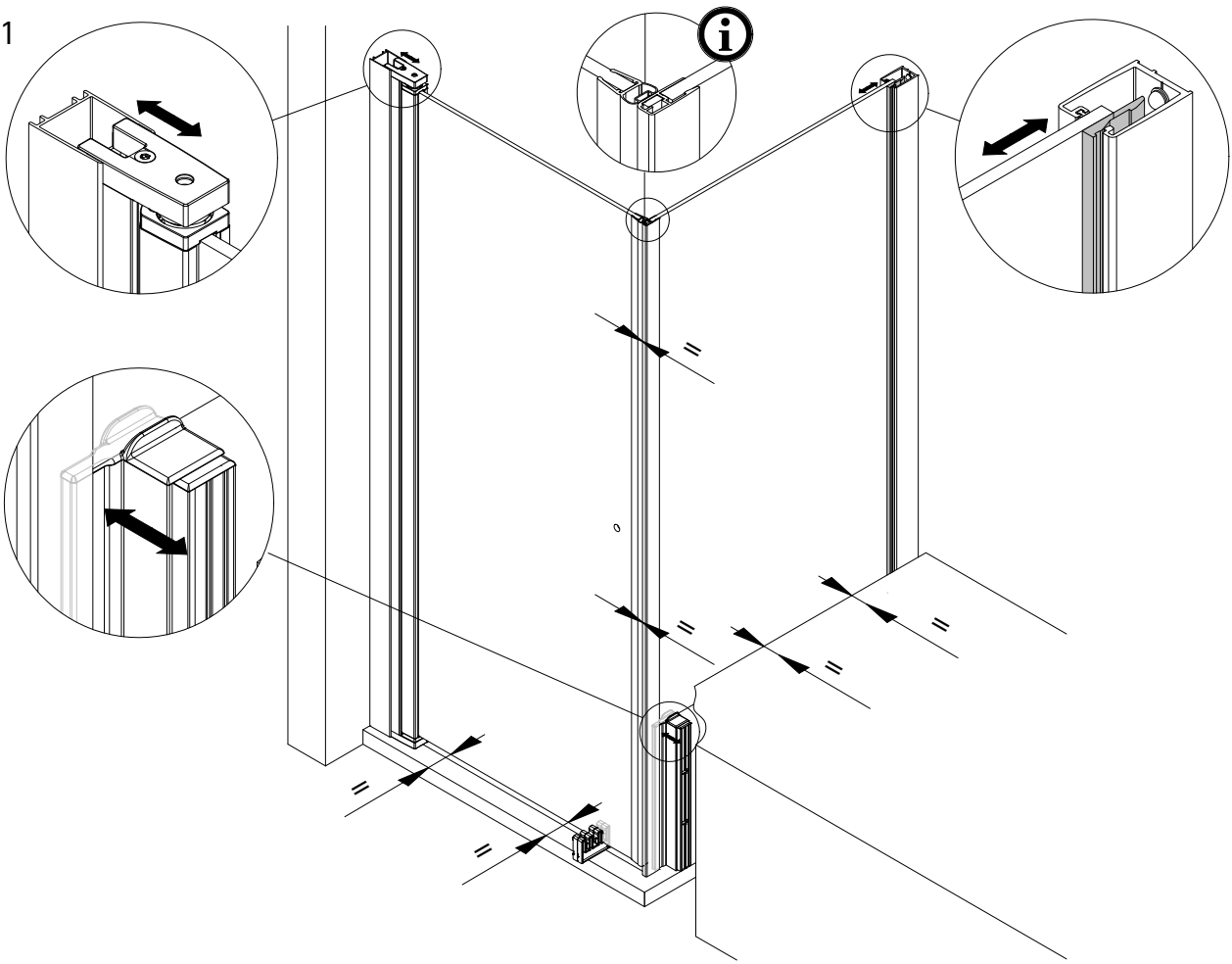

12

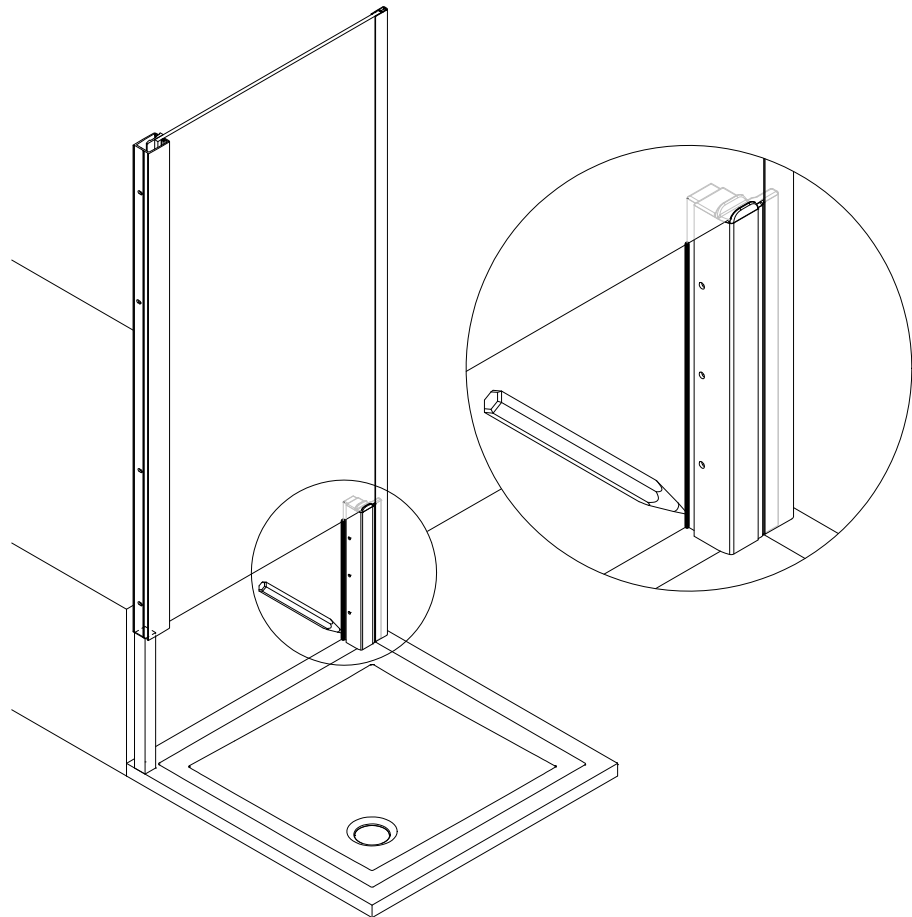

13

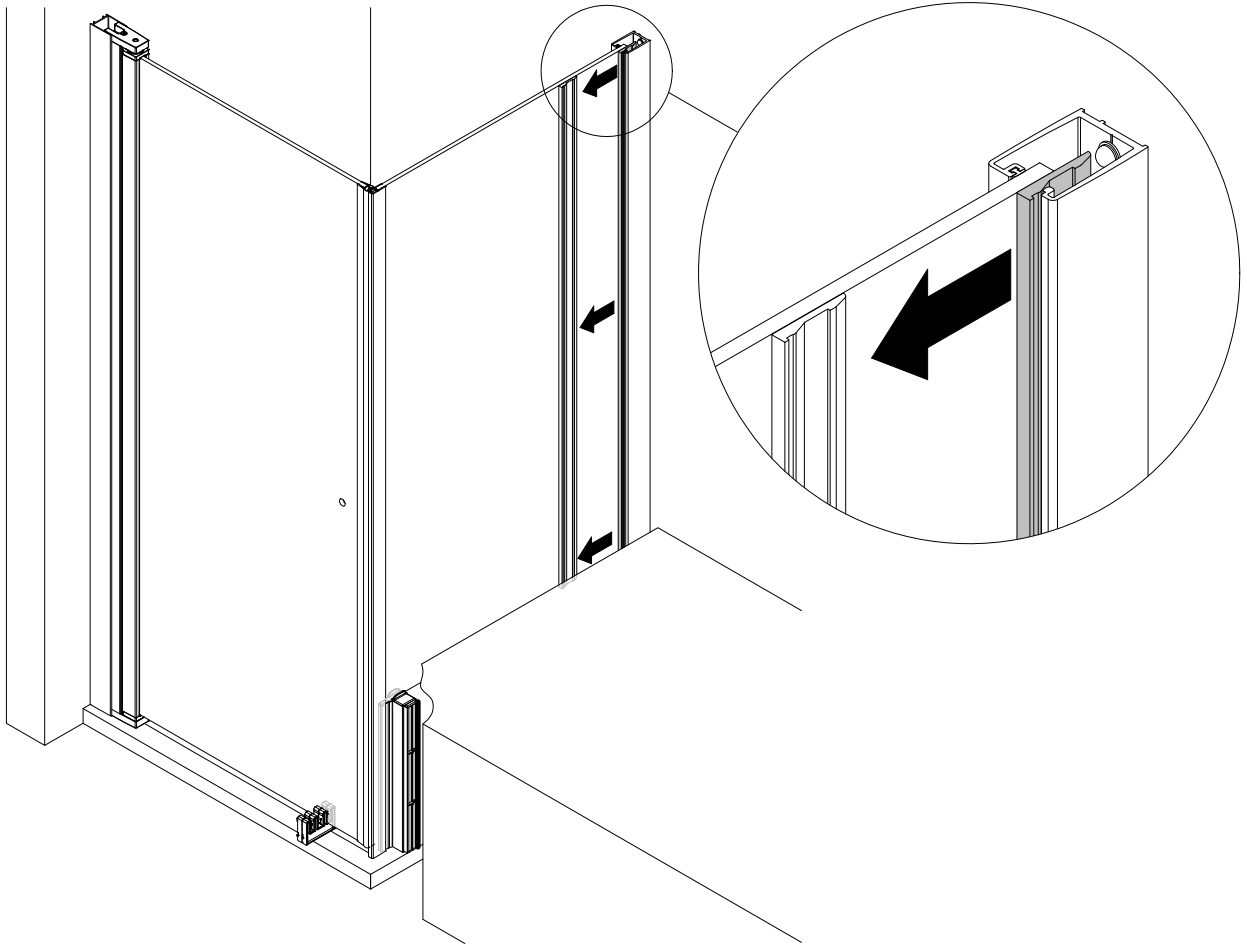

14

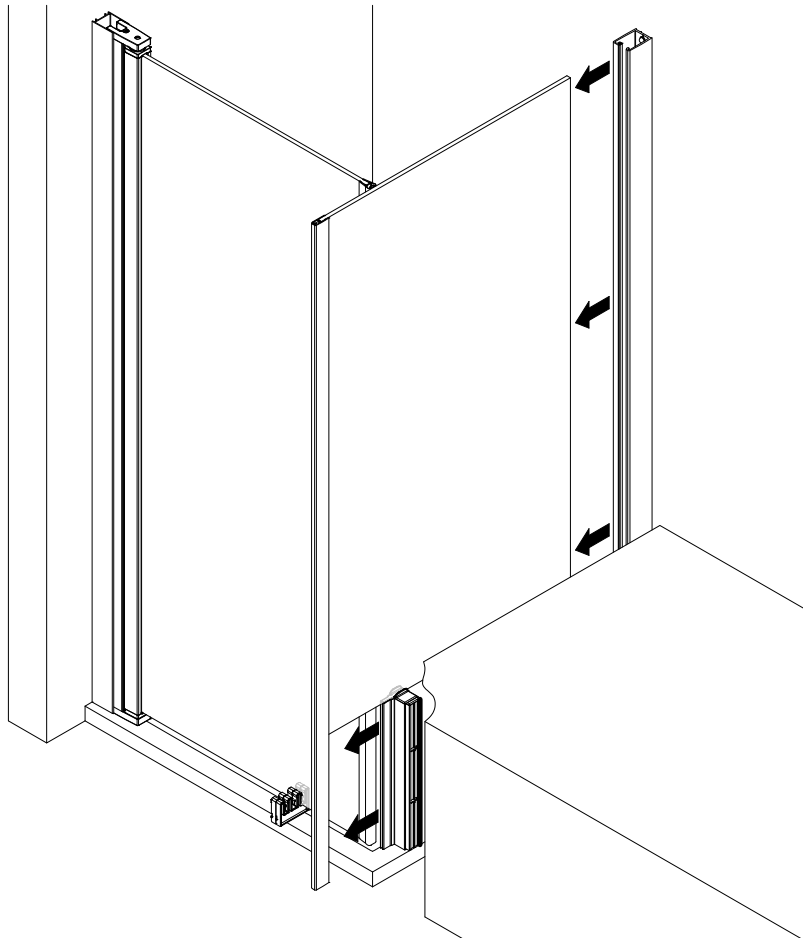

15

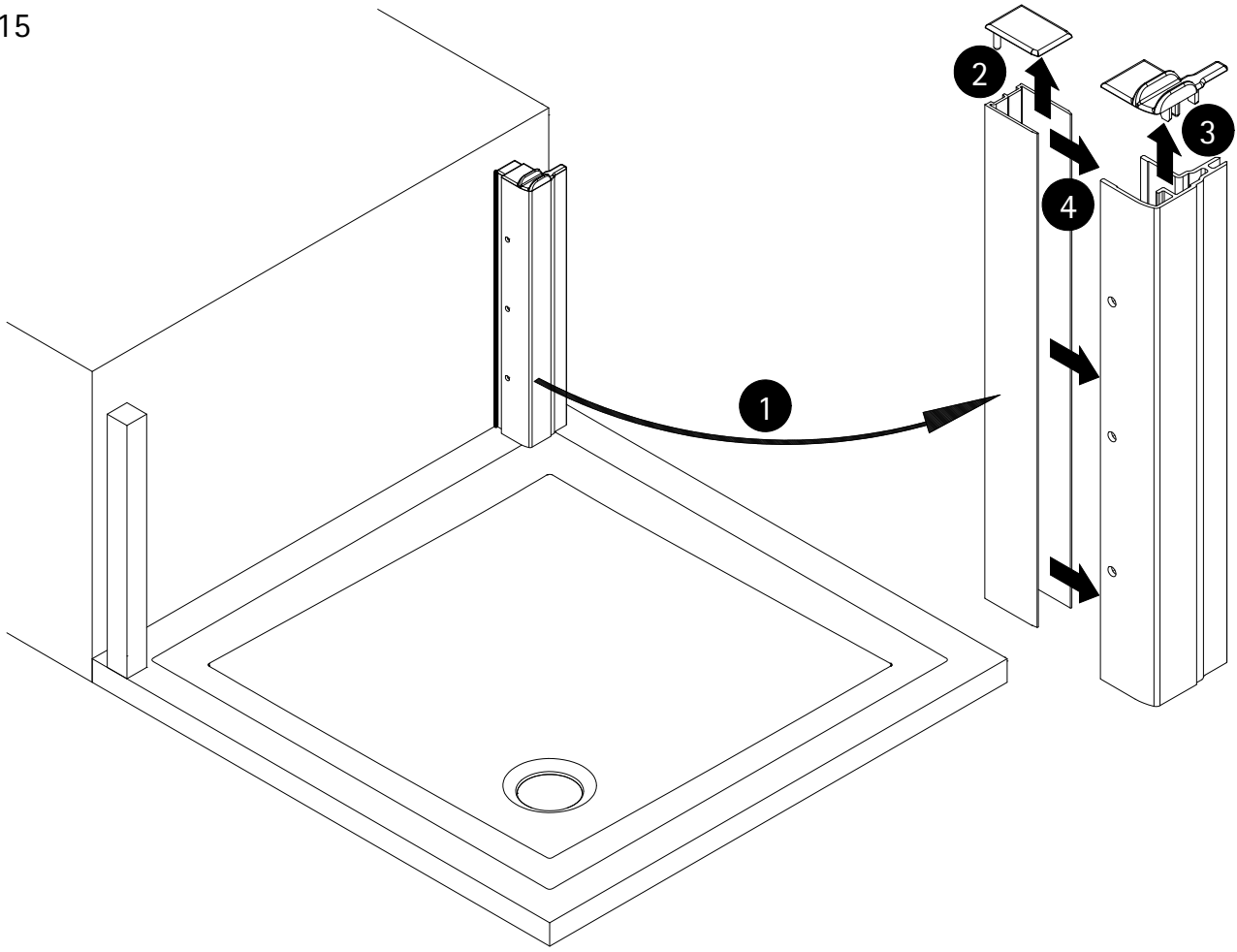

16

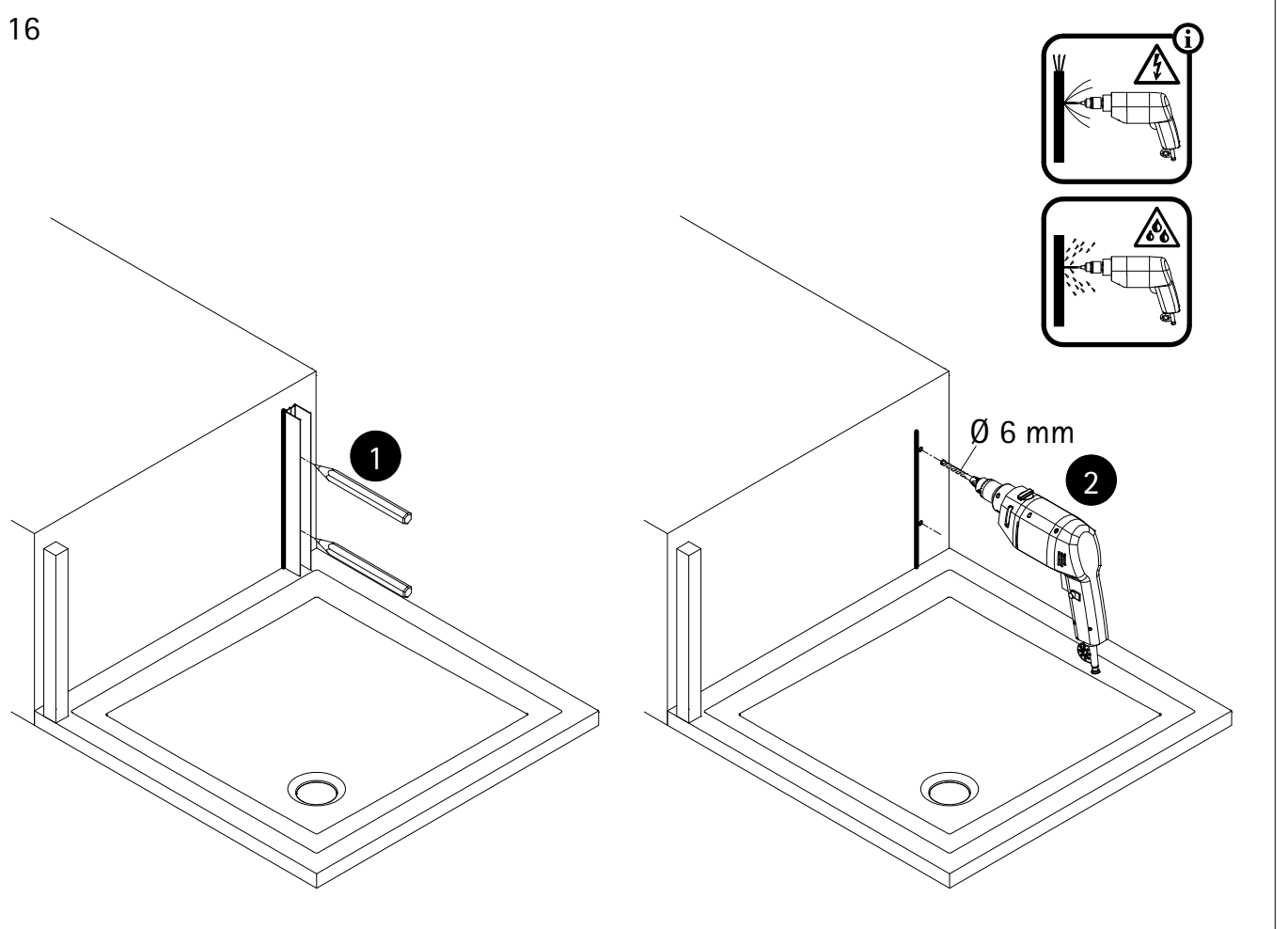

17

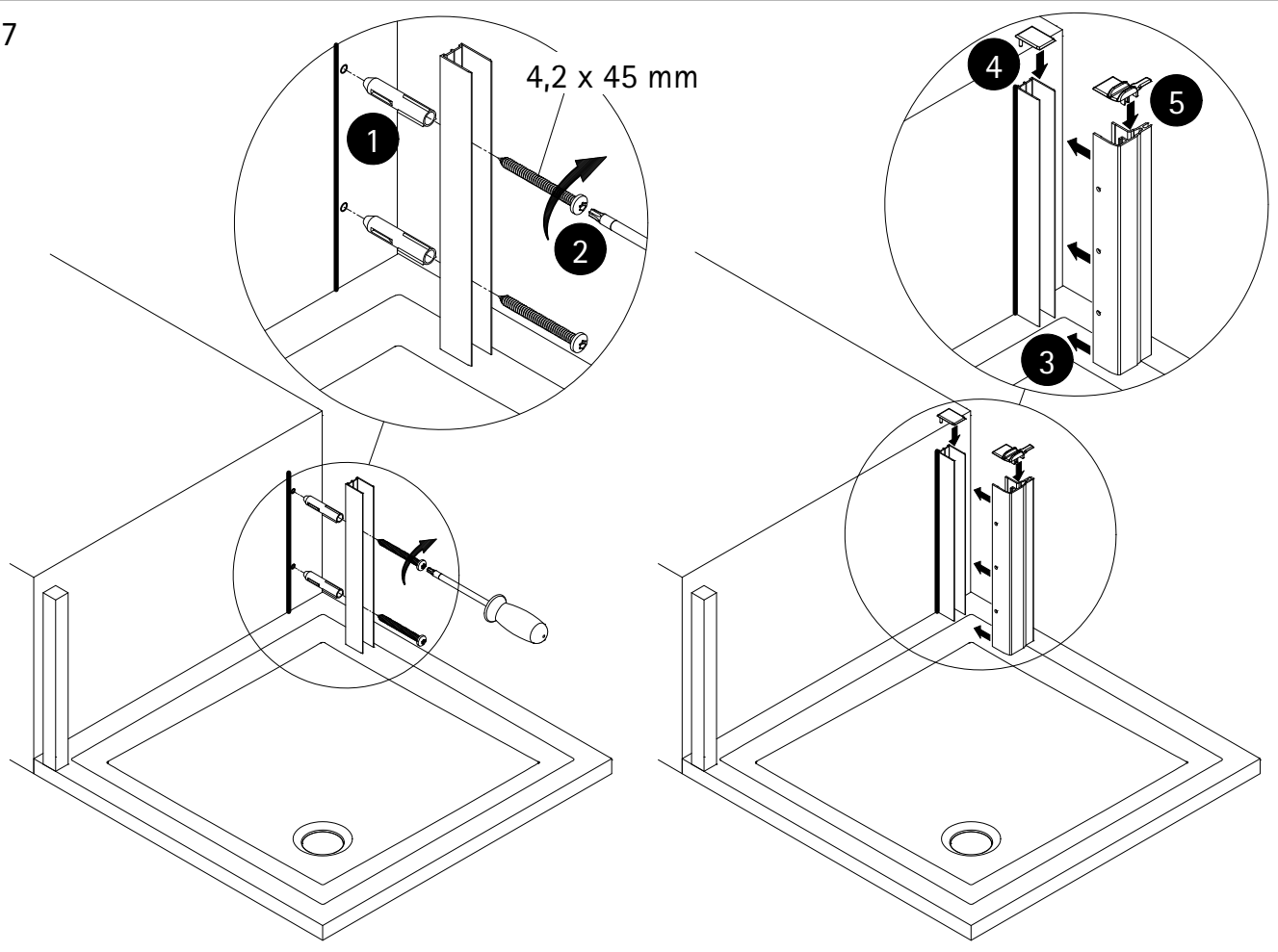

18

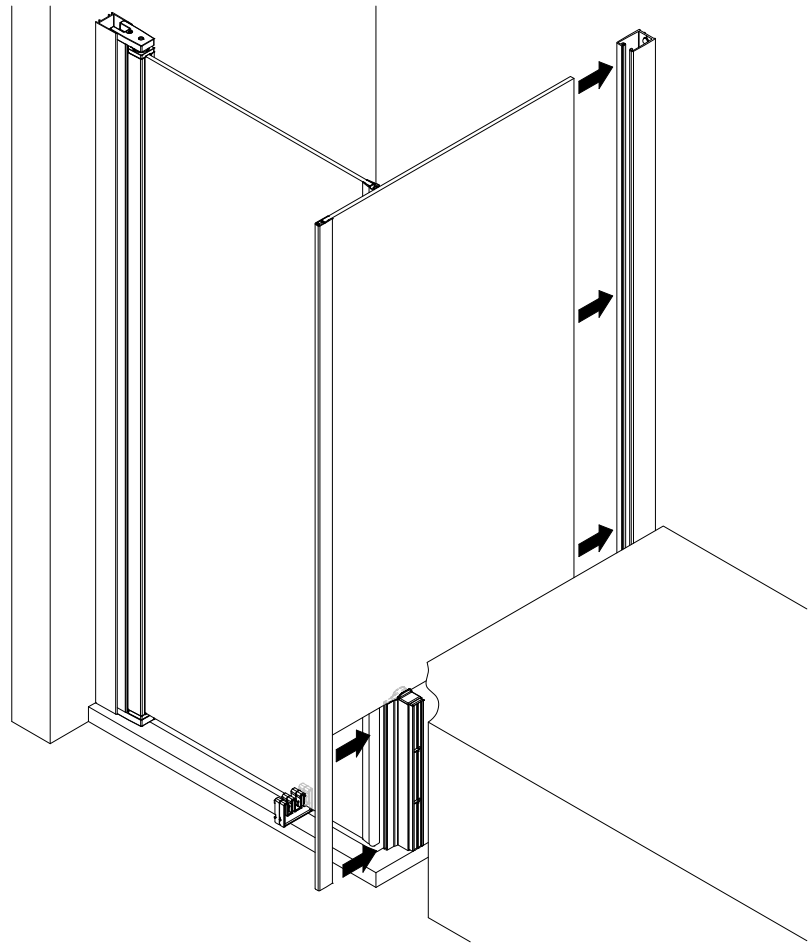

19

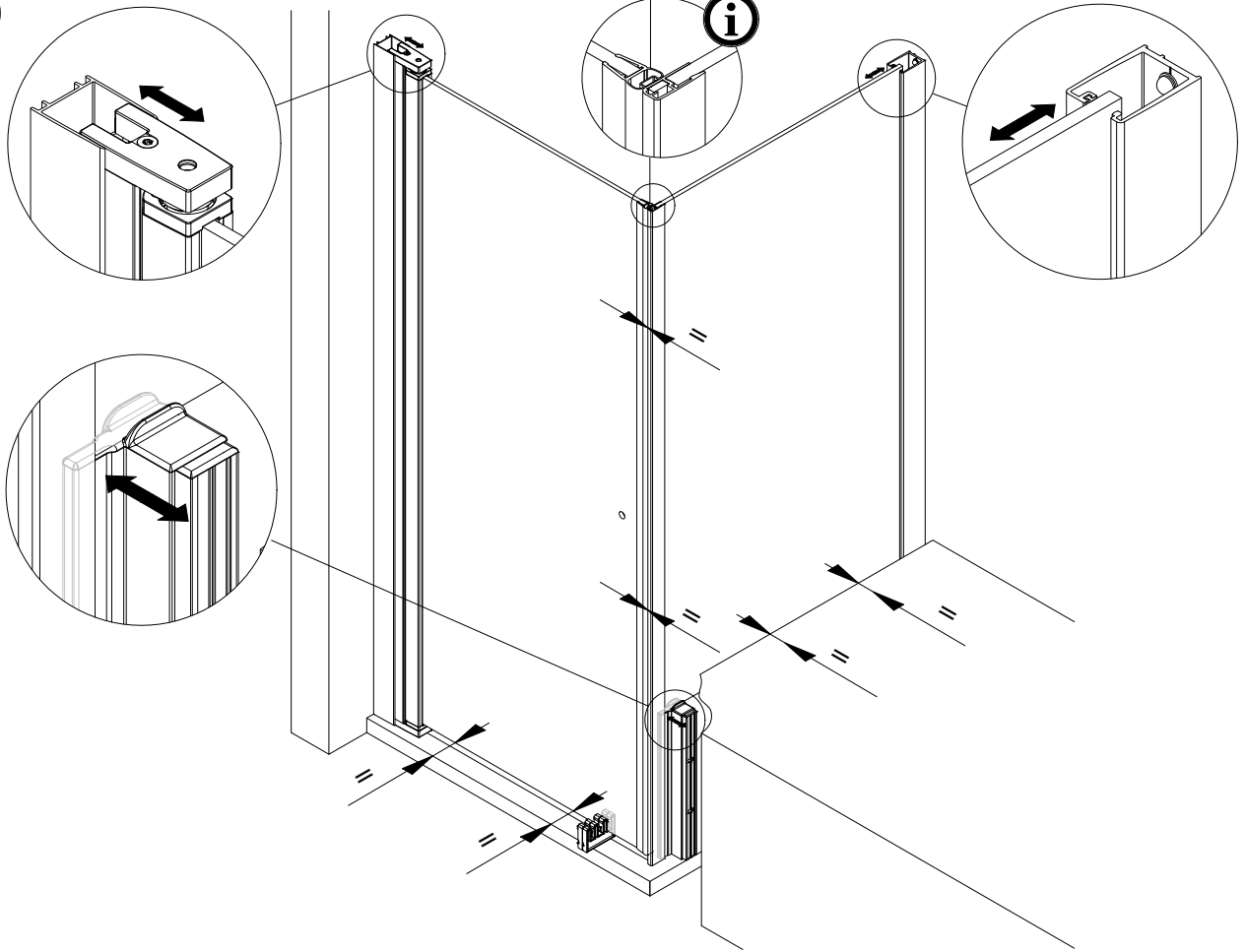

20

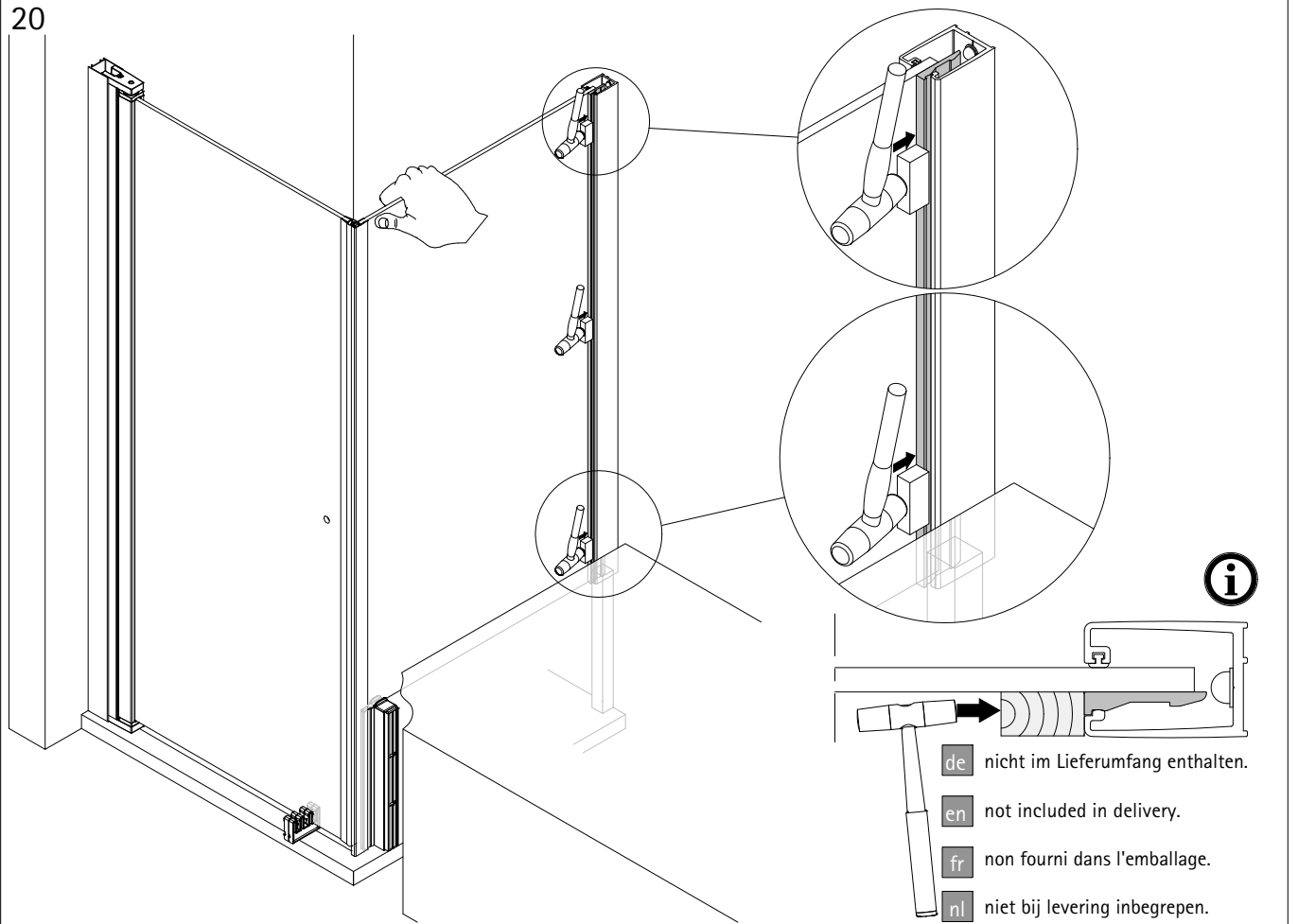

21

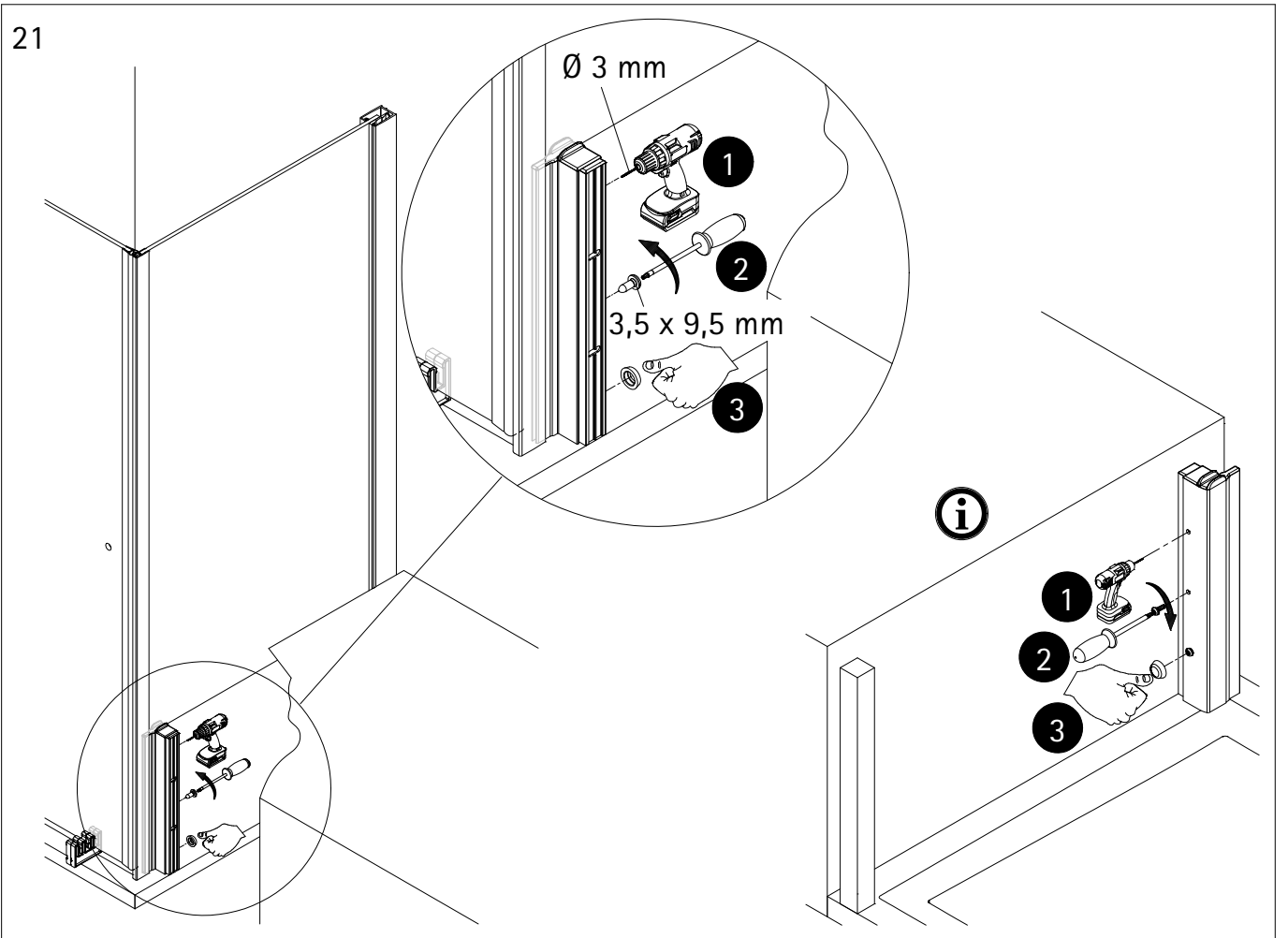

22

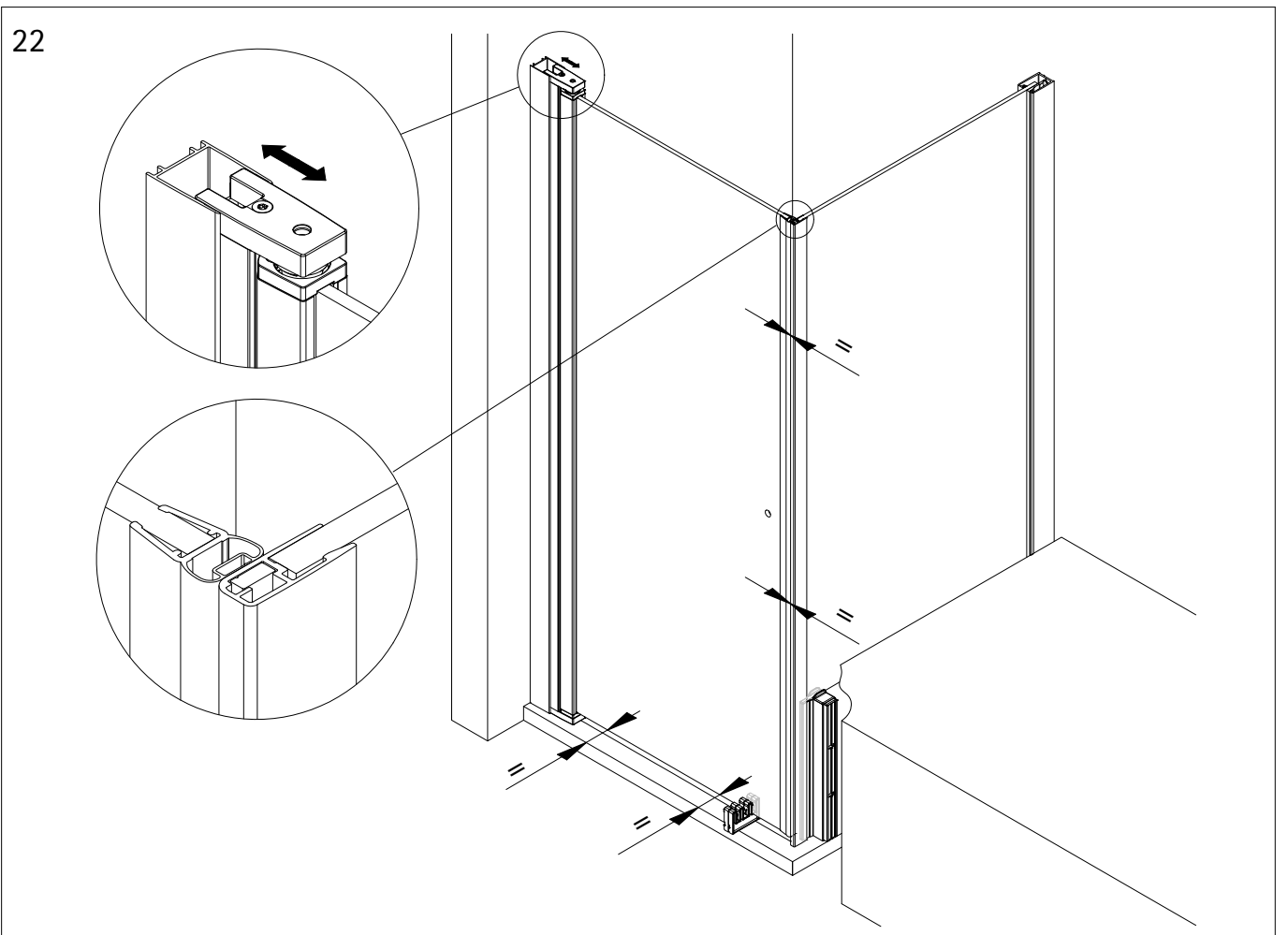

23

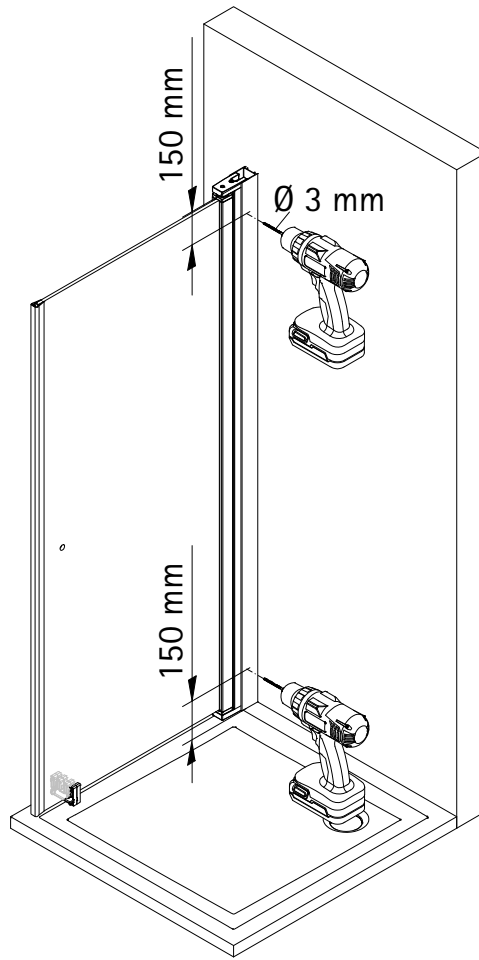
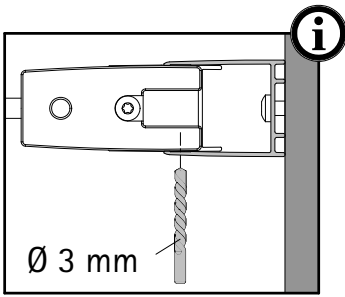

24

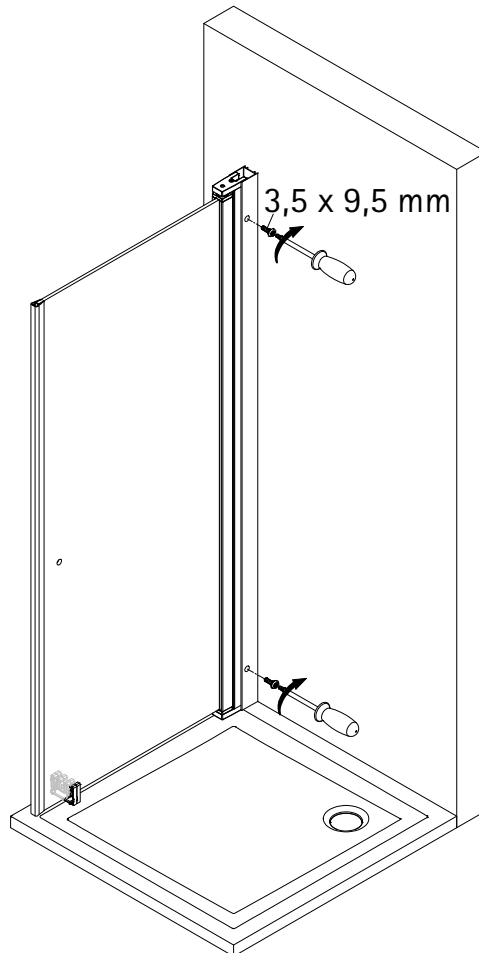
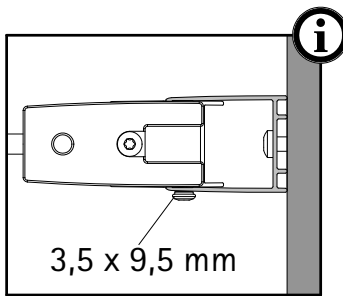

25

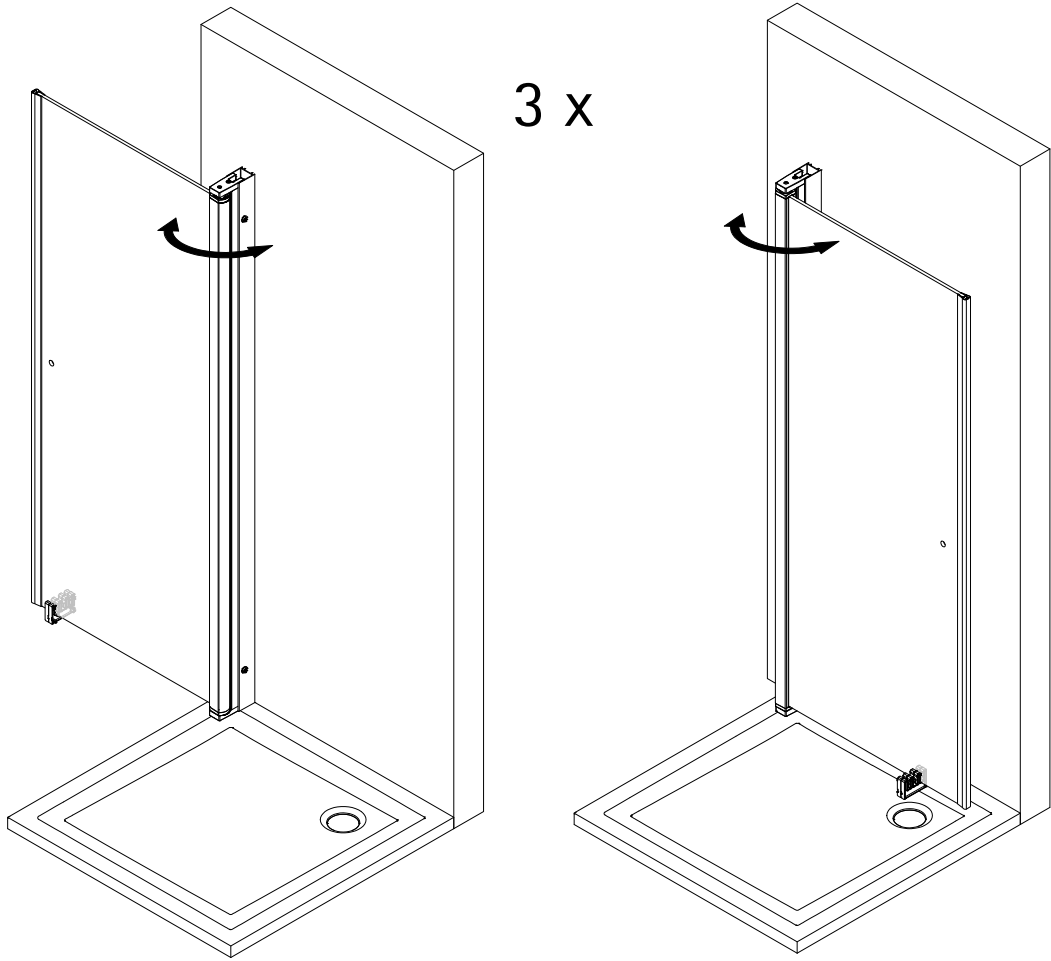

26

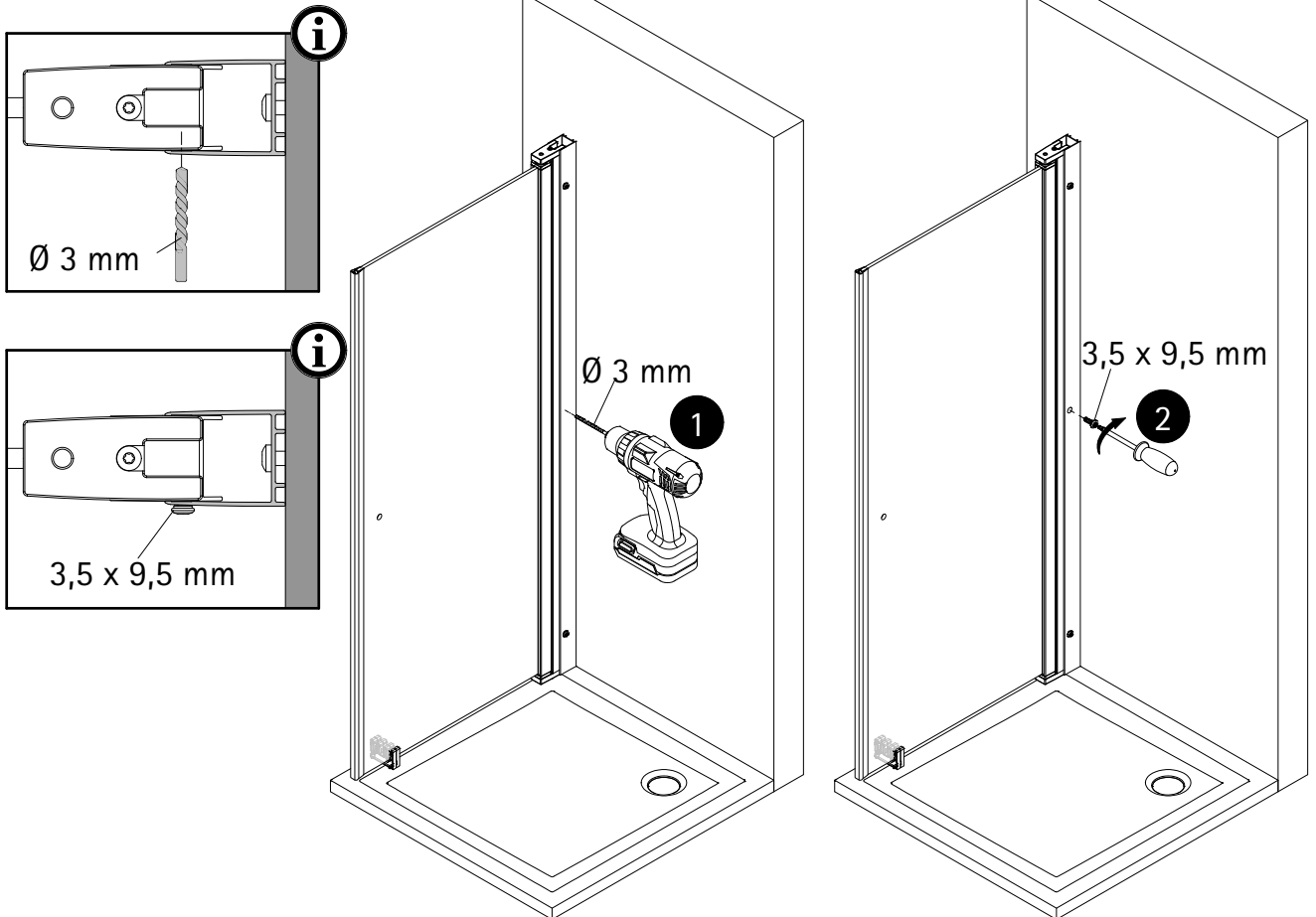

27

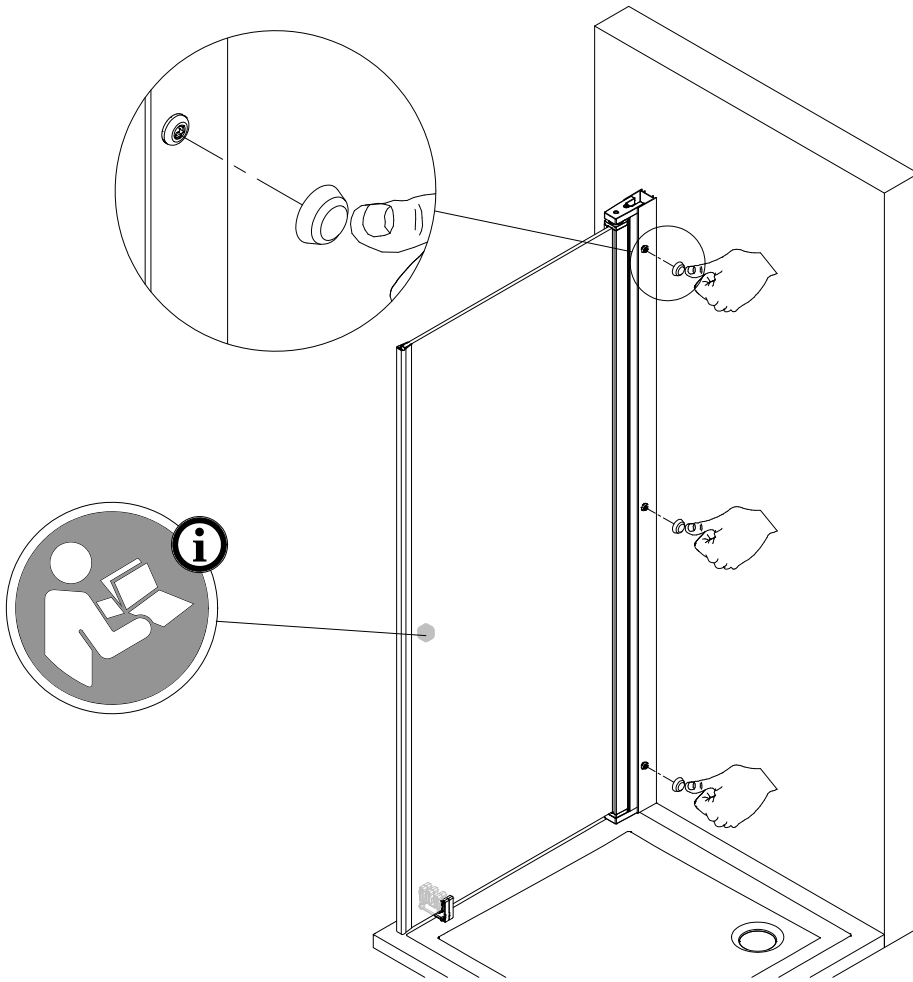

28

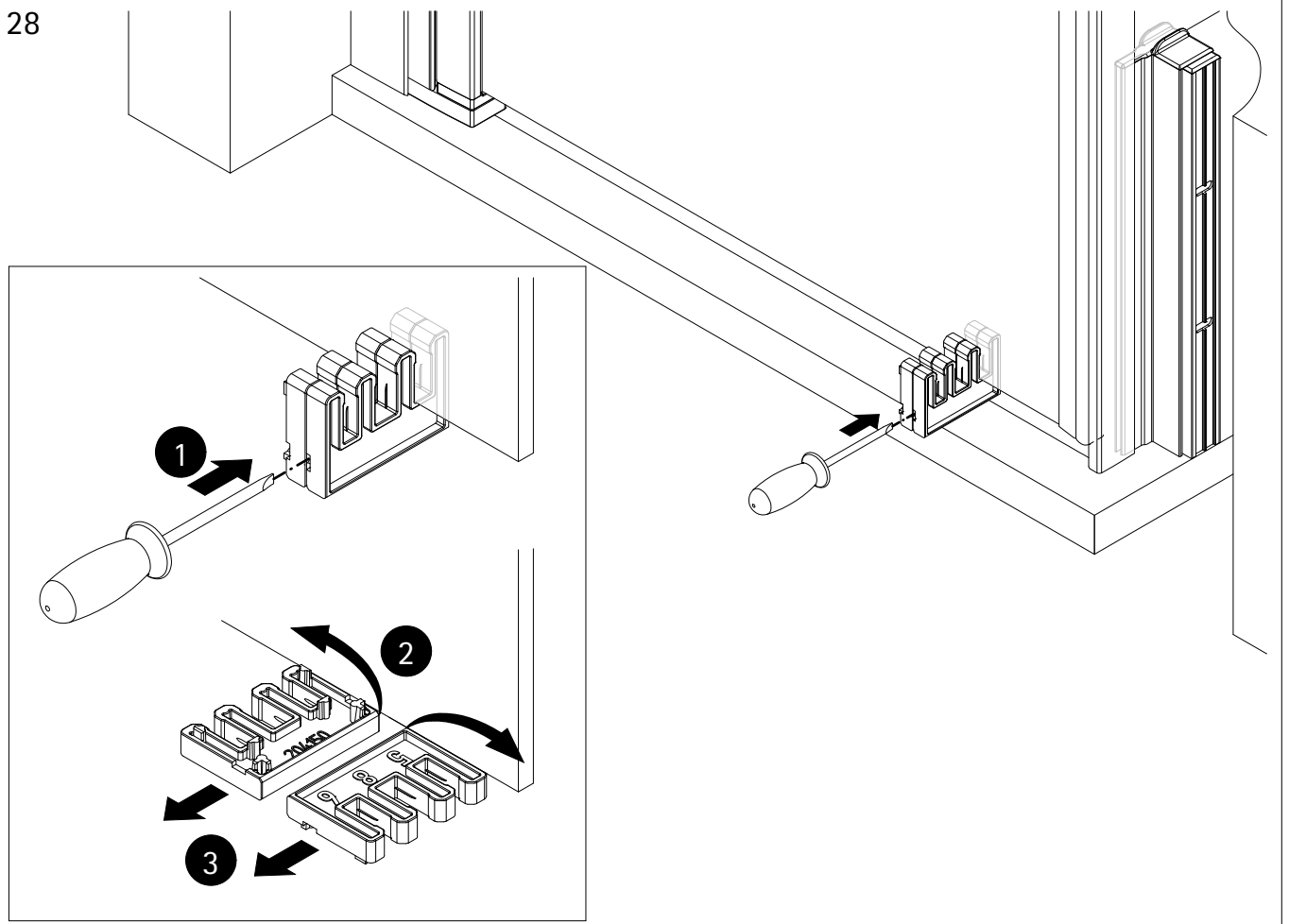

29

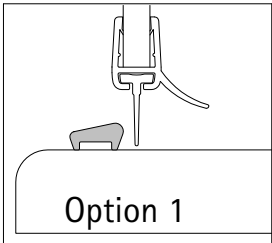

Option 1

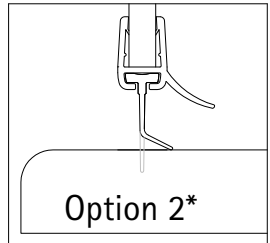

Option 2*

de * Option 2 kann zu Undichtigkeit führen. Siehe Zusatzblatt 6988.

en * Option 2 can lead to leakage. See additional sheet 6988.

fr * L'option 2 peut entraîner des problèmes 'étanchéité. Voir feuille additionnelle 6988.

nl * Optie 2 kan leiden tot lekkage. Zie Aanvullende blad 6988.

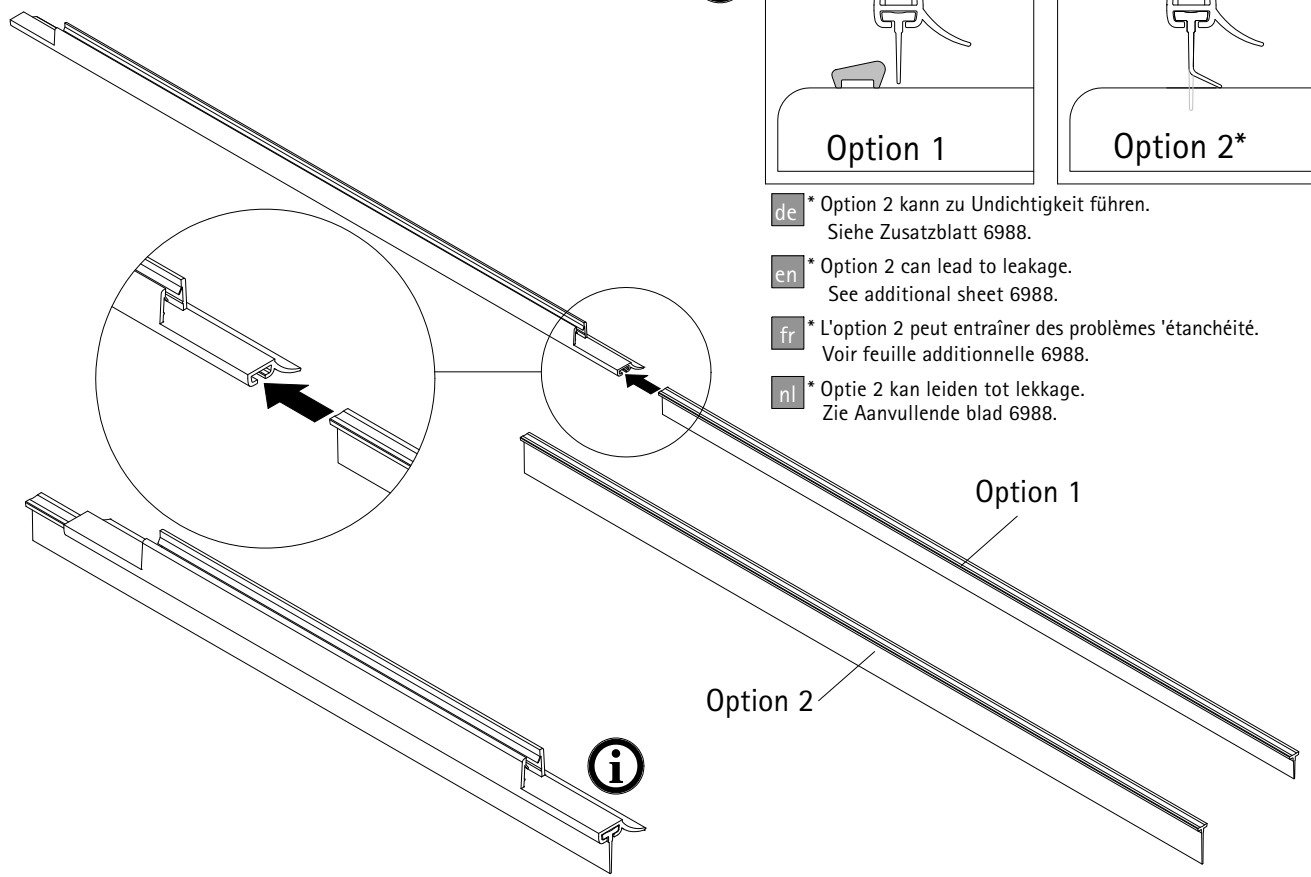

30

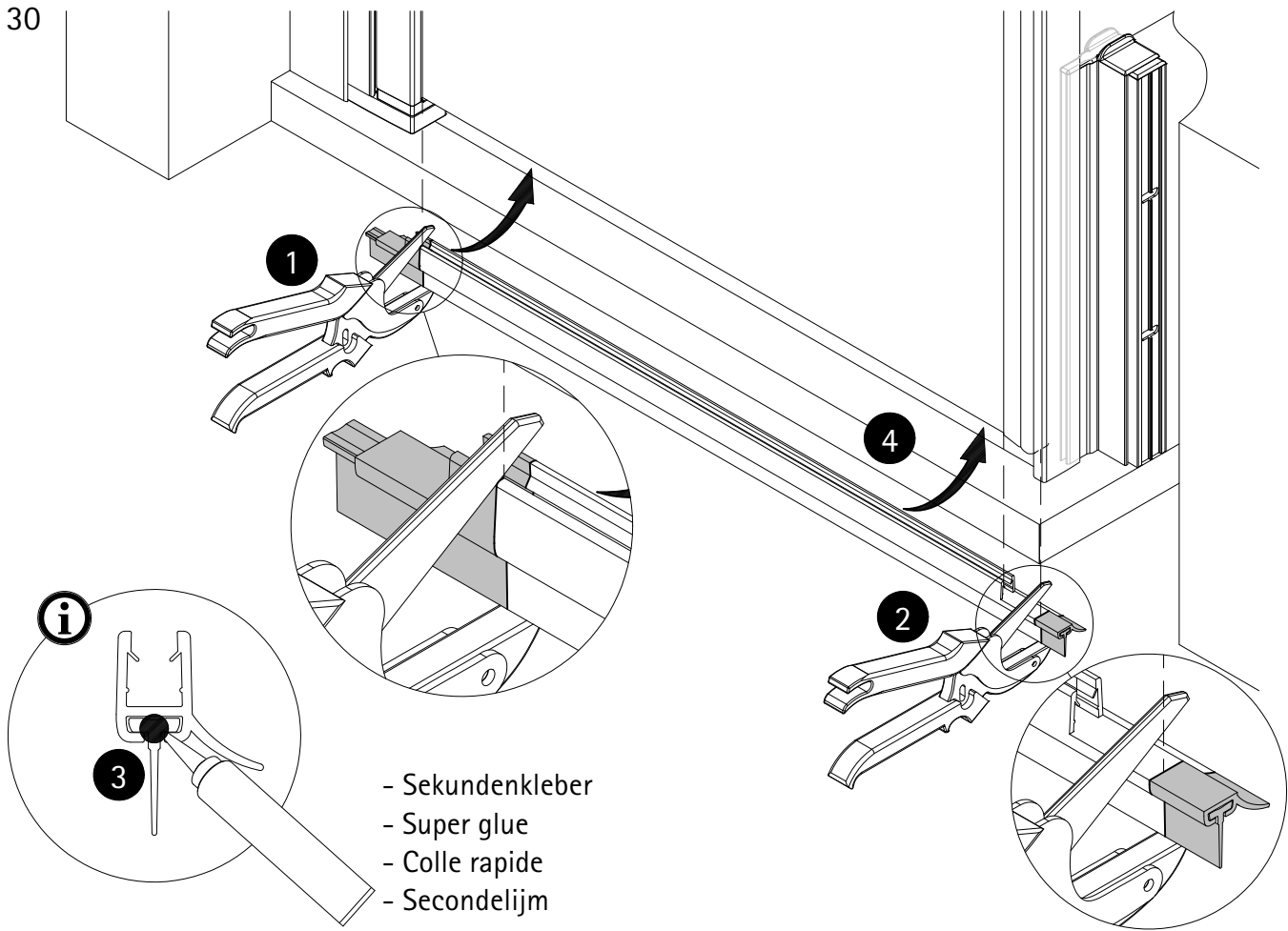

- Sekundenkleber
- Super glue
- Colle rapide
- Secondelijm

31

Option 1

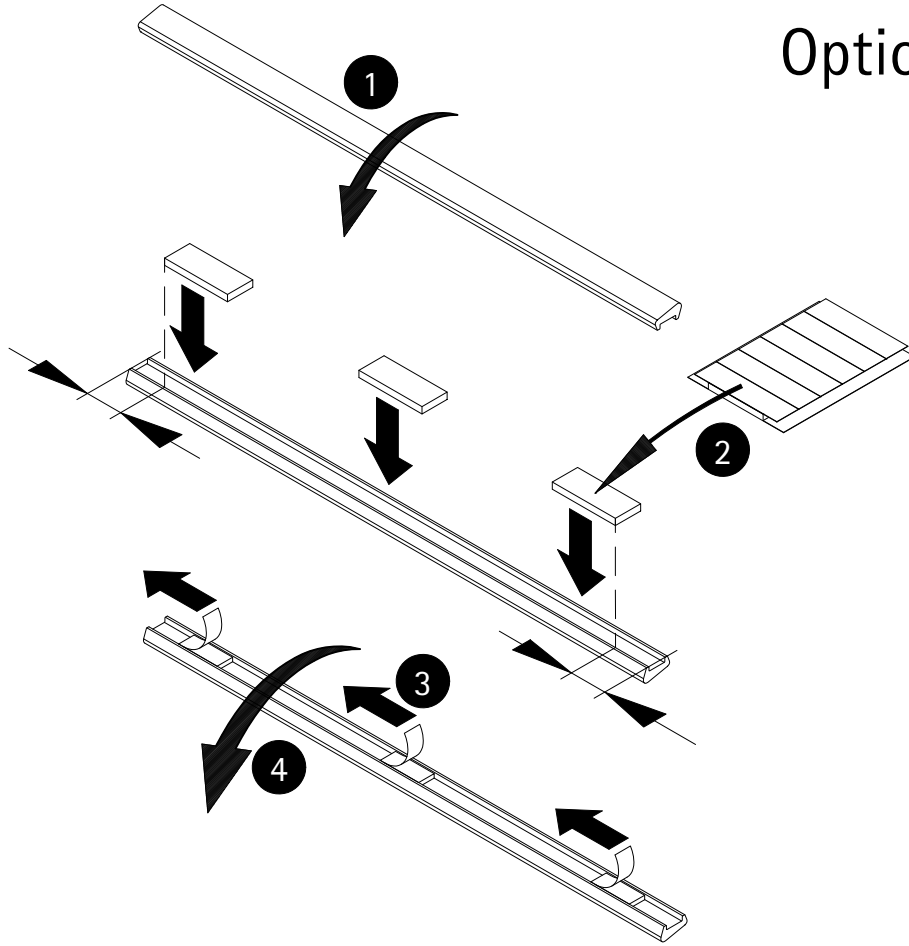

32

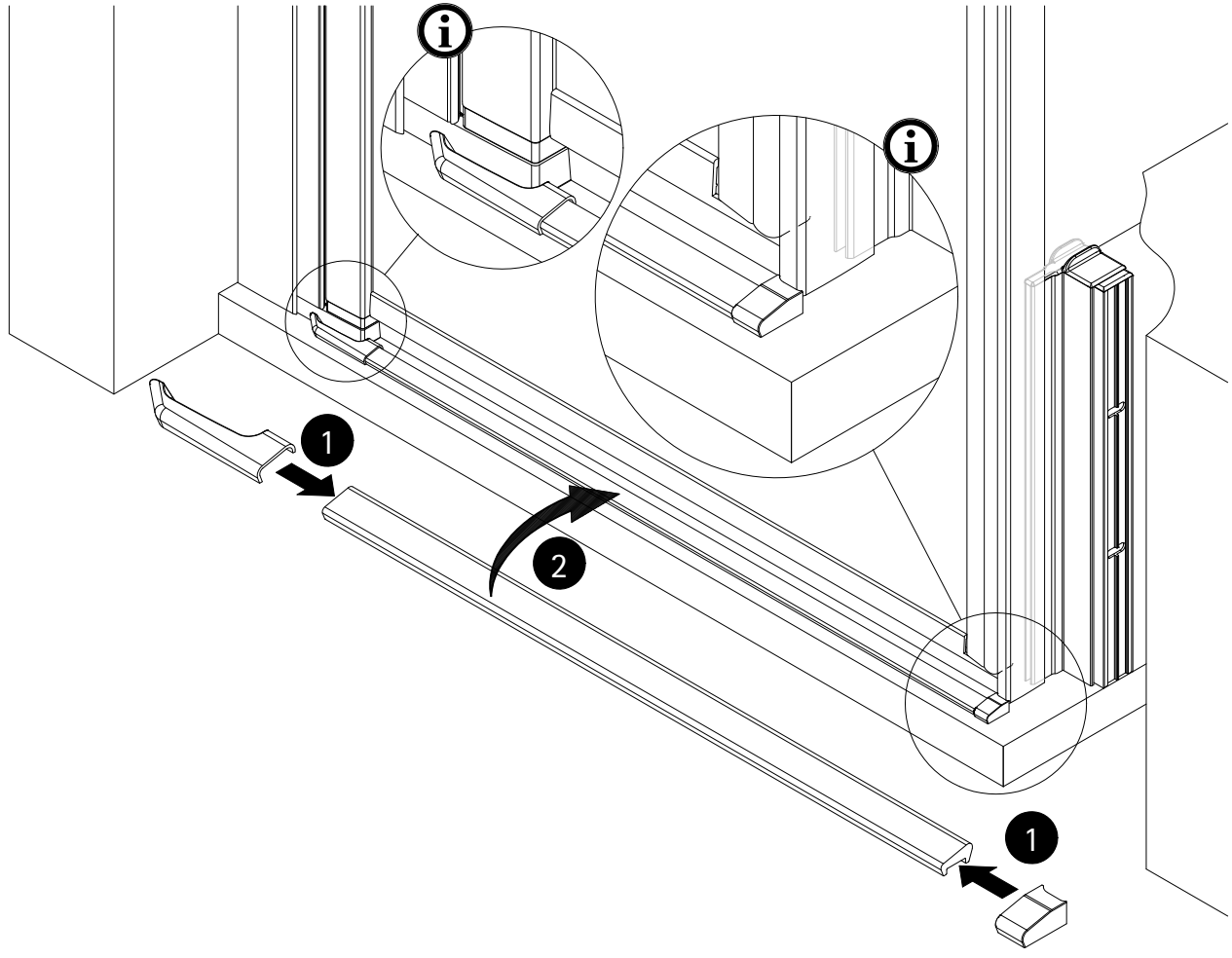

33

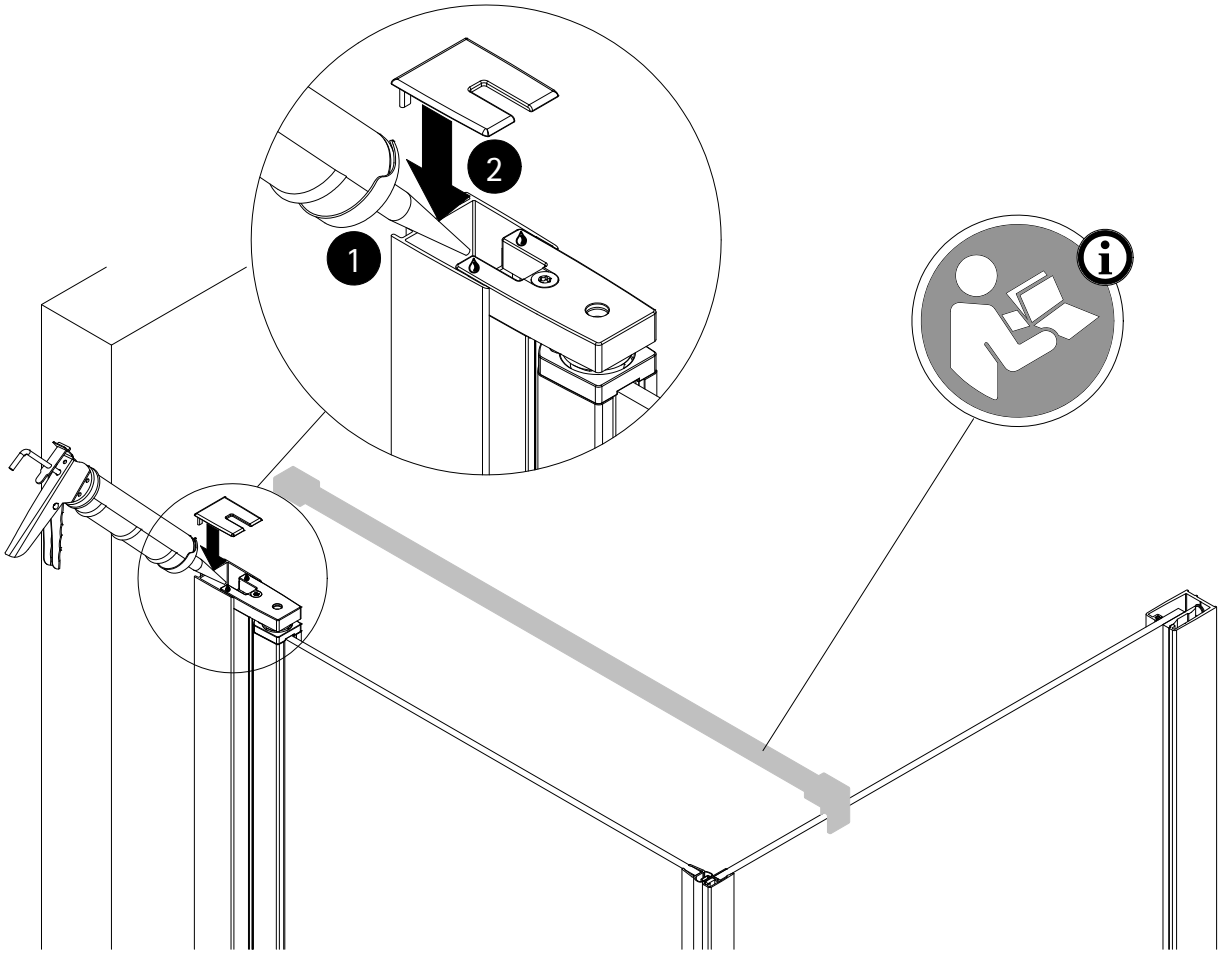

34

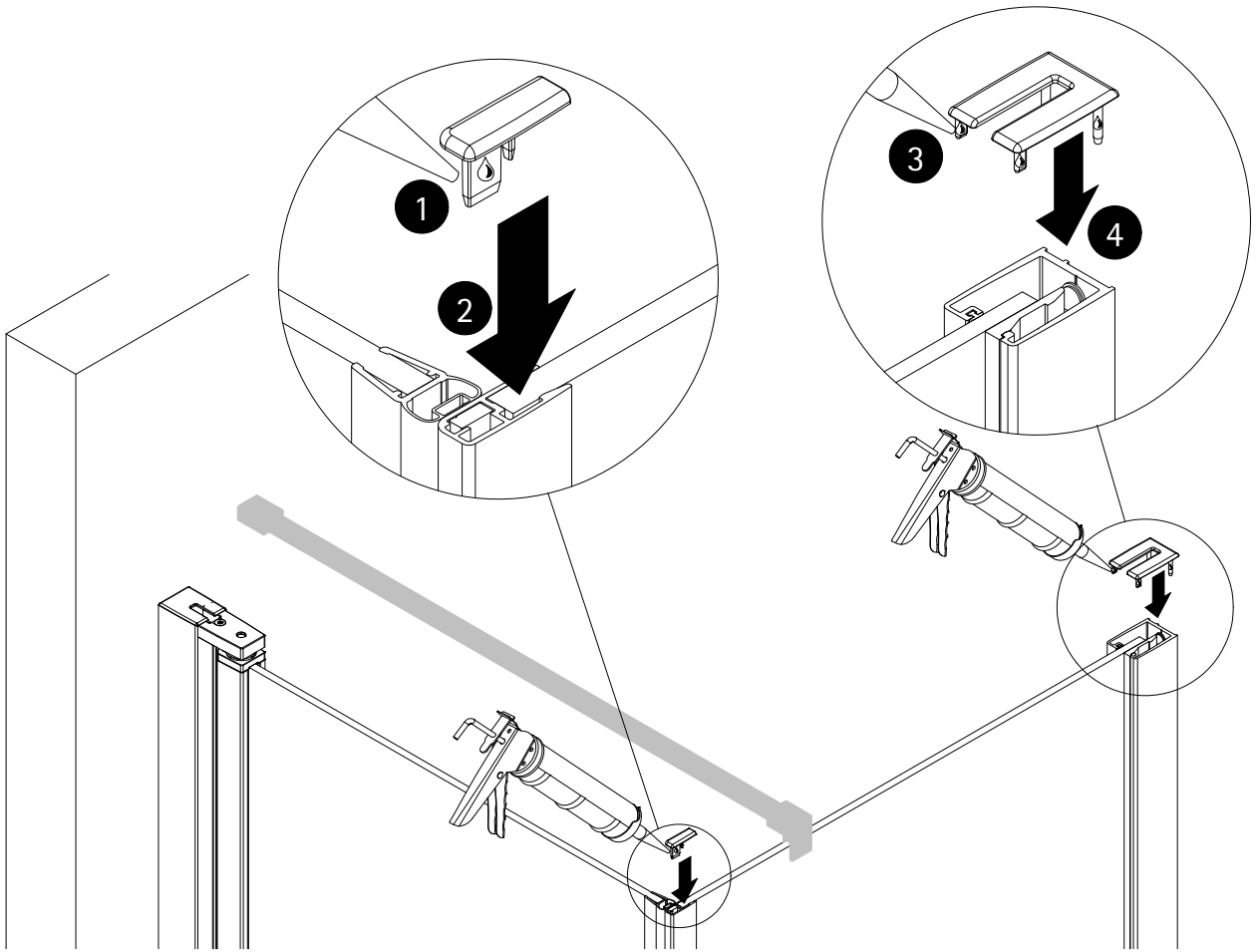

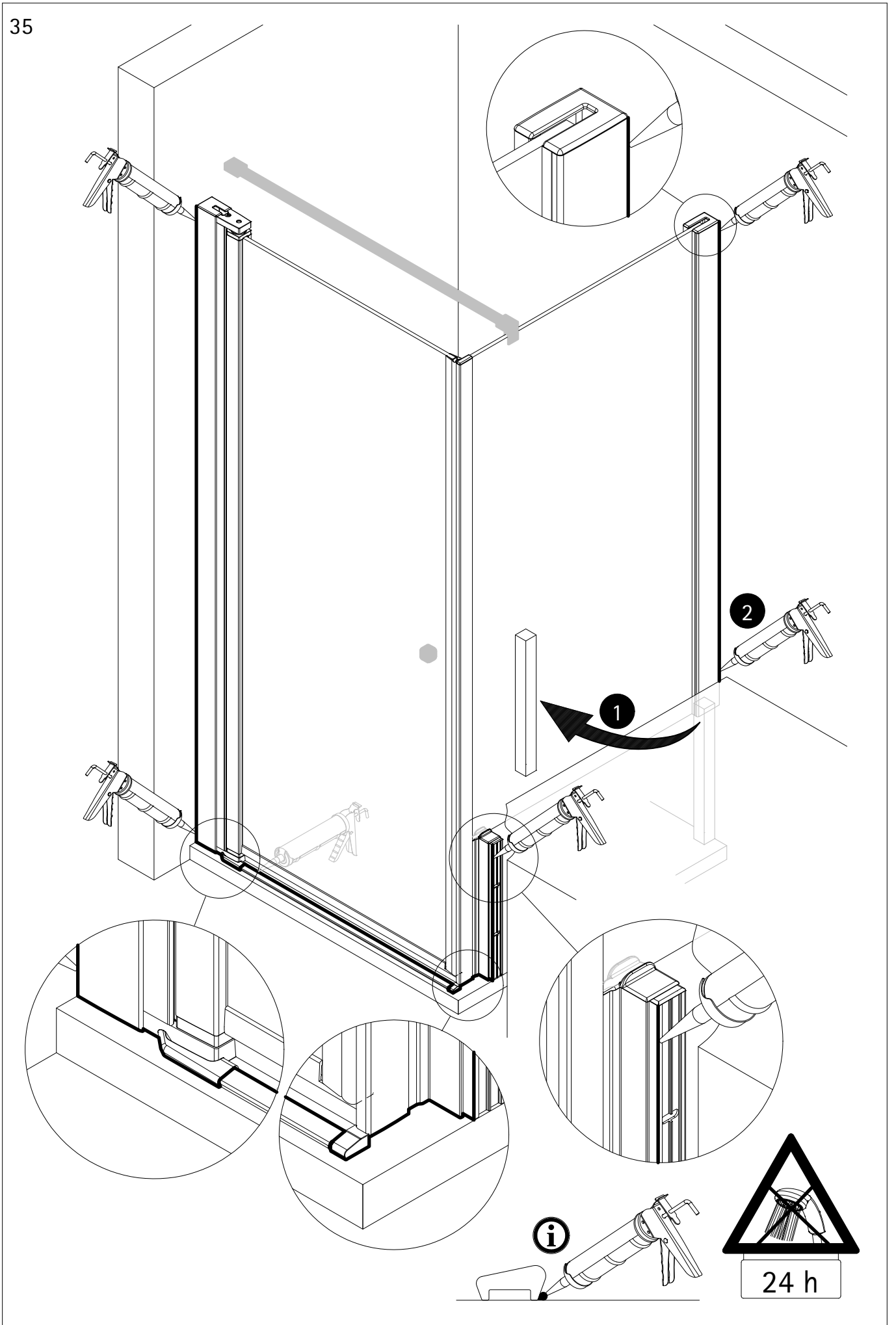

6940-8

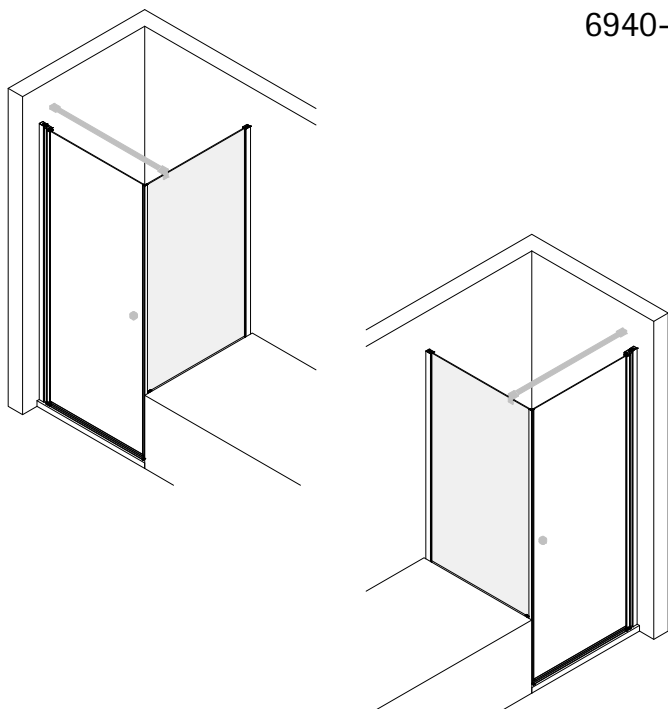

Technische Hilfe / technical help / l'aide technique / technologische ondersteuning
Ersatzteilbestellung / spare parts order
commande de pièces détachées / Bestelling van onderdelen:
Telefon 02631 / 8607-0



E-Mail: info@duschkabine.com



Dusch-Info
August-Horch-Straße 1
56566 Neuwied
Deutschland / Germany / Allemagne / Duitsland

